

## Automation of Orchid Soil pH Using IoT-Based Soil pH Sensor (SKJ-001)

**Putri Nur Hidayah Komaria, Alya Putri Yoanda, Diana Mauli Rahma, Jutira Ayu,  
Regi Tia Margareta, Assa'idah Assa'idah, Fitri Suryani Arsyad\***

*Department of Physics, Faculty of Mathematics and Natural Science, University of Sriwijaya,  
Sumatera Selatan 30128, Indonesia*

(Received September 06, 2025; revised October 04, 2025; accepted October 06, 2026; published online October 10, 2025)

The growth and development process of cymbidium orchids requires a soil pH of around 5.5–6.5. Otherwise, it will cause low nutrient absorption, resulting in yellow leaves and slow growth, while too high a pH can cause the plant's roots to die. Therefore, this study developed an IoT-based ESP32 soil pH automation design to maintain soil pH stability and reduce orchid growth and development failures due to unstable soil pH. The IoT-based ESP32 soil pH automation design allows remote monitoring of soil pH conditions via a smartphone that has downloaded the Blynk application. The soil pH automation design consists of an SKJ-001 soil pH sensor to measure soil pH, an HC-SR04 ultrasonic sensor to measure solution height, and a 5 VDC pump to circulate NaOH and HCl solutions to stabilize pH. This soil pH automation system has been tested on ten soil samples with an average accuracy of 98.606%, an average precision of 99.192%, and an average error of 0.581%. Based on these results, it can be concluded that the IoT-based ESP32 soil pH automation system is effective and reliable in maintaining soil pH stability, thereby supporting optimal growth and development of cymbidium orchids.

**Keywords:** *Blynk, ESP32, Internet of Things (IoT), Soil pH Automation, Soil pH Sensor.*



*This is an open access article under the [CC BY-NC](https://creativecommons.org/licenses/by-nc/4.0/) license.  
Copyright © 2025 by Author. Published by Physical Society of Indonesia*

### 1. INTRODUCTION

In the modern era of 4.0, technological advances continue to increase, especially in the development of the Internet of Things (IoT). IoT has enabled broad and intelligent connectivity between devices, opening new opportunities in various fields, including agriculture. The agricultural sector, which is traditionally managed manually, can benefit significantly from IoT-based solutions to increase efficiency, accuracy, and sustainability.

One of the important aspects in agriculture is soil pH control, which plays a key role in plant nutrient absorption. Until now, soil pH control is still largely conducted manually, making it difficult for farmers to know the exact nutritional needs of plants. If the soil pH is too low, plants tend to experience nutrient deficiency, resulting in yellow leaves, whereas if the pH is too high, plant roots can be damaged or even die (Rachmawati & Wardiyati, 2017). This condition illustrates the urgent need for modern technological solutions to maintain soil pH stability.

In particular, orchids are among the plants that require special attention to soil conditions. Indonesia is known to have around 5,000 species of orchids spread across its forests (Anggraeni, 2022). Among them, terrestrial orchids such as cymbidium are highly valued for their shape, beauty, and uniqueness. For cymbidium orchids, optimal growth and development require soil pH in the range of 5.5–6.5 (De & Singh, 2018). If the pH level falls outside this range, the orchids' growth can be disrupted, leading to poor quality and low productivity.

Several studies have attempted to address this problem by developing soil pH monitoring systems. For example, research at Brawijaya University detected soil nutrients using a TCS3200 sensor that identified soil color (Anwar et al., 2018). Meanwhile, researchers at Bengkulu University created a

\*Contact Author: [fitri\\_suryani@unsri.ac.id](mailto:fitri_suryani@unsri.ac.id)

digital soil pH design using Arduino Uno (Sari et al., 2021). Although these studies have contributed valuable insights, there is still room to improve accuracy, automation, and integration with IoT platforms.

Therefore, this study proposes the development of an IoT-based soil pH automation system using the SKJ-001 soil pH sensor based on polyaniline (PANI) connected to a NodeMCU ESP32 microcontroller. The system is designed to automatically maintain soil pH in the optimal range (5.5–6.5) by regulating NaOH and HCl solutions through a pump mechanism. Furthermore, the data are transmitted in real-time to the Blynk application, serial monitor, and LCD display. This research is expected to contribute to precision agriculture by providing an effective and reliable solution to support the optimal growth of cymbidium orchids.

## 2. SYSTEM DESIGN

### 2.1 Design of Soil pH Automation System

The soil pH automation system is divided into two parts, namely hardware design and software design. The hardware design for soil pH automation is shown in Figure 1.

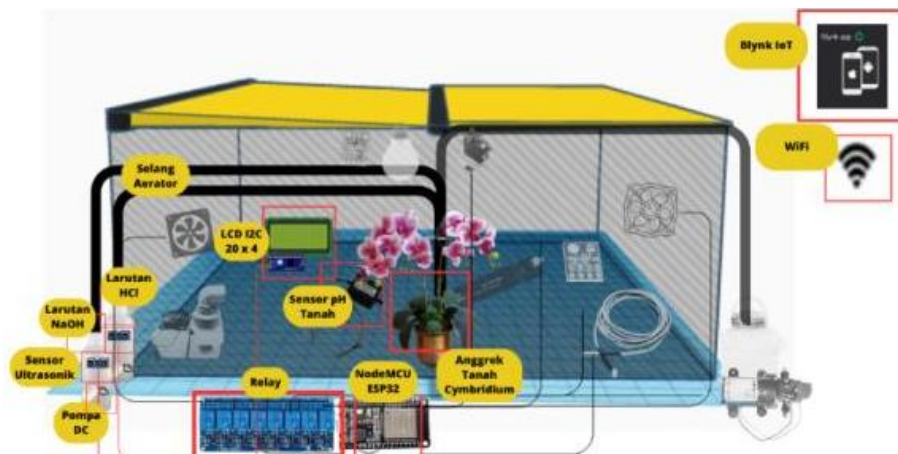

Figure 1. Design of soil pH automation hardware

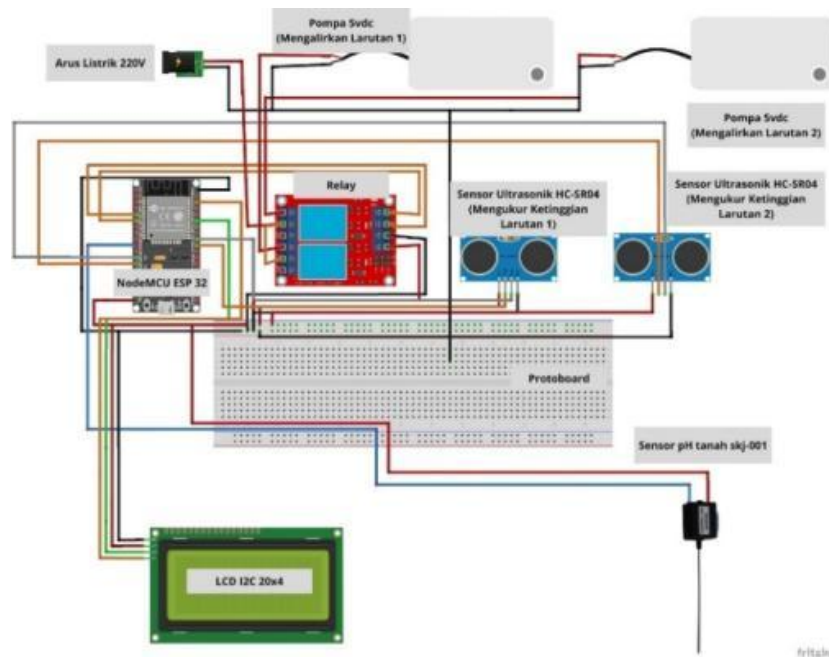

Figure 2. Schematic diagram of soil pH automation circuit

Figure 1 shows the design of soil pH automation hardware using the NodeMCU ESP32 microcontroller, which functions to read data from sensors and control electronic devices. The SKJ-001

The soil pH sensor is used to measure the soil pH of cymbidium orchids. If the soil pH of cymbidium orchids is < 5.5, the relay will supply electrical current so that the first 5VDC pump will release a solution to neutralize the soil pH. If the soil pH is > 6.5, the relay will supply electrical current so that the second 5 VDC pump will release a solution to neutralize the soil pH. If the soil pH is between 5.5 and 6.5, the relay will stop the electrical current, and both pumps will turn off. In the solution bottle, there is an ultrasonic sensor HC-SR04 to measure the solution level. Soil pH and solution height data will be displayed on the 20x4 I2C LCD, and the data will be stored in the Blynk application so it can be monitored remotely. The circuit was assembled by connecting the pins according to the illustration in Figure 2.

## 2.2 Tools and Materials

The tools and materials used for the soil pH automation circuit are:

### 2.2.1 Land

Soil is the medium in which plants grow. Plants absorb nutrients from the soil, so the fertility of plants depends on the nutrient content in the soil. Factors affecting plant growth and development include mineral and nutrient content, water availability, aeration, physical support, nutrient storage, soil microorganisms, and drainage capacity. One crucial aspect of this is the soil acidity level or soil pH (Purba et al., 2021). pH, or potential of hydrogen, is a scale that indicates the amount of hydrogen ions in a solution. Figure 3 illustrates the pH scale, where low pH is called "acidic" and high pH is called "basic." Moist soil tends to be acidic, while dry soil tends to be basic. The soil pH range is generally between 4 and 10 (Djule et al., 2018).

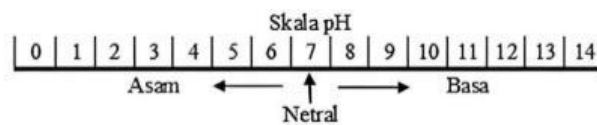

Figure 3. pH Scale

### 2.2.2 Soil pH Sensor

The soil pH sensor, shown in Figure 4, is used to measure the acidity or alkalinity level of the soil. This sensor is capable of measuring a pH range between 3.5 and 8 and operates on a 5-volt DC power supply. The sensor probe has a measurement range of 6 cm into the soil. The value generated by this soil pH sensor is an ADC value (Daniel et al., 2022). To determine the pH value from the ADC output, correlation calculations and linear regression calculations are required. The correlation formula is explained in equation (1) (Rozaq & Setyaningsih, 2018), the regression method formula is explained in equation (2), the formula for finding the value of b, which represents the regression coefficient (slope), is shown in equation (3), and the formula for finding the value of a, which is the intercept, is explained in equation (4) (Riyanto, 2014).

$$r = \frac{n(\sum xy) - (\sum x)(\sum y)}{\sqrt{n(\sum x^2) - (\sum x)^2} \sqrt{n(\sum y^2) - (\sum y)^2}} \tag{1}$$

With the following correlation coefficient (r) criteria:

- 0.00 – 0.199 : Very weak correlation
- 0.20 – 0.399 : Weak correlation
- 0.40 – 0.599 : Moderate correlation
- 0.60 – 0.799 : Strong correlation
- 0.80 – 1.000 : Very strong correlation (Kumar et al., 2015).

$$y = bx + a \tag{2}$$

$$b = \frac{\sum x_i y_i - n \bar{x} \bar{y}}{\sum x_i^2 - n \bar{x}^2} \tag{3}$$

$$a = \bar{y} - b\bar{x} \quad (4)$$

The working principle of a soil pH sensor is based on electrochemistry, where pH measurement depends on the level of hydrogen ions in the solution. When the soil comes into contact with the glass electrode and the reference electrode, electrons move and interact with non-metallic elements, producing electricity. The glass electrode attracts hydrogen ions, while the reference electrode acts as a buffer and comparator. The voltage difference between the two is converted into a pH value. This sensor is made from active materials such as silicon dioxide, silicon nitride, and aluminum oxide for the glass electrode, as well as polymers like polyaniline and conductive materials like Ag paste for the reference electrode (Kumar et al., 2015).

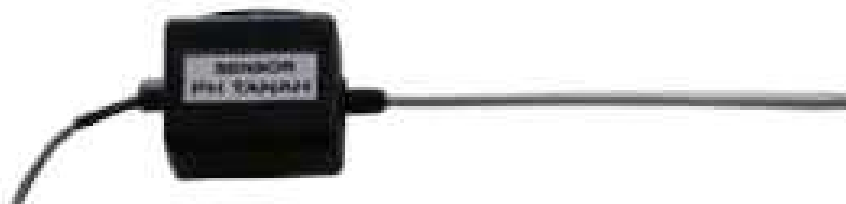

**Figure 4.** Soil pH sensor SKJ-001

### 2.2.3 HC-SR04 Ultrasonic Sensor

The HC-SR04 ultrasonic sensor, shown in Figure 5, uses the principle of sound wave reflection to detect the presence of objects. This sensor operates with sound waves between 20 KHz and 2 MHz. The HC-SR04 ultrasonic sensor is made of piezoelectric crystal material (Arasada, 2017). The piezoelectric crystal materials used include lead zirconium titanate (PbZrTiO<sub>3</sub>) and barium titanate (BaTiO<sub>3</sub>) (Hananto et al., 2011). The structure of the ultrasonic sensor involves a piezoelectric crystal connected to a mechanical anchor and mounted on a vibrating diaphragm. When alternating voltage is applied to the crystal, its structure undergoes contraction or expansion, enabling the sensor to function. When ultrasonic waves are emitted, if there is an object in front of them, the waves will be reflected and received back by the receiving sensor unit.

The working principle of the HC-SR04 ultrasonic sensor is to send ultrasonic waves toward an object and measure the time it takes for the waves to be reflected back. The object's distance is calculated based on the time it takes for the wave to bounce back, with a measurement range between 3cm and 3m. The ultrasonic sensor requires 2 I/O pins to interact with the microcontroller: the trigger pin and the echo pin. To activate the sensor and measure the distance of an object to the sensor, the microcontroller sends a positive pulse through the trigger pin and then measures the duration of the positive pulse returned through the echo pin (Arasada, 2017). The HC-SR04 ultrasonic sensor is used to measure the height of the solution.



**Figure 5.** HC-SR04 Ultrasonic Sensor

### 2.2.4 NodeMCU ESP32

The NodeMCU ESP32 microcontroller is a microcomputer chip component in the form of an IC developed by Espressif Systems from the ESP8266, which has a Wi-Fi module integrated into the processor chip, making it very useful in the development of Internet of Things (IoT) applications (Widyatmika et al., 2021). The NodeMCU ESP32 functions as a device that reads measurement data, sends it to the Blynk application, and controls electronic devices. The pin layout can be seen in Figure 6.

### 2.2.5 Arduino IDE

The Arduino IDE is an application used to create and manage microcontroller programs. The Arduino IDE uses the C++ language that has been simplified using libraries (Arifin et al., 2016). This application is used to upload programs to the NodeMCU ESP32 microcontroller.

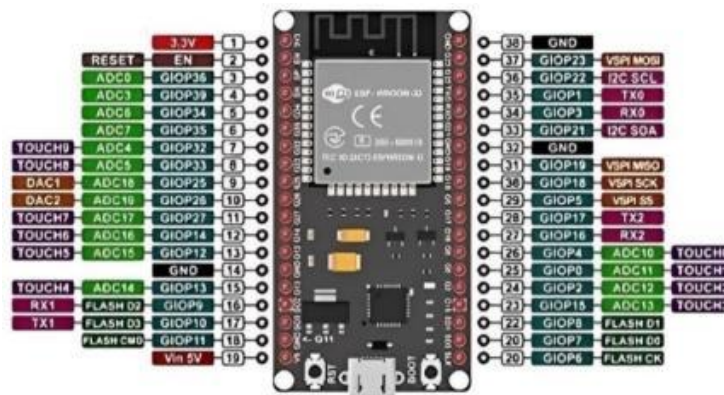

Figure 6. Pin-pin NodeMCU ESP32

### 2.2.6 Liquid Crystal Display (LCD)

A Liquid Crystal Display (LCD) is an electronic device that uses liquid crystal segments that can change according to the applied voltage. Figure 7 shows an LCD that is more effective to use because it is lightweight, consumes less energy, and is not susceptible to heat (Warjono et al., 2017). The output displayed by the LCD is the pH value and the height of the NaOH and HCl solutions.



Figure 7. Liquid Crystal Display

### 2.2.7 Relay

A relay is an electromechanical component that functions as an electrically operated switch. Figure 8 shows a relay that uses the principle of electromagnetic force (Syam, 2013) to control the flow of electricity entering the solution pump, allowing the pump to turn on or off.



Figure 8. Relay

### 2.2.8 5 Volt DC Pump

A 5 Volt DC water pump is a device used to move water from a low-pressure area to a higher-pressure area. The water pump operates using a DC motor and works with a DC current voltage of 5 V (Ulum et al., 2022). The physical appearance of the DC pump is shown in Figure 9, which has a negative pole (-) and a positive pole (+). This DC water pump is for circulating the solution to cymbidium orchid plants.



**Figure 9.** 5 Volt DC Pump

### 2.2.9 Internet of Things (IoT)

The Internet of Things (IoT) is a technology that creates widespread and intelligent connectivity between devices, allowing them to interact with each other, collect data, perform analysis, monitor and control, and take actions automatically based on the information received (Yudhanto & Aziz, 2019). With the existence of IoT technology, the process of monitoring soil pH and solution level measurement data is simplified, and it becomes easier to control pump performance remotely through the Blynk application.

### 2.2.10 Blynk

Blynk is a platform used to control Arduino microcontrollers, ESP8266, ESP32, Raspberry Pi, and other microcontroller devices over the internet. The Blynk application is not tied to specific components or chips, but the device used can access WiFi to communicate with the hardware being used (Syukhron et al., 2021). With Blynk, the data measured in the soil pH automation system can be monitored and stored in real time.



**Figure 10.** Cymbidium Orchids

### 2.2.11 Orchid Plants

Orchid plants are one of the ornamental plants with a greater variety of species compared to other ornamental plants. This orchid plant can be found in various temperature conditions, depending

on its type, and is generally distributed in tropical and subtropical regions. Worldwide, the number of orchid species is estimated to be between 17,000 and 35,000 with 5,000 of them found in Indonesia, particularly in Papua and Kalimantan (Anggraeni, 2022). One example of an orchid with size variations, long leaves, beautiful flowers, and an upright stem forming a pseudobulb and fleshy roots covered by velamen (Garvita & Damhuri, 2022) is the cymbidium orchid, as shown in Figure 10. Factors such as soil pH, light, temperature, humidity, and growing medium affect the growth and development of orchids. The optimal soil pH for cymbidium orchids is 5.5-6.5 (De & Singh, 2018). If the soil pH is too low (<5.5), it can cause difficulty in nutrient absorption by the plants, while if it is too high (>6.5), it can inhibit the growth of cymbidium orchids.

### 2.3 Workflow of the Soil pH Automation System

The workflow of the soil pH automation system requires WiFi and the Arduino IDE application to program the microcontroller, and Blynk for remote and real-time monitoring.

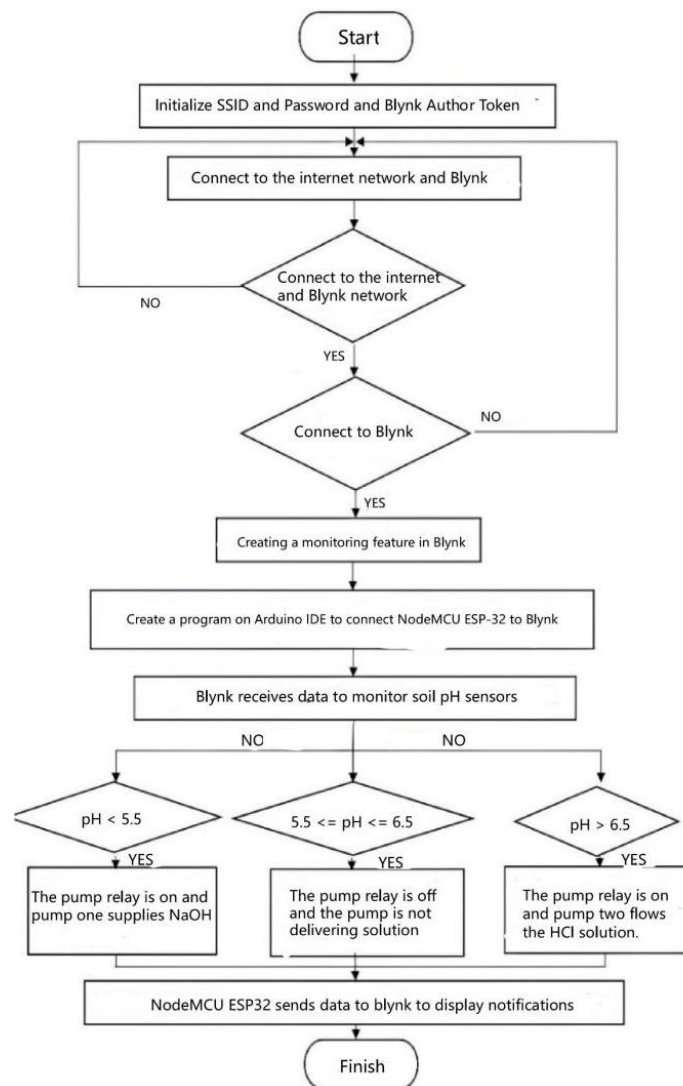

**Figure 11.** Workflow of the Soil pH Automation System

The workflow of the soil pH automation system that has been created is shown in Figure 11. The first step is to initialize the WiFi SSID and password, as well as the Blynk author token obtained from the Blynk website template. After that, connect to the internet and Blynk. If connected, proceed to create monitoring features in Blynk. If not connected, reconnect to the internet and Blynk. After creating the Blynk application features, the next step is to create a program in the Arduino IDE to connect the

NodeMCU ESP-32 to Blynk. After the program runs, Blynk receives data to monitor the soil pH sensor. If the  $pH < 5.5$ , the pump relay turns on and pump one flows the solution; if the  $pH > 6.5$ , the pump relay turns on and pump two flows the solution. If the pH is between 5.5 and 6.5, the pump relay turns off and the pump does not flow the solution. Once the soil pH measurement data meets one of the conditions, the NodeMCU ESP32 will send the data to Blynk to display a notification.

### 2.4 Blynk Monitoring Feature Design

In this soil pH automation system, Blynk is used as a monitoring application with the same WiFi communication between the NodeMCU ESP32 microcontroller and the Blynk author token. There are four databases in this system: the soil pH measurement database, the ADC pH database, the NaOH level database, and the HCl level database. The four databases were created in the datastream menu of the Blynk website. These datastreams use the same virtual pins as the commands that will be programmed in the Arduino IDE. To monitor the system's measurements, a web dashboard was first created by selecting the label and chart features, resulting in the dashboard display on the Blynk website. Figure 12 shows real-time monitoring of the four measurement databases. In addition to website monitoring, monitoring was also created in the Blynk application, as shown in Figure 13, for easier real-time monitoring of the soil pH automation system.

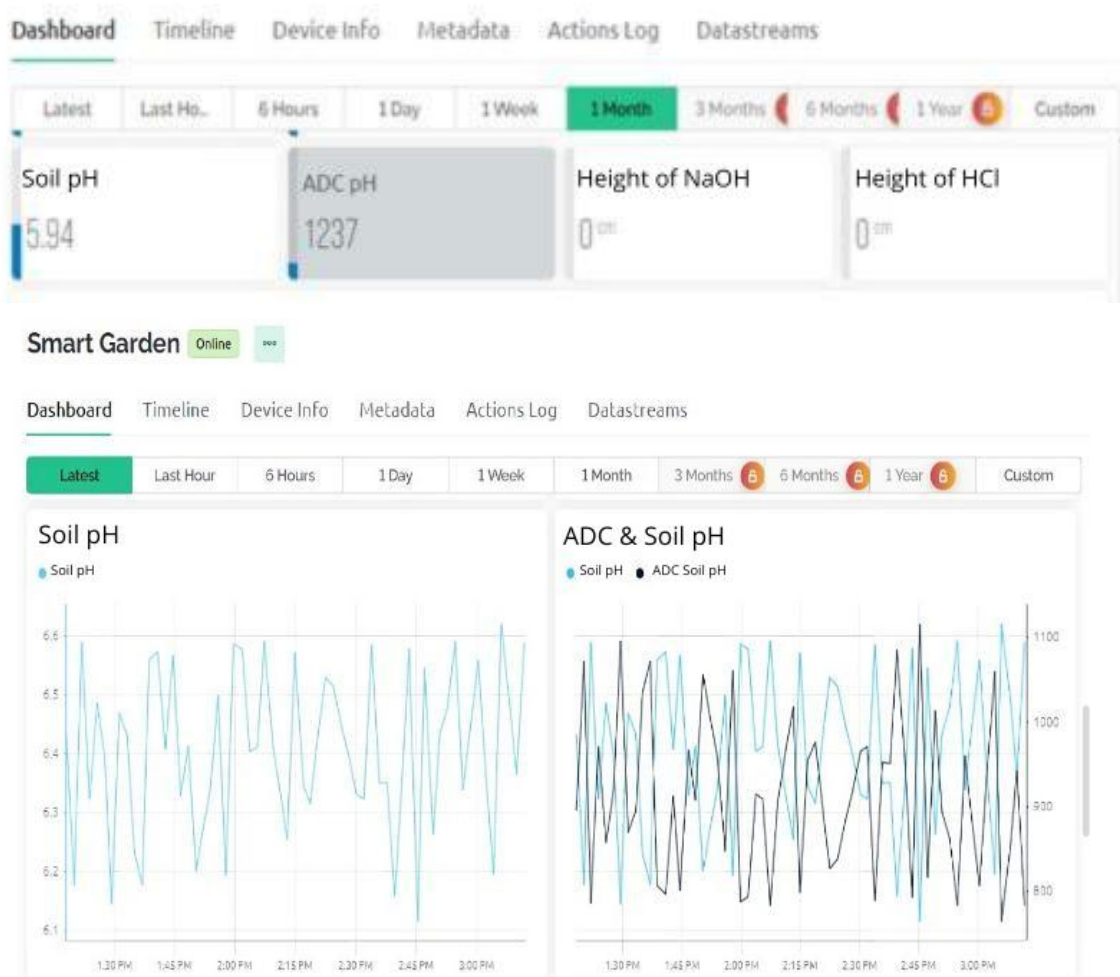

Figure 12. Monitoring Display on the Blynk Website

Besides creating a monitoring feature, the Blynk application can create a notification feature for the performance of the solution pump made through the Blynk website by selecting the "events &

notifications" menu. Therefore, if the pump is working, a notification will appear on the Blynk website as shown in Figure 14 (a) and a notification on the Blynk application as shown in Figure 14 (b). With the email address registered in Blynk, all smartphones connected to that email and logged into Blynk using that email address can monitor this soil pH automation system.

## 2.5 Integration of the Soil pH Automation System Circuit

Before starting the assembly of the soil pH automation system, inspect each component to avoid errors and problems with any of them. After ensuring that all devices are functioning properly, proceed with the process of assembling the soil pH automation system. For the integration of the soil pH automation system circuit according to the pins in Table 1. First step, connect the NodeMCU ESP32 to the soil pH sensor and DMS using jumper wires. In this circuit, the red jumper is connected to the 3V3 pin, the yellow jumper is connected to pin 34, the green jumper is connected to pin 13, and the brown and white jumpers are connected to ground. Next, connect the HC-SR04 ultrasonic sensor using the 6 pins of the NodeMCU ESP32.

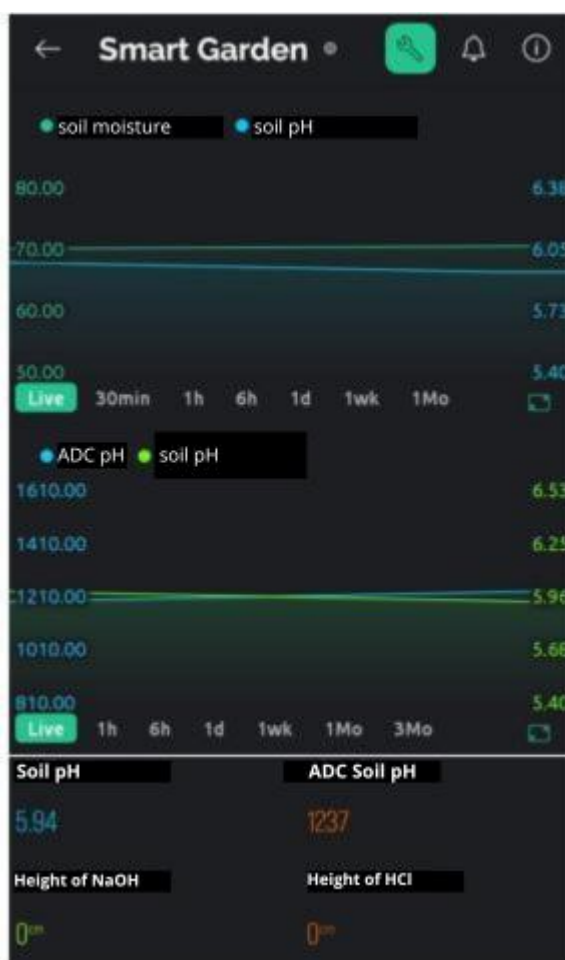

Figure 13. Monitoring Display in the Blynk Application

After the sensor is connected, the relay is connected using 4 pins of the NodeMCU ESP32, and the 20x4 I2C LCD is connected with 4 pins of the NodeMCU ESP32. The 5 Volt DC pump is connected to the relay and the adapter. Besides combining circuits, the soil pH automation system creates an incubator-shaped hardware made of acrylic, which is block-shaped. The acrylic size is 100 cm long, 80 cm wide, and 80 cm high, with an acrylic thickness of 3 mm. The base is a 5 mm plywood board, and the sliding roof is made of 3 mm plywood.

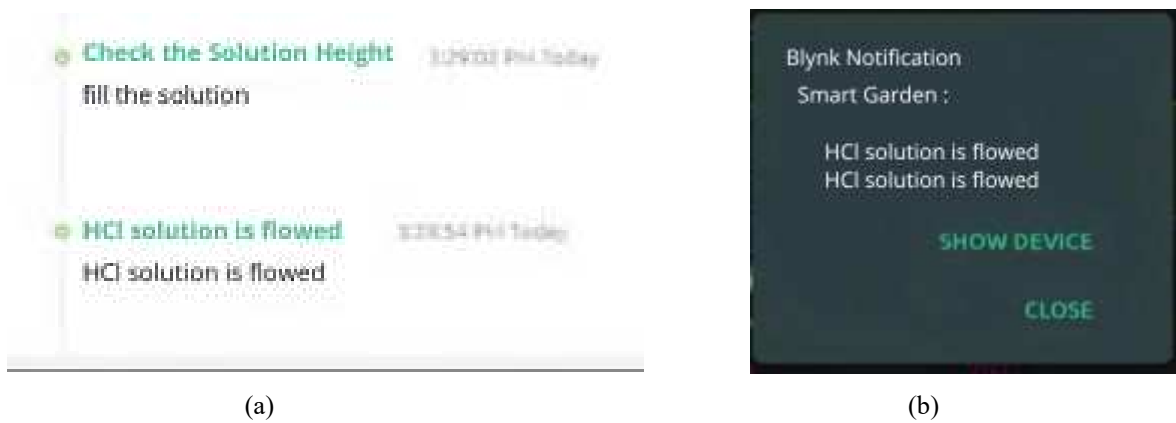

Figure 14. (a) Notification Display on the Blynk Website (b) Notification Display on the Blynk Application

Table 1. Pin used in the circuit

NodeMCU ESP32	SKJ-001 Soil pH Sensor & DMS	HC-SR04 Ultrasonic Sensor	Relay	LCD I2C 20 x 4
Vin (5 Volt) 3V3	- Red jumper	- VCC	VCC	VCC
Ground	Brown & white jumper	Ground	Ground	Ground
D5	-	-	IN1	-
D12	-	Trig_1	-	-
D13	Green jumper	-	-	-
D14	-	Echo_1	-	-
D18	-	-	IN2	-
D21	-	-	-	SDA
D22	-	-	-	SCL
D25	-	Trig_2	-	-
D26	-	Echo_2	-	-
D34	Yellow jumper	-	-	-

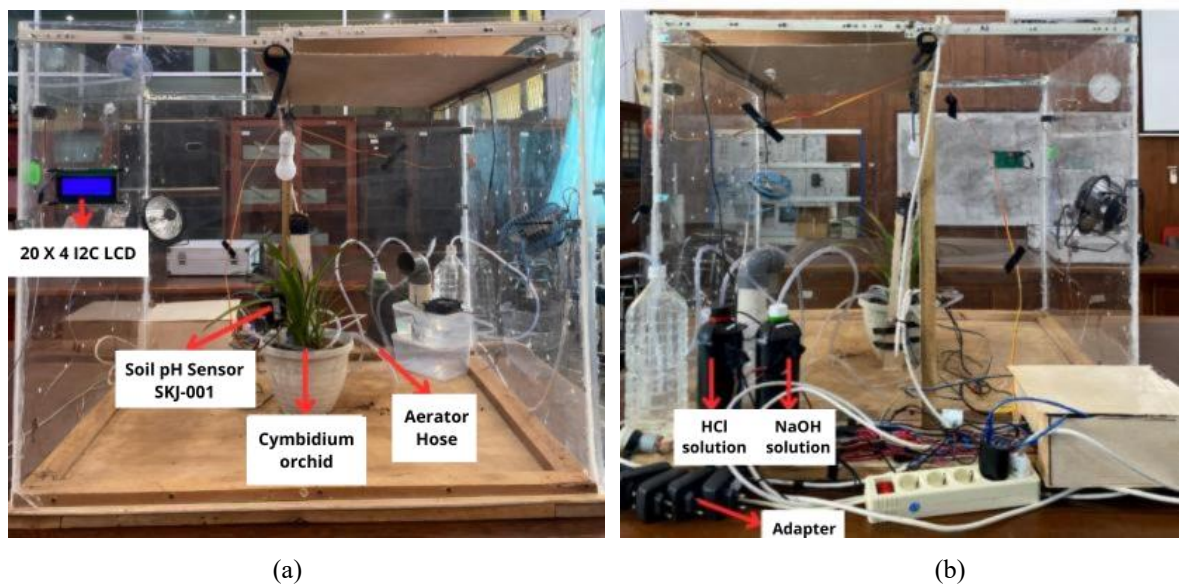

Figure 15. (a) Front View of Soil pH Automation Tool Design Results (b) Rear View of Soil pH Automation Tool Design Results.

### 3. RESULTS AND DISCUSSION

The front view of the soil pH automation system is shown in Figure 15 (a), and the design results of the soil pH automation tool from the rear view are shown in Figure 15 (b). The soil pH automation system includes a SKJ-001 soil pH sensor, an HC-SR04 ultrasonic sensor, a 20 x 4 I2C LCD, an aerator hose, NaOH solution, HCl solution, an adapter, and a cymbidium orchid. Before this soil pH automation system can be used, testing is required, starting with the calibration process of the soil pH sensor, testing the performance of the solution pump, testing the WiFi communication range, testing the characteristics of the device, and data validation testing.

#### 3.1 Calibration of Soil pH Sensor SKJ-001

The calibration of the SKJ-001 soil pH sensor for measuring pH was performed by comparing the measurement results from the SKJ-001 soil pH sensor, which produces ADC values, with the comparison tool, the Soil pH – Moisture Meter VT-05, which produces pH values. This was done to obtain an equation for converting ADC values to pH values with small errors. Measurements were taken using ten soil samples with pH values of 4.7, 5.2, 5.4, 5.9, 6, 6.1, 6.4, 6.5, 6.6, and 6.7. The calibration data for the SKJ-001 soil pH sensor can be seen in Table 2.

**Table 2.** Testing the ADC Value of the SKJ-001 Soil pH Sensor Against the pH Value of the Reference Instrument

Number	The pH value of the Soil pH-Moisture Meter VT-05	The pH value of the Soil pH-Moisture Meter VT-05
1.	4.7	2097
2.	5.2	1750
3.	5.4	1611
4.	5.9	1264
5.	6	1195
6.	6.1	1125
7.	6.4	917
8.	6.5	848
9.	6.6	778
10.	6.7	709

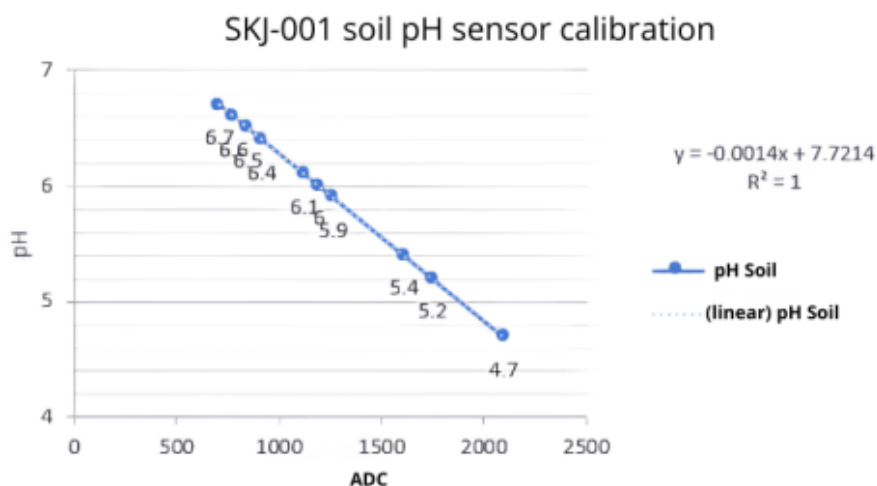

**Figure 16.** Calibration Graph for Soil pH Sensor SKJ-001

Calibration of the SKJ-001 soil pH sensor against the VT-05 soil pH – moisture meter reference instrument yielded a correlation (r) of -1, indicating that the direction of the linearity line slopes to the left, and an R2 value of 1, meaning the correlation between the ADC and the reference instrument is

very strong and can be used as a measuring tool. This correlation is illustrated by the calibration graph of the SKJ-001 soil pH sensor in Figure 16. To obtain the formula for converting ADC values to pH values using linear regression calculation, the equation  $y = -0.00144x + 7.721359$  was obtained. After obtaining the equation for converting ADC values to pH values, it is necessary to test the conversion equation with the actual instrument.

**Table 3.** Equation Testing with a Comparison Tool

Number	Soil pH Sensor SKJ-001	Soil pH – Moisture Meter VT-05	Error (%)
1.	4.701	4.7	0.1
2.	5.207	5.2	0.7
3.	5.403	5.4	0.3
4.	5.905	5.9	0.5
5.	5.998	6	-0.2
6.	6.102	6.1	0.2
7.	6.397	6.4	-0.3
8.	6.503	6.5	0.3
9.	6.595	6.6	-0.5
10.	6.702	6.7	0.2
average error (%)			0.13

Table 3 explains the equation testing using the soil pH – moisture meter VT-05 as a comparison tool, which resulted in an error of 0.13%, and the pH value is inversely proportional to the ADC value.

### 3.2 Testing the Value of the Soil pH Sensor Against Pump Performance

Testing the SKJ-001 soil pH sensor value against pump performance was conducted to determine whether the NaOH pump successfully delivered the solution when the soil pH was less than 5.5, and whether the HCl pump successfully delivered the solution when the soil pH was greater than 6.5. The testing was performed using 10 soil samples with pH values of 5.4, 5.9, 6, 6.1, 6.2, 6.3, 6.4, 6.5, 6.6, and 6.7. The following is Table 4 showing the testing of the SKJ-001 soil pH sensor value against pump performance.

**Table 4.** Testing the Value of the Soil pH Sensor SKJ-001 Against

Number	Date	Time	Soil pH value	Pump Status	Description
1.	23/12/2023	10:13:08	5.923	Off	Both solution pumps were successfully shut down.
2.	23/12/2023	14:40:46	5.427	On	The NaOH solution pump was successfully started.
3.	24/12/2023	15:33:30	6.622	On	The HCl solution pump was successfully started.
4.	24/12/2023	15:36:12	6.553	On	The HCl solution pump was successfully started.
5.	24/12/2023	15:41:44	6.702	On	The HCl solution pump was successfully started.
6.	24/12/2023	15:42:19	6.126	Off	Both solution pumps were successfully shut down.
7.	24/12/2023	15:44:08	6.024	Off	Both solution pumps were successfully shut down.
8.	24/12/2023	15:46:13	6.201	Off	Both solution pumps were successfully shut down.
9.	24/12/2023	15:50:40	6.361	Off	Both solution pumps were successfully shut down.
10.	25/12/2023	10:29:37	6.453	Off	Both solution pumps were successfully shut down.

Table 4 explains the testing data of the SKJ-001 soil pH sensor against pump performance. The ten different samples produced different pump performances. When the soil samples have pH values of 5.923, 6.126, 6.024, 6.201, 6.361, and 6.453, the solution pumps are not functioning because the pH values of these six samples meet the optimal pH requirements for Cymbidium orchids, which is between 5.5 and 6.5 (De & Singh, 2018). When the soil sample has a pH value of 5.427, the NaOH solution pump successfully delivers the NaOH solution, while the HCl pump does not deliver the solution because the soil pH is less than 5.5, meaning the soil is too acidic, causing the leaves to turn yellow and nutrient absorption to be low (Rachmawati & Wardiyati, 2017), so it needs to be neutralized with NaOH solution. On the other hand, when the soil samples have pH values of 6.622, 6.553, and 6.702, the HCl solution pump successfully delivers the HCl solution, while the NaOH pump does not deliver the solution because the soil pH is greater than 6.5, meaning the soil is too alkaline, causing the roots to die (Rachmawati & Wardiyati, 2017), so it needs to be neutralized with HCl solution. The pump's performance against the SKJ-001 soil pH sensor value testing is recorded in the Blynk application.

### 3.3 Testing the WiFi Communication Distance of the NodeMCU ESP32

To test the communication range of the NodeMCU ESP32 WiFi, an experiment was conducted to determine the delay in sending data to the serial monitor and Blynk in response to readings from the SKJ-001 soil pH sensor. This test was conducted in an electronics laboratory with a range of 5 meters and stable signal conditions from a smartphone hotspot. The purpose is to compare the data transmission time on the serial monitor and Blynk. The results of the WiFi communication distance test for the NodeMCU ESP32 can be seen in Table 5.

**Table 5.** Data of WiFi Communication Distance Test Results for NodeMCU ESP32

Number	WiFi Distance from Device (m)	Data Sending Time to Blynk	Time to Send Data to Serial Monitor	Delay (s)
1.	0	09 : 25 : 59	09 : 26 : 01	2
2.	5	09 : 29 : 46	09 : 29 : 45	2
3.	10	09 : 33 : 33	09 : 33 : 35	2
4.	15	09 : 37 : 20	09 : 37 : 22	2
5.	20	-	-	-
6.	50	-	-	-

Data transmission of the soil pH sensor SKJ-001 measurement results follows the program instructions already uploaded from the Arduino-IDE application to the NodeMCU ESP32 microcontroller. The command to send data to Blynk was added before the serial monitor data sending command line. Therefore, the data transmission time to Blynk is faster than the data transmission time on the serial monitor. Based on the test results, the maximum WiFi communication distance with the NodeMCU ESP32 is 15 meters using a smartphone hotspot. At a distance of 0 – 15 meters, the delay or the ratio of serial monitor transmission time to Blynk is 2 seconds, while at a distance of 20 – 50 meters, data transmission fails because the smartphone hotspot is too far. The data transmission time to Blynk at distances of 10 and 15 meters is recorded on the application web dashboard and website, but the data is not displayed in CSV format. Based on these tests, it can be concluded that data transmission still has the same delay when the soil pH automation system is within the range of a stable WiFi signal and data transmission is in accordance with the program that has been run on the Arduino IDE application. If the signal is unstable, there will be delays in the data transmission process. The weaker the WiFi signal connected to the soil pH automation tool, the greater the likelihood of data transmission delays.

### 3.4 Testing of Equipment Characteristics

The purpose of testing the soil pH automation system tool is to determine the accuracy and precision levels of the soil pH and solution height measuring instruments. Test the accuracy of the instrument by comparing the pH values from the SKJ-001 sensor with the VT-05 soil pH moisture meter

as a reference instrument. To determine the accuracy of the equipment used, data was collected from the equipment 10 times in the electronics laboratory. Testing the characteristics of the soil pH automation system tool was conducted by calculating the data obtained to determine the average value, bias, standard deviation, accuracy, precision, and error. This aimed to determine whether the soil pH automation design met the applicable instrument suitability parameters. The test data for the characteristics of the SKJ-001 soil pH sensor are presented in Table 6.

Based on Table 6, the testing of the characteristics of the SKJ-001 soil pH sensor with the comparison tool, the VT-05 soil pH moisture meter, yielded an average bias value of 0.036, an average standard deviation value of 0.016, an average accuracy value of 98.606%, an average precision of 99.192%, and an average error of 0.581%. It can be seen that the smaller the values of bias, standard deviation, and error, the greater the values of accuracy and precision. Based on the above characteristic test results, it can be concluded that the soil pH automation system tool meets the instrument measurement validity standards with a standard deviation value less than 2%, accuracy and precision greater than 95%, and error less than 5% (Riyanto, 2014).

**Table 6.** Results of Soil pH Sensor SKJ-001 Characteristic Testing

Number	Soil pH Moisture Meter VT-05	Average pH of pH Sensor	Biase d	Standard deviation	Accuracy (%)	Precision (%)	Error (%)
1	5.4	5.405	0.005	0.023	98.624	98.714	0.089
2	5.9	5.957	0.057	0.015	98.274	99.248	0.966
3	6	6.056	0.056	0.033	97.422	98.368	0.932
4	6.1	6.143	0.043	0.014	98.617	99.322	0.700
5	6.2	6.230	0.030	0.021	98.512	99.004	0.487
6	6.3	6.347	0.047	0.010	98.757	99.513	0.752
7	6.4	6.438	0.038	0.024	98.301	98.905	0.597
8	6.5	6.552	0.052	0.012	98.643	99.445	0.797
9	6.6	6.624	0.024	0.009	99.242	99.599	0.356
10	6.7	6.709	0.009	0.004	99.670	99.800	0.130
<b>Average</b>			0.036	0.016	98.606	99.192	0.581

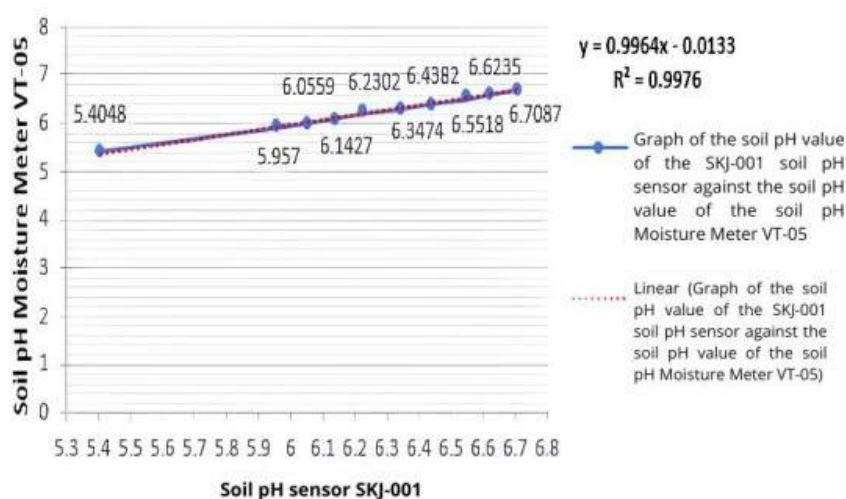

**Figure 17.** Graph of Soil pH Value from Soil pH Sensor SKJ-001 vs. Soil pH Value from Soil pH Moisture Meter VT-05

The characteristic test of the SKJ-001 soil pH sensor meets good instrument validation standards, partly because the SKJ-001 soil pH sensor is made of active materials such as silicon dioxide, silicon nitride, and aluminum oxide for the glass electrode, as well as the conductive polymer material

polyaniline (PANI) when exposed to pH changes, and uses silver (Ag) and silver chloride (AgCl) for the reference electrode, which keeps the potential stable for the electrochemistry of the pH electrode.

In Figure 17, the graph of the results of the SKJ-001 soil pH sensor characteristic shows a correlation value of 0.9976, which is close to 1. This means that the correlation between the soil pH value from the SKJ-001 soil pH sensor and the VT-05 soil pH moisture meter is very strong. The linear regression equation obtained was  $y = 0.9964x - 0.0133$ .

### 3.5 Data Validation Testing on Blynk, Serial Monitor, and LCD

Data validation testing was conducted on Blynk, the serial monitor, and the LCD to ensure that the data read on Blynk, the serial monitor, and the LCD had the same or different values. If the output data displayed on Blynk, the serial monitor, and the LCD were the same, then the program in the Arduino IDE and the data streams on Blynk could be considered successful. The results of the data validation testing on Blynk, the serial monitor, and the LCD can be found in Table 7.

Tabel 7. Results of Data Validation Testing on Blynk, Serial Monitor, and LCD

No	Blynk			Serial Monitor			LCD			Information
	pH	NaOH (cm)	HCl (cm)	pH	NaOH (cm)	HCl (cm)	pH	NaOH (cm)	HCl (cm)	
1	6.261	0	11	6.3	0	11	6.26	0	11	Valid
2	6.284	0	11	6.3	0	11	6.28	0	11	Valid
3	6.338	40	11	6.3	40	11	6.34	40	11	Valid
4	6.559	40	11	6.6	40	11	6.56	40	11	Valid
5	6.433	40	11	6.4	40	11	6.43	40	11	Valid

	A	B	C	D	E
1	Time	Soil pH	NaOH	HCl	ADC pH
11721	1/4/2024 9:04			11	
11722	1/4/2024 9:04		40		
11723	1/4/2024 9:04	6.438			891
11724	1/4/2024 9:03			11	
11725	1/4/2024 9:03	6.372	40		
11726	1/4/2024 9:02				937
11727	1/4/2024 9:01			11	
11728	1/4/2024 9:01		40		
11729	1/4/2024 9:01	6.433			895
11730	1/4/2024 8:59			11	
11731	1/4/2024 8:59		40		
11732	1/4/2024 8:59	6.559			807
11733	1/4/2024 8:57			11	
11734	1/4/2024 8:57		40		
11735	1/4/2024 8:57	6.338			961
11736	1/4/2024 8:55			11	
11737	1/4/2024 8:55		0		
11738	1/4/2024 8:55	6.284			998
11739	1/4/2024 8:53			11	
11740	1/4/2024 8:53		0		
11741	1/4/2024 8:53	6.261			1014

Figure 18. Blynk Report Display Results

Based on Tabel 7, the data displayed on Blynk, the serial monitor, and the LCD have the same values for NaOH and HCl data. This indicates that the program running on the NodeMCU ESP32

microcontroller through the Arduino IDE application is functioning correctly and can send data to Blynk with accurate and real-time data. However, there are differences in the rounding of pH data among the three platforms. In the serial monitor with two significant figures, the pH data on the LCD is rounded to 3 significant figures, and the Blynk application has a rounding value of 4 significant figures.

In Figure 18, the data from the data validation test results is recorded on Blynk and sent to the Blynk report, which can be downloaded in CSV format. The recorded data has four significant figures for soil pH measurement because the Blynk datastreams were created using the double data type. However, in the Blynk report display, the NaOH and HCl levels in the program creation process and Blynk datastreams use the integer data type.

```
08 : 53 : 38.762 → ADC=1014 pH=6.3  
08 : 53 : 39.836 → Height of NaOH : 0 cm  
08 : 53 : 39.386 → Solution Still Sufficient  
08 : 53 : 40.842 → Height of HCl : 11 cm  
08 : 53 : 40.842 → Solution Still Sufficient
```

**Figure 19.** Serial Monitor Output

In Figure 19, the data from the data validation test displayed on the serial monitor has two significant figures because the data type being run in the Arduino IDE uses the float data type, resulting in the pH value displayed having two significant figures.



**Figure 20.** LCD Display Results

In Figure 20, the data from the soil pH automation design's hardware, which is displayed on the LCD, can be viewed offline. The LCD display has three significant figures because the data type running in the Arduino IDE uses the float data type.

#### 4. CONCLUSION

A soil pH automation system for orchid plants has been designed using the SKJ-001 soil pH sensor, the HC-SR04 ultrasonic sensor, a 5-volt pump, and a relay, utilizing the NodeMCU ESP32 microcontroller. The average accuracy value obtained is 98.606%, the average precision value is 99.176%, and the average error is 0.581%. Based on the soil pH measurement data obtained using the SKJ-001 sensor, processed by programming through the Arduino IDE and Blynk, and compared to the VT-05 soil pH moisture meter, the instrument meets the eligibility standards with an error of less than

5%. The measurement data can be downloaded in CSV format through Blynk and processed using Excel. The operation of the soil pH automation system can be monitored through the Blynk application, which sends soil pH data, solution height, and pump activity notifications from the NodeMCU ESP32 microcontroller via the internet for real-time remote monitoring.

## REFERENCE

- Anggraeni, N. (2022). Potensi anggrek Indonesia di tengah pandemi Covid-19. *Pemikiran Masyarakat Ilmiah Berwawasan Agribisnis*, 8(2), 639–648.
- Anwar, K., Syauqy, D., & Fitriyah, H. (2018). Sistem pendeteksi kandungan nutrisi dalam tanah berdasarkan warna dan kelembapan dengan menggunakan metode Naive Bayes. *Jurnal Pengembangan Teknologi Informasi dan Ilmu Komputer*, 2(9), 2491–2498. <http://j-ptiik.ub.ac.id>.
- Arasada, B. (2017). Aplikasi sensor ultrasonik untuk deteksi posisi jarak pada ruang menggunakan Arduino Uno. *Jurnal Teknik Elektro*, 6(2), 137–145.
- Arifin, J., Zulita, L. N., & Hermawansyah. (2016). Perancangan muotomatis menggunakan mikrokontroler Arduino Mega 2560. *Jurnal Media Infotama*, 12(1), 89–98.
- Daniel, R., Utomo, A. D. N., & Setyoko, Y. A. (2022). Rancangan bangun alat monitoring kelembaban, pH tanah dan pompa otomatis pada tanaman tomat dan cabai. *Open Access Ledger*, 1(4), 161–170. <https://doi.org/10.20895/LEDGER.V1I4.862>
- De, L. C., & Singh, R. (2018). Organic production of Cymbidium orchids. *Acta Scientific Agriculture*, 2(4), 1–6. <https://www.researchgate.net/publication/335443737>.
- Djule, R., Wildian, R., & Firmawati, N. (2018). Rancang bangun prototipe sistem kontrol pH tanah untuk tanaman bawang merah menggunakan sensor E201-C. *Jurnal Fisika Unand*, 7(1), 63–68.
- Garvita, R. V., & Damhuri, D. (2022). Koleksi anggrek Cymbidium di Kebun Raya Bogor sebagai upaya konservasi eks situ. *Prosiding Seminar Nasional Masyarakat Biodiversitas Indonesia*, 8(1), 62–70. <https://doi.org/10.13057/psnmbi/m080109>
- Hananto, F. S., Santoso, D. R., & Julius. (2011). Application of piezoelectric material film PVDF (Polyvinylidene fluoride) as a liquid viscosity sensor. *Jurnal Neutrino*, 3(2), 129–142.
- Kumar, S., Babankumar, Thakur, R., Kumar, M., & Professor, A. (2015). Soil pH sensing techniques and technologies: A review. *International Journal of Advanced Research in Electrical, Electronics and Instrumentation Engineering*, 4(5), 4452–4456. <https://doi.org/10.15662/ijareeie.2015.0405077>
- Purba, T., et al. (2021). *Tanah dan nutrisi tanaman*. Medan.
- Rachmawati, A. Y., & Wardiyati, T. (2017). Pengaruh pH tanah dan pupuk NPK terhadap pertumbuhan dan warna bunga Hortensia (*Hydrangea macrophylla*). *PLANTROPICA Journal of Agricultural Science*, 2(1), 23–29.
- Riyanto. (2014). *Validasi & verifikasi metode uji sesuai dengan ISO/IEC 17025 laboratorium pengujian dan kalibrasi* (1st ed.). Deepublish.
- Rozaq, I. A., & Setyaningsih, N. Y. D. (2018). Karakterisasi dan kalibrasi sensor pH menggunakan Arduino Uno. *Prosiding SENDI U*, 1(1), 244–247.
- Sari, V. F., Ekawita, R., & Yuliza, E. (2021). Desain bangun pH tanah digital berbasis Arduino Uno. *JoP*, 7(1), 36–41.
- Syam, R. (2013). *Dasar-dasar teknik sensor*. Universitas Hasanuddin.
- Syukhron, I., Rahmadewi, R., & Ibrahim. (2021). Penggunaan aplikasi Blynk untuk monitoring dan kontrol jarak jauh pada sistem kompos pintar berbasis IoT. *Jurnal Rekayasa dan Teknologi Elektro*, 15(1), 2–9.
- Ulum, M. B., Lutfi, M., & Faizin, A. (2022). Otomatisasi pompa air menggunakan NodeMCU ESP8266 berbasis Internet of Things (IoT). *Jurnal Mahasiswa Teknik Informatika*, 6(1), 86–93.
- Warjono, S., Wisaksono, A., Misbahur, A., Amalia, D., & Mubarak, M. H. (2017). Alat ukur elektronik pemakaian air. *ORBITH*, 13(2), 86–89.

- Widyatmika, I. P. A. W., Indrawati, N. P. A. W., Prastya, I. W. W. A., Darminta, I. K., Sangka, I. G. N., & Saptaka, A. A. N. G. (2021). Perbandingan kinerja Arduino Uno dan ESP32 terhadap pengukuran arus dan tegangan. *Jurnal Otomasi, Kontrol, & Instrumentasi*, 13(1), 37–45.
- Yudhanto, Y., & Aziz, A. (2019). *Pengantar teknologi Internet of Things*. UNS Press.