

Design of a Web Based Workshop Management Information System Application Using Rapid Application Development Techniques

Nurfathán Samnaufal Razzaq^{1*}, Renny Sari Dewi²

Department of Digital Business, Faculty of Economics, Universitas Negeri
Surabaya

nurfathan.21031@mhs.unesa.ac.id

Abstract

The rapid pace of digital transformation across industries requires all sectors, including the automotive service industry, to adopt technology in order to enhance operational efficiency and competitiveness. This study aims to design and develop a web-based Management Information System (MIS) for CV XYZ, a workshop that has been relying on manual methods for its transaction and data recording processes. These manual practices have led to problems such as delayed recordkeeping, risk of data loss, and inaccurate inventory information. To address these issues, this research adopts a qualitative approach combined with the Rapid Application Development (RAD) method, which emphasizes speed and flexibility in system development. The process involves analyzing user needs, designing user interfaces, implementing the system, and conducting system testing. The results show that the developed web-based MIS significantly improves data management related to services, spare parts, mechanics, and transactions in a faster, more accurate, and integrated manner. User Acceptance Testing (UAT) conducted with the business owner revealed a 100% satisfaction rate with all developed system features. These findings indicate that implementing the MIS not only increases the operational efficiency of the workshop but also supports data-driven decision-making in real time. Theoretically, this research contributes to a deeper understanding of the RAD method in the context of system development for micro, small, and medium enterprises (MSMEs), and it serves as a reference for similar initiatives in other sectors.

Keywords: Management Information System, Workshop, RAD, Web Application, MSME Digitalization

Received: 1 June 2025; Accepted: 25 July 2025; Published: December 2025

*Corresponding author

To cite this document:

Razzaq, N. S., & Dewi, R. S. (2025). Design of a Web Based Workshop Management Information System Application Using Rapid Application Development Techniques. *JDBIM (Journal of Digital Business and Innovation Management)*, Vol. 4 Np. 2, pp. 332-358. [DOI link](#)

Email: nurfathan.21031@mhs.unesa.ac.id

Abstrak

Transformasi digital dalam dunia industri menuntut setiap sektor untuk mengadopsi teknologi guna meningkatkan efisiensi dan daya saing, termasuk dalam sektor otomotif. Penelitian ini bertujuan untuk merancang dan mengembangkan Sistem Informasi Manajemen (SIM) berbasis web pada CV XYZ, sebuah bengkel yang selama ini masih menggunakan metode manual dalam proses transaksi dan pencatatan data. Permasalahan yang timbul akibat metode manual tersebut antara lain keterlambatan pencatatan, risiko kehilangan data, serta ketidaktepatan informasi stok barang. Untuk menjawab tantangan tersebut, penelitian ini menggunakan pendekatan kualitatif dan metode pengembangan sistem Rapid Application Development (RAD) yang menekankan pada kecepatan dan fleksibilitas proses pembangunan sistem. Tahapan yang dilakukan meliputi analisis kebutuhan pengguna, perancangan antarmuka, implementasi sistem, hingga uji coba aplikasi. Hasil dari pengembangan sistem menunjukkan bahwa SIM berbasis web mampu membantu dalam manajemen data servis, data suku cadang, mekanik, serta transaksi secara lebih cepat, akurat, dan terintegrasi. Evaluasi melalui User Acceptance Test (UAT) terhadap pemilik bengkel menunjukkan tingkat penerimaan sebesar 100% terhadap seluruh fitur yang dikembangkan. Temuan ini mengindikasikan bahwa implementasi SIM tidak hanya meningkatkan efisiensi operasional bengkel, tetapi juga mendukung pengambilan keputusan berbasis data secara real-time. Secara teoritis, studi ini memberikan kontribusi pada pemahaman penerapan metode RAD dalam pengembangan sistem informasi untuk usaha kecil dan menengah (UKM), serta dapat dijadikan referensi bagi pengembangan sistem serupa di sektor lainnya.

Kata kunci: Sistem Informasi Manajemen, Bengkel, RAD, Web Application, Digitalisasi UMKM.

INTRODUCTION

In the era of rapid technological advancement and digital transformation, the role of Management Information Systems (MIS) has become increasingly critical (Ritonga, R. K., & Firdaus, R. (2024)). The digital transformation compels all industry sectors to adapt to information technology to boost competitiveness and service efficiency. Information systems enable companies to align with technological developments, streamline business processes, and enhance customer service. One optimization example is the implementation of MIS in daily operational management, such as transaction logging, inventory control, service monitoring, and integrated real-time customer data storage (Prasad et al., 2023). MIS has become a vital component across various industries, including automotive workshops (Purba, 2019).

In a business, the development of a modern MIS requires skilled human resources to serve as managers (Primawanti, E. P., & Ali, H. (2022)). A

Management Information System is an integrated part of a company's internal control system with capabilities to process and store data that assist the organization in executing its tasks. It accepts input data, processes it, and generates output in the form of information.

Information systems have been widely used by automotive companies to manage various internal data, including customer records, service history, and inventory of components, allowing for more accurate, responsive, and interconnected services (Winardi et al., 2017). MIS is now applied in vehicle service centers like the Astra Honda Authorized Service Station (AHASS), enabling online service booking through official websites (Mulawarman et al., 2023). Similarly, Yamaha has adopted several information systems, including applications like Y-Connect and My Yamaha Motor, along with web-based platforms, to facilitate customer access to services and product information.

CV XYZ is a workshop engaged in vehicle servicing and spare parts sales, located in Sidoarjo. Currently, this workshop still conducts transactions manually when serving its customers. For instance, service data is recorded in notebooks, and spare part sales are hindered by the lack of fast and accurate stock information. Previous research on MIS implementation at Ikhsan Jaya Motor Workshop showed that such systems could enhance operational efficiency and reduce errors caused by manual data handling Nurlaila, D., & Mulyono, H. (2023). MIS offers convenient access, fast processing, and a more secure and structured data storage system (Hidayati, 2021).

Considering the issues faced by CV XYZ, the development of a web-based workshop management information system is proposed. This system is expected to facilitate the workshop owner in accessing crucial information such as spare part availability. The choice of a web platform is based on its advantage of flexible access anytime and anywhere via internet connection and independence from the device's operating system (Manik et al., 2017).

This study is expected to provide both practical and theoretical benefits. Practically, the web-based system at CV XYZ can enhance operational efficiency, data accuracy, faster decision-making, and support business sustainability amid the automotive industry competition. Theoretically, it expands the understanding of RAD implementation in small and medium enterprises and serves as a reference for developing similar systems in other sectors (Hamka et al., 2021).

METHODS

This study employs a qualitative approach integrated with the Rapid Application Development (RAD) method for system development. The qualitative method focuses on exploring and understanding phenomena through participants' perspectives. It involves descriptive data collection, typically in the form of spoken or written narratives (Sahir, 2021).

The qualitative approach was chosen to understand and describe the functional needs of the Management Information System for CV XYZ. RAD was selected because it allows for quicker and more iterative system development, making it more efficient in meeting user requirements and accommodating changes during development. This approach emphasizes user requirements analysis, interface design, system implementation, and testing in an operational environment. Metode RAD menggabungkan sejumlah tahapan inti, seperti perencanaan awal, desain secara cepat, pembuatan prototipe, dan proses uji coba, yang keseluruhannya bertujuan untuk mempercepat tahapan pengembangan sistem dan menghasilkan produk akhir yang berkualitas tinggi. The RAD method comprises key stages such as initial planning, rapid design, prototyping, and testing. These stages aim to accelerate system development and produce a high-quality final product that meets user expectations.

RESULT AND DISCUSSION

Requirement Planning

System planning is the initial stage in development, aimed at identifying the main objectives and defining the information needs that the system must fulfill. This phase also focuses on addressing the current problems. The author conducted an analysis of the issues faced by CV XYZ.

Current System Analysis

After observing the ongoing business processes, CV XYZ Workshop can receive many transactions, both from motorcycle service and motorcycle spare part sales, along with the increasing number of customers who come every day. However, until now administrative activities such as stock management and transaction recording are still done manually by recording in a notebook. When a customer wants to buy a spare part, they usually ask first whether the item is available. The admin then checks stock availability to the warehouse. After receiving information from the warehouse, the admin will notify the customer again whether the requested spare part is available or not.

Problem Identification

Based on the current business flow, it appears that customer service is still manual and inefficient. When a customer inquires about spare part availability, the admin must first check with the warehouse. Only after receiving a response can the admin inform the customer whether the item is available. This process is quite time-consuming, especially when there are a large number of customers. Furthermore, there is no system for automatically recording stock, so availability information can be inaccurate. If an item is unavailable, the customer will not make a purchase, and the workshop will lose sales opportunities.

Needs Analysis

The workshop's business processes still have weaknesses, one of which is the inefficient way of checking spare parts availability. Admins have to travel back and forth to the warehouse, slowing down service, especially during peak customer periods. Given these challenges, a system is needed that can automatically process and store inventory data. With structured data management, the workshop will be able to more easily control inventory, improve work efficiency, and provide faster and more accurate service to customers.

Functional Requirements:

The Management Information System developed must have the following functional requirements:

- Incoming item management
- Outgoing item management
- Mechanic management
- Service management

Non-functional Requirements:

Non-functional requirements act as supporting elements in a system's performance. Although their influence isn't directly visible during the development process, their presence is crucial. The following are non-functional aspects that support system development:

A. Software Requirements:

- Windows 11
- 64-bit Operating System
- Web Browser
- XAMPP
- PHPRunner

B. Hardware Requirements:

- 8 GB RAM
- Mouse and Keyboard
- AMD Ryzen 5 5500U with Radeon Graphics
- Wi-Fi Internet Connection

Design Workshop

Use Case Diagram

Use case diagrams describe the main functions of a system based on the user's perspective. This diagram serves to show how the interaction amongst each actor (both users and external systems) and the designed system, as well as explaining the flow or scenario of actions taken by users and systems to achieve certain goals (Setiyani, 2021). In the display of the use case diagram of the SIM Workshop application which has two actors and 6 cases.

1. Use Case Scenario Manage Mechanics
2. Use Case Scenario Manage Item Data
3. Use Case Scenario Manage Incoming Item
4. Use Case Scenario Manage Item Transactions
5. Use Case Scenario Manage Service
6. Use Case Scenario Manage Service Transactions

A. Activity diagram

Activity diagram is a visual representation used to describe the sequence of activities or processes in a system, starting from the initial steps to the completion stage (Annisa Tri Hidayati et al., 2023). Some activity diagrams for the system to be created are shown in the following figure.

1. Diagram Mechanic Activity

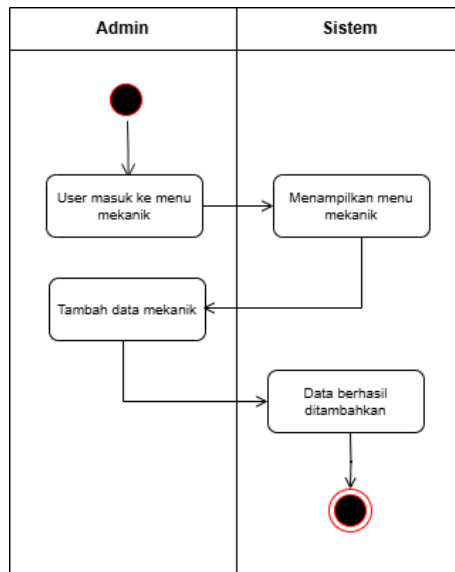

Figure 1 Mechanic Activity Diagram

Figure 1 is a display of the activity diagram of the mechanic menu in the SIM Workshop application.

2. Item Data Activity Diagram

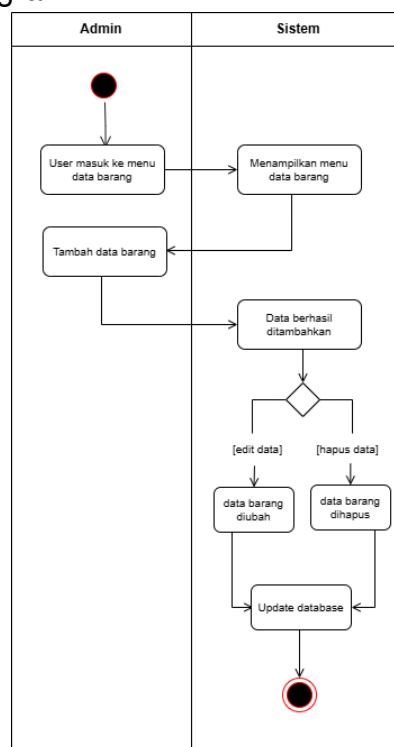

Figure 2 Activity Diagram of Item Data

Figure 2 is an activity diagram of the mechanic menu in the SIM Workshop application.

3. Activity Diagram of incoming items

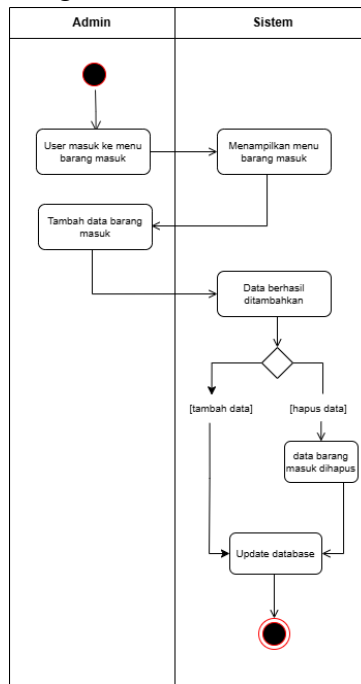

Figure 3 Activity Diagram of Incoming Items

Figure 3 shows the activity diagram of incoming items menu in the SIM Workshop application.

4. Item Transaction Activity Diagram

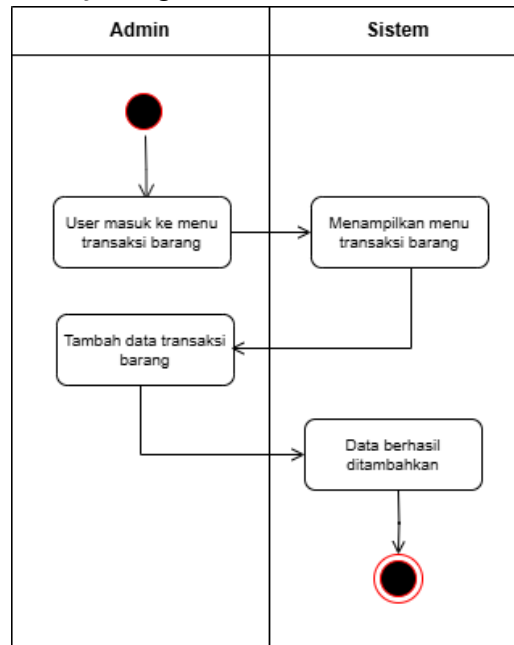

Figure 4 Activity Diagram of Items Transaction

In Figure 4 is a display of the activity diagram of item transactions in the SIM Workshop application.

5. Service Activity Diagram

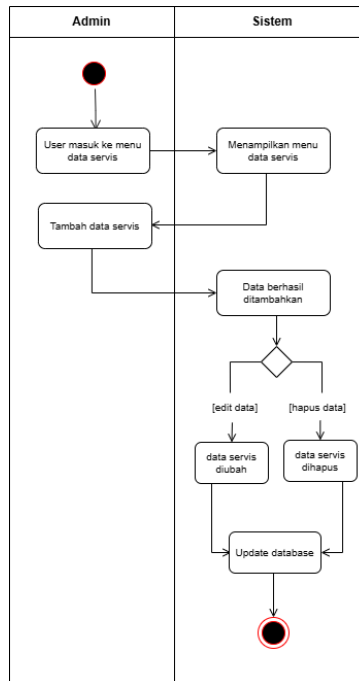

Figure 5 Service Activity Diagram

Figure 5 is a display of the activity diagram of the service menu in the SIM Workshop application.

6. Service Transaction Activity Diagram

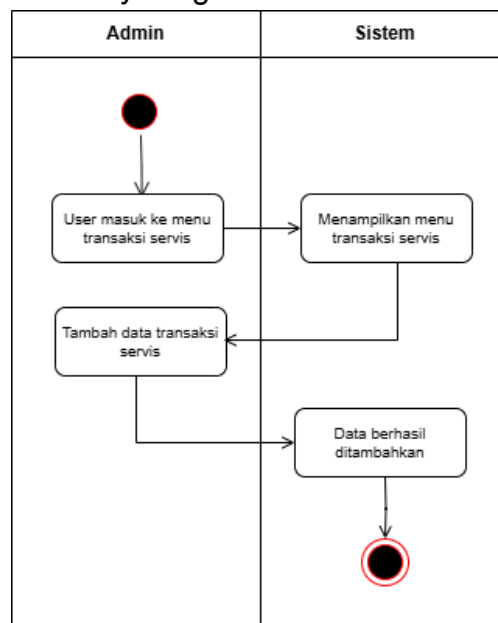

Figure 6 Service Transaction Activity Diagram

In Figure 6 is a display of the activity diagram of the service transaction menu in the SIM Workshop application.

B. Sequence Diagram

Sequence diagram represents how objects behave in a use case, by showing the life cycle of each object and the interaction in the form of messages sent and received between these objects (Aprianti & Maliha, 2016). The following is a sequence diagram that illustrates the flow of communication between objects.

1. Mechanical Sequence Diagram

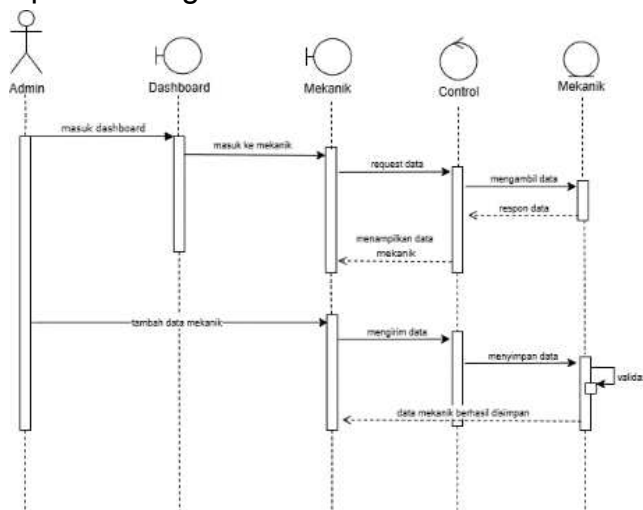

Figure 7 Mechanic Sequence Diagram

Figure 7 is a view of the sequence diagram of the mechanic.

2. Sequence Diagram of Item

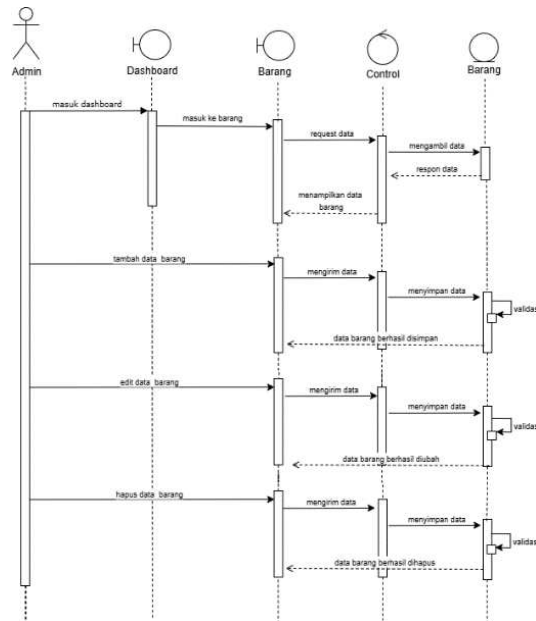

Figure 8 Item Sequence Diagram

In Figure 8 is a display of the sequence diagram of an item.

3. Incoming Item Sequence Diagram

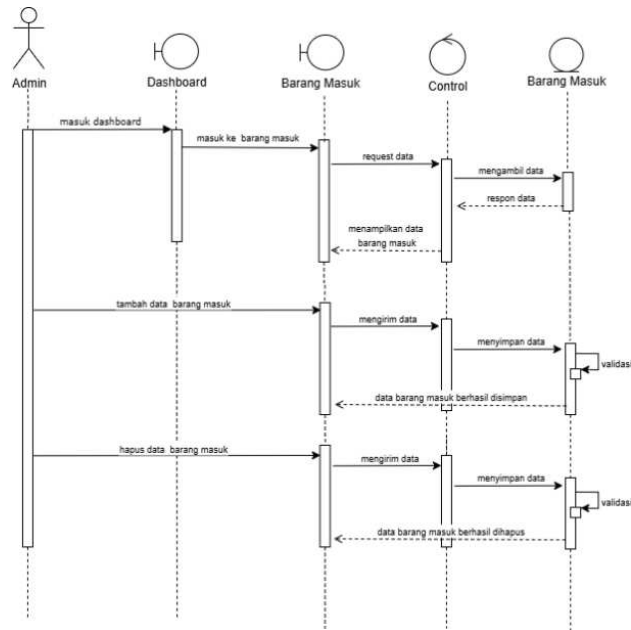

Figure 9 Incoming Items Sequence Diagram]

Figure 9 is a display of the sequence diagram of incoming item.

4. Service Sequence diagram

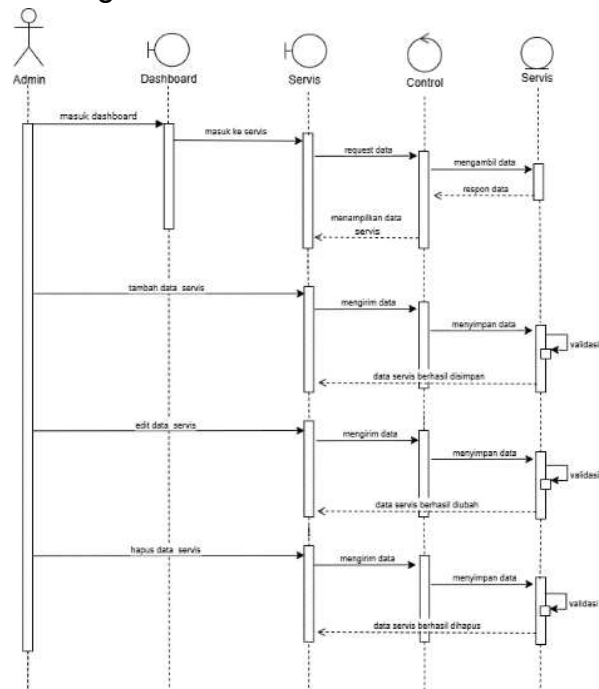

Figure 10 Service Sequence Diagram

In Figure 10 is a display of the sequence diagram of the service.

5. Sequence Diagram of Item Transaction

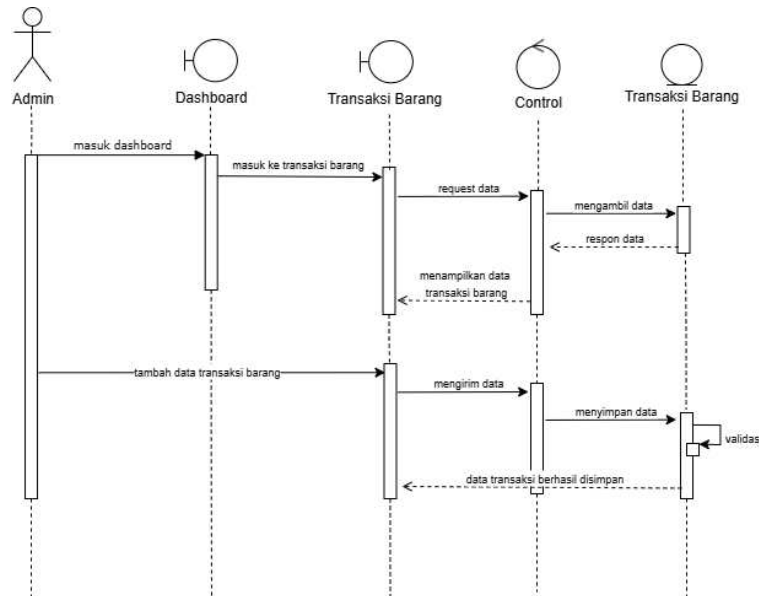

Figure 11 Sequence Diagram of Items Transaction

In Figure 11 is a display of the sequence diagram of item transactions.

6. Transaction Sequence diagram

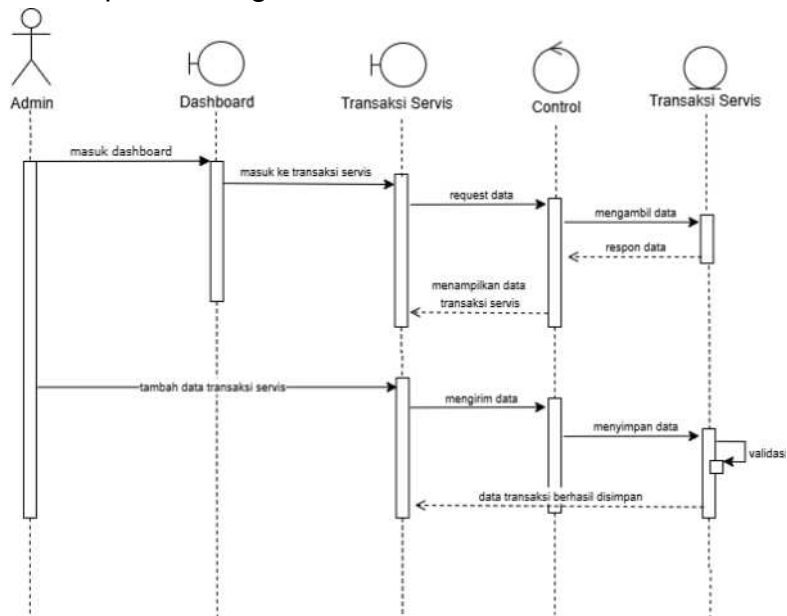

Figure 12 Service Transaction Sequence diagram

Figure 12 is a display of the sequence diagram of service transactions.

C. Class Diagram

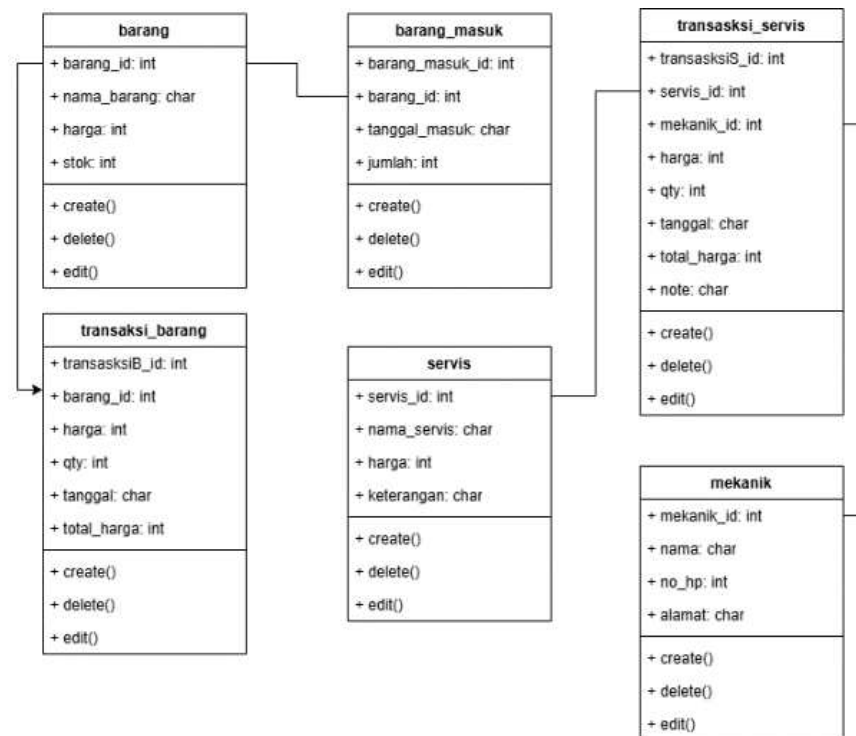

Figure 13 Class Diagram of Workshop Management Information System

Desain Database

A. Desain Tabel

In making this system there are 6 tables, namely:

1. Mechanical Table
The mechanical table is used to store data on the mechanical menu.
2. Goods Table
The goods table is used to store data on the goods menu.
3. Incoming Goods Table
The mechanical table is used to store data on the mechanical menu.
4. Service Table
The service table is used to store data on the service menu.
5. Goods Transaction Table
The goods transaction table functions as a data storage area related to activities on the goods transaction menu.
6. Service Transaction Table
The service transaction table is used to store data on the service transaction menu.

Interface Design

1. Dashboard

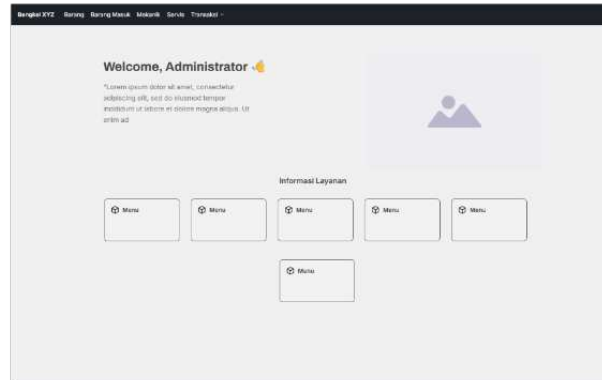

Figure 14 Dashboard Wireframe

Wireframe of the dashboard page of the CV XYZ Workshop Management System website is shown in Figure 14.

2. Item

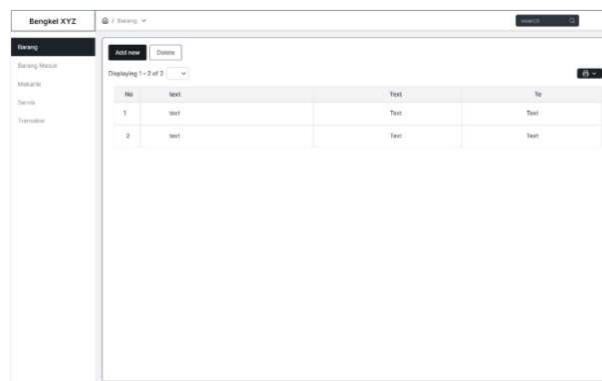

Figure 15 Wireframe of Item Data

Wireframe of the item page of the CV XYZ Workshop Management System website is shown in Figure 15.

3. Items In

Nurfathan Samnaufal Razzaq, Renny Sari Dewi
Design of a Web Based Workshop Management Information System Application
Using Rapid Application Development Techniques

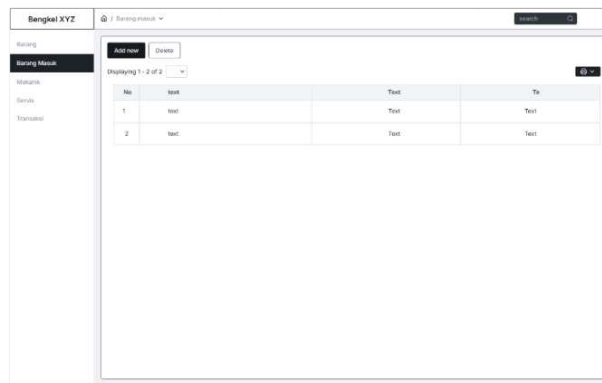

Figure 16 Wireframe of Incoming Items

Wireframe of the Items In page of the CV XYZ Workshop Management System website is shown in Figure 16.

4. Mechanic

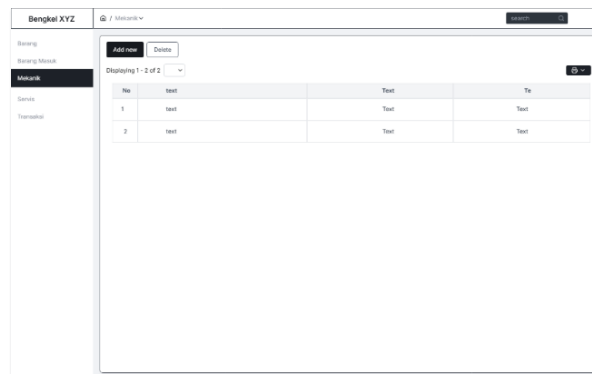

Figure 17 Mechanic Wireframe

Wireframe of the Mechanic page of the CV XYZ Workshop Management System website is shown in Figure 17.

5. Service

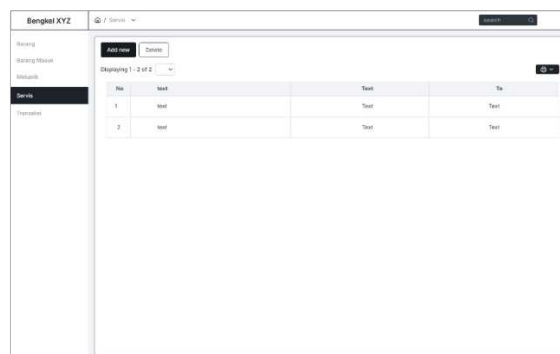

Figure 18 Service Wireframe

Wireframe of the service page of the CV XYZ Workshop Management System website is shown in Figure 18.

6. Items/service transaction

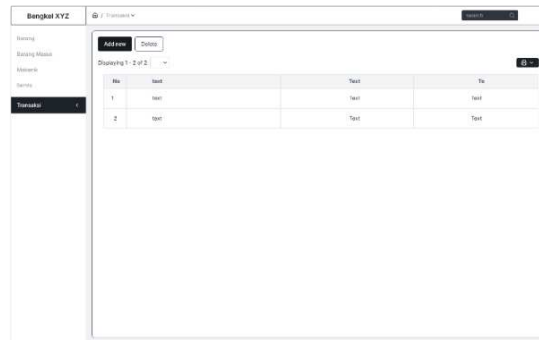

Figure 19 items/service transaction Wireframe

Wireframe of the transaction page of the CV XYZ Workshop Management System website is shown in Figure 19.

7. Input Data



Figure 20 data input Wireframe

Wireframe of data input display from the CV Rejeki XYZ Workshop Management System website is shown in Figure 20.

Build

After the system design is complete, the next step is to build the application using the PHPRunner tool. PHPRunner was chosen because it supports the development of web-based applications quickly and efficiently. As for the database design, it will use MySQL.

A. Database

The database is used to store data in the Management Information System application which consists of six databases as follows.

1. Mechanic database

Nurfathan Samnaufal Razzaq, Renny Sari Dewi
 Design of a Web Based Workshop Management Information System Application
 Using Rapid Application Development Techniques

#	Name	Type	Collation	Attributes	Null	Default	Comments	Extra
1	mekanik_id	int(15)			No	None		AUTO_INCREMENT
2	nama	varchar(150)	utf8mb4_general_ci		No	None		
3	no_hp	varchar(15)	utf8mb4_general_ci		No	None		
4	Alamat	text	utf8mb4_general_ci		No	None		

Figure 21 Mechanic Database

Figure 21 is a view of the mechanic database

2. Item Database

#	Name	Type	Collation	Attributes	Null	Default	Comments	Extra
1	barang_id	int(15)			No	None		AUTO_INCREMENT
2	nama_barang	varchar(150)	utf8mb4_general_ci		No	None		
3	harga	int(15)			No	None		
4	stok	int(11)			No	None		

Figure 22 Item Database

Figure 21 is a view of the item database

3. Incoming Item Database

#	Name	Type	Collation	Attributes	Null	Default	Comments	Extra
1	barang_masuk_id	int(15)			No	None		AUTO_INCREMENT
2	barang_id	int(15)			No	None		
3	tanggal_masuk	date			No	None		
4	jumlah	int(15)			No	None		

Figure 23 Incoming Items Database

Figure 23 is a view of the incoming item database

4. Service Database

#	Name	Type	Collation	Attributes	Null	Default	Comments	Extra
1	servis_id	int(11)			No	None		AUTO_INCREMENT
2	nama_servis	varchar(150)	utf8mb4_general_ci		No	None		
3	harga	int(11)			No	None		
4	keterangan	text	utf8mb4_general_ci		No	None		

Figure 23 Service Database

Figure 24 is a view of the service database.

5. Items Transaction Database

#	Name	Type	Collation	Attributes	Null	Default	Comments	Extra
1	transaksiB_id	int(11)			No	None		AUTO_INCREMENT
2	barang_id	int(11)			No	None		
3	harga	int(11)			No	None		
4	qty	int(11)			No	None		
5	tgl	date			No	None		
6	total_harga	int(11)			No	None		

Figure 25 Items Transaction Database

Figure 25 is a view of the items transaction database

6. Service Transaction Database

#	Name	Type	Collation	Attributes	Null	Default	Comments	Extra
1	transaksiS_id	int(11)			No	None		AUTO_INCREMENT
2	servis_id	int(11)			No	None		
3	mekanik_id	int(11)			No	None		
4	harga	int(11)			No	None		
5	qty	int(11)			No	None		
6	tanggal	date			No	None		
7	total_harga	int(11)			No	None		
8	note	text	utf8mb4_general_ci		No	None		

Figure 26 Items Service Transaction Database

Figure 25 is a view of the service transaction database

B. Develop Application

The application development stage is the process of realising the system design that has been prepared previously. At this stage, the application begins to be built and implemented in accordance with the needs and designs that have been designed. In this development, a tool called PHPRunner is used. PHPRunner is a software that allows the creation of web-based applications automatically, where users can generate web pages without the need to write code manually. The use of PHPRunner accelerates the development process and makes it easier to produce interactive and functional interfaces.

PHP is used as the programming language, while databases compatible with PHPRunner include MySQL, SQL Server, Oracle, and Microsoft Access.

Demonstrate

The author will demonstrate the completed application and introduce it to the user. New systems or components of systems are first tested before they are finally implemented into the organisational environment.

a. Main Page/Dashboard

Workshop Management Information System (SIM) application, which displays six main menus such as, mechanic menu, goods, incoming goods, service, goods transactions, and service transactions.

b. Item Data Menu Display

The following item data management page in SIM Bengkel displays a main table that contains a complete list of available item information. In addition, this page is also equipped with action buttons that allow users to add, edit, or delete item data as needed.

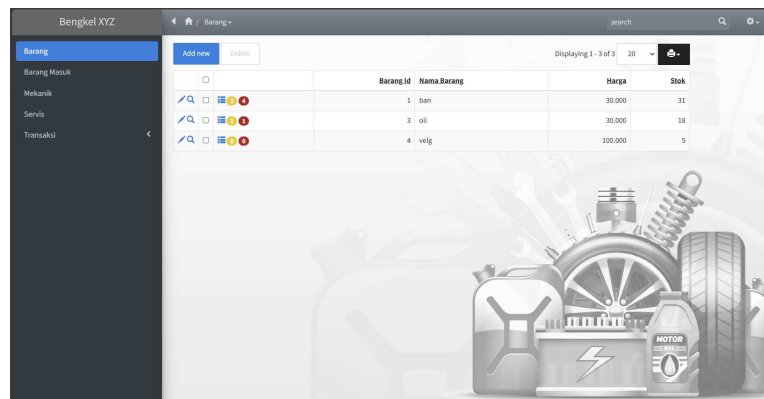

Barang Id	Nama Barang	Harga	Stok
1	ban	30.000	31
3	oli	30.000	18
4	velg	100.000	5

Figure 27 Display of Item Data Menu

c. Display of Item Data Form

Below is a display of the form page for adding item data. There are, name, price, stock quantity.

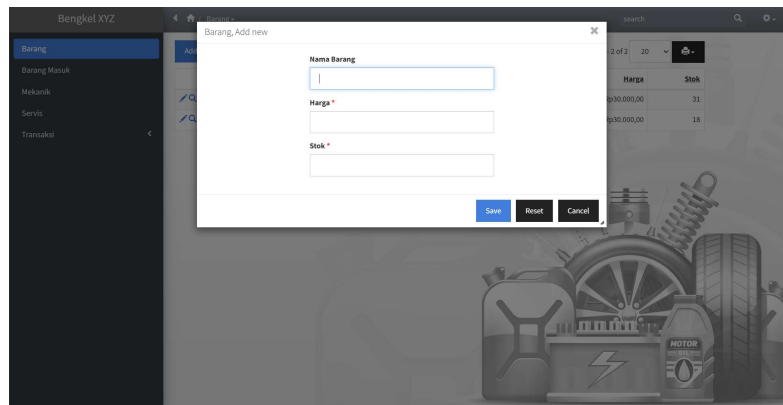

Figure 28 Item Data Input Form

d. Incoming Item Display

The following is a view of the incoming items page that presents information such as the name of the item, the date the item was received, and the quantity. This page is also equipped with action buttons that allow users to add, edit, or delete data as needed.

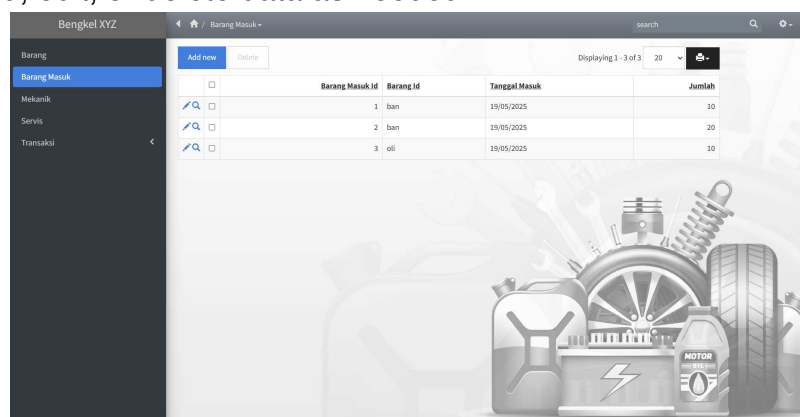

Figure 29 Display of Incoming Items

e. Display of Incoming Items Form

The following is a display of the form page for adding item data, which consists of several fields such as the name of the item, the date entered, and the amount of stock available.

Nurfathan Samnaufal Razzaq, Renny Sari Dewi
Design of a Web Based Workshop Management Information System Application
Using Rapid Application Development Techniques

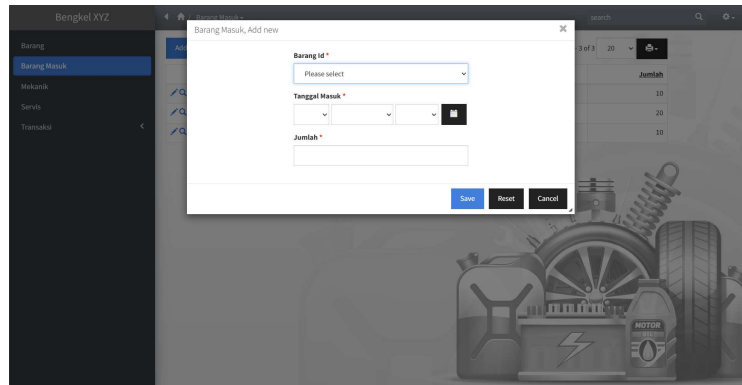

Figure 30 Input form for incoming items

f. Mechanical Data Display

Below is a mechanic view that displays data on mechanic names, mobile phone numbers, addresses and is equipped with action buttons to add, change, or delete data.

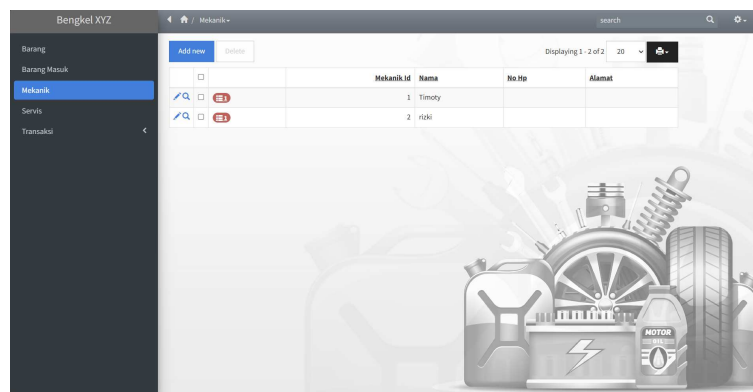

Figure 31 Mechanical Display

g. Service Data Display

Below is a view of the service menu that displays data on service names, prices, descriptions and is equipped with action buttons to add, change, or delete data.

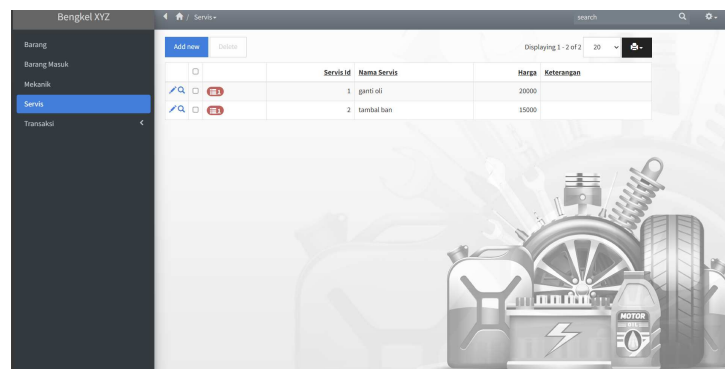

Figure 32 Service Display

h. Display of Service Data Form

The following is a view of the form page for entering service data, which contains fields such as service name, price, and additional information.

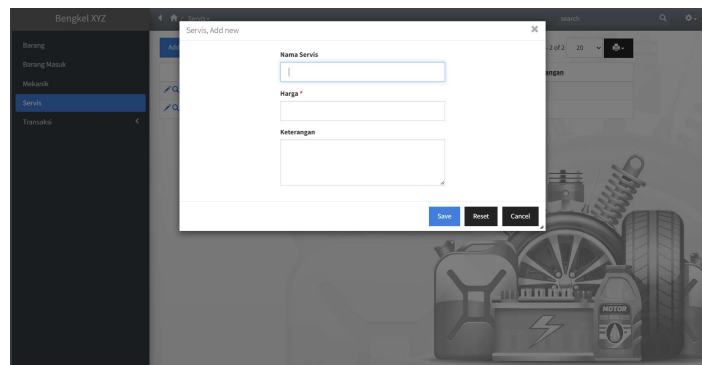

Figure 33 Display of Service Data Input Form

i. Item Transaction Display

The following is a view of the item transaction menu that presents detailed information about transaction data, including item price, quantity (qty), transaction date, total price and is equipped with action buttons to add, change, or delete data.

Transaksi Id	Barang Id	Harga	Qty	Tgl	Total Harga
2	ben	30,000	2	15/05/2025	60,000
3	ben	30,000	2	18/05/2025	60,000
4	ban	30,000	3	18/05/2025	90,000
5	oil	30,000	2	15/05/2025	60,000

Figure 34 Item Transaction Display

j. Display of Item Transaction Form

The following is a view of the item transaction form page, which includes fields such as item name, unit price, quantity (qty), and date of transaction.

Nurfathansamnaul Razzaq, Renny Sari Dewi
Design of a Web Based Workshop Management Information System Application
Using Rapid Application Development Techniques

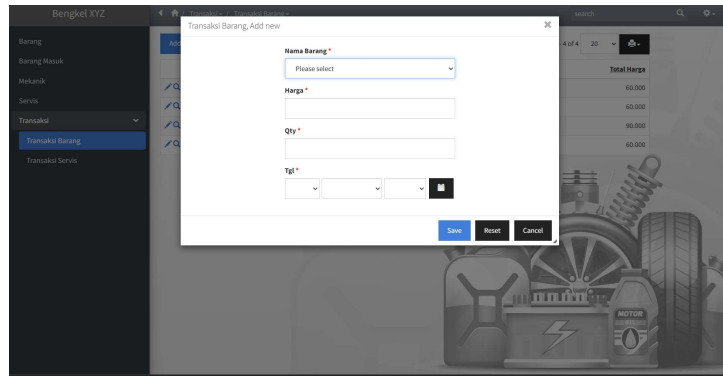

Figure 35 Display of Item Transaction Form

k. Service Transaction Display

Dibawah ini merupakan tampilan menu transaksi servis dan yang menampilkan data transaksi servis, mekanik, qty, tanggal, total harga, keterangan dan dilengkapi dengan tombol aksi untuk menambahkan, mengubah, atau menghapus data

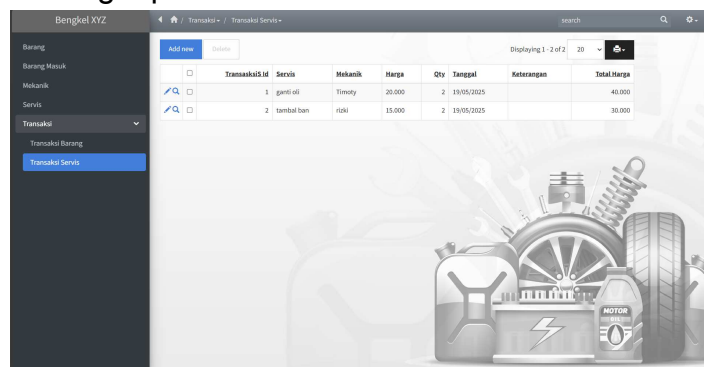

Figure 36 Service Transaction Display

l. Display of Service Transaction Form

The following is a view of the service transaction form page. There are input form, service, mechanic, qty, transaction date price and description.

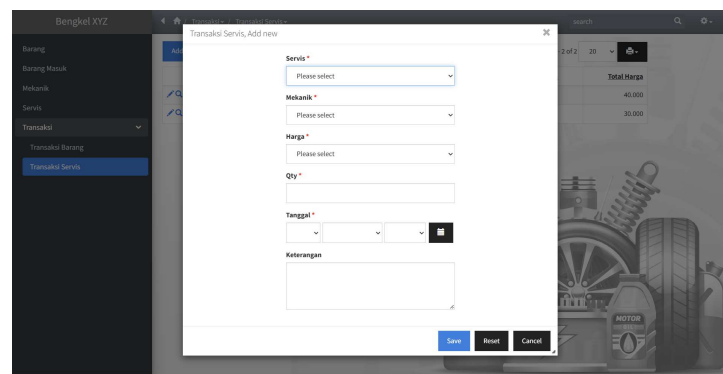

Figure 37 Display of Service Transaction Input Form

Testing

To measure the extent to which the Workshop Management Information System application is accepted by users, an evaluation is carried out using the User Acceptance Test (UAT) method which is realised in the form of a questionnaire or form. Responses from partners who have tried the application are then analysed to assess the level of system acceptance by users.

Testing Results

Based on the results of UAT testing carried out, the results of the questionnaire were obtained against 9 features in the system. UAT is conducted to workshop owners and researchers make presentations about applications that have been made, then users fill out the questionnaire given. The result of UAT is 100% successful acceptance of the application features that have been made and can be seen in table 1.

Tabel 1 Hasil Pengujian

no	Fitur	Status
1	Navigation buttons work well	Success
2	Adding new item data	Success
3	Adding stock items	Success
4	Reducing stock when in use	Success
5	Automatically updated stock quantity	Success
6	Recording customer complaints	Success
7	Service data management	Success
8	Files can be printed or downloaded PDF	Success
9	Data search results according to keywords	Success

CONCLUSION

The development of a web-based Workshop Management Information System using the Rapid Application Development (RAD) approach was successfully carried out at CV XYZ. This system is able to facilitate the management of workshop data such as stock items, transactions, and mechanic data efficiently and accurately. Through a design process that includes activity diagrams, sequence diagrams, class diagrams, as well as database and user interface designs, this system has been tested and received a 100% success rate in User Acceptance Testing. These results show that the system is able to improve operational efficiency and support real-time data-based decision making. The use of the RAD method is proven to be effective in accelerating the development of applications that

meet user needs, as well as providing practical benefits for the small and medium business sector such as vehicle repair shops.

REFERENCES

- Annisa Tri Hidayati, Aditya Eka Widyantoro, & Hertas Jelang Ramadhani. (2023). Perancangan Sistem Informasi Wirausaha Mahasiswa (Siwirma) Berbasis Web dengan Unified Modelling Language (UML). *Jurnal Penelitian Rumpun Ilmu Teknik*, 2(4), 86–107. <https://doi.org/10.55606/juprit.v2i4.2906>
- Aprianti, W., & Maliha, U. (2016). *Sistem Informasi Kepadatan Penduduk Kelurahan Atau Desa Studi Kasus Pada Kecamatan Bati-Bati*. 2(2013), 21–28.
- Hamka, N. I., Prianto, C., & Rahayu, W. I. (2021). Analisis dan Perancangan Sistem Aplikasi Berbasis Website Untuk Sistem Manajemen Pendidikan dan Pelatihan Pada Whiteboard Edu. *Jutisi: Jurnal Ilmiah Teknik Informatika Dan Sistem Informasi*. <https://doi.org/10.35889/jutisi.v10i3.710>
- Hidayati, L. (2021). *EVALUASI SISTEM INFORMASI MANAJEMEN TERHADAP PENGGUNA DALAM Mendukung Pengelolaan Obat Dipuskesmas Kabupaten Bantul*. 2, 116–124. <https://doi.org/10.36760/JP.V2I1.168>
- Kurniawan Ritonga, R., & Firdaus, R. (2024). Pentingnya Sistem Informasi Manajemen Dalam Era Digital the Importance of Management Information Systems in the Digital Era. *JICN: Jurnal Intelek Dan Cendekiawan Nusantara*, 1(3), 4353–4358.
- Manik, A., Salamah, I., & Susanti, E. (2017). Pengaruh Metode Webqual 4.0 Terhadap Kepuasan Pengguna Website Politeknik Negeri Sriwijaya. *Jurnal Elektro Dan Telekomunikasi Terapan (e-Journal)*, 4(1), 477.
- Mulawarman, L., Jatmiko Jati, L., Anggriani, R., & Umiyatun, R. (2023). Analisis Efektivitas Pelayanan Booking Service Online Honda AHASS: Studi Kasus pada Pengguna Honda di Lingkungan Mahasiswa Universitas Bumigora. *ETNIK: Jurnal Ekonomi Dan Teknik*, 2(4), 310–316. <https://doi.org/10.54543/etnik.v2i4.176>
- Nurlaila, D., & Mulyono, H. (2023). *Sistem Informasi Manajemen Bengkel Berbasis Web pada Bengkel Ikhsan Jaya Motor* (Vol. 8, Issue 2).
- Prasad, R. H. C., Mounika, J., & Gopi, S. (2023). System for Managing Vehicle Services. *International Journal for Research in Applied Science and Engineering Technology*. <https://doi.org/10.22214/ijraset.2023.48618>
- Purba, M. M. (2019). Pemanfaatan Teknologi Informasi Dalam Bidang Industri Otomotif. *Jurnal Sistem Informasi Universitas Suryadarma*, 6(1), 160–170. <https://doi.org/10.35968/jsi.v6i2.282>
- Putri Primawanti, E., & Ali, H. (2022). Pengaruh Teknologi Informasi, Sistem Informasi Berbasis Web Dan Knowledge Management Terhadap Kinerja Karyawan (Literature Review Executive Support Sistem (Ess))

- for Business). *Jurnal Ekonomi Manajemen Sistem Informasi*, 3(3), 267–285. <https://doi.org/10.31933/jemsi.v3i3.818>
- Sahir, S. H. (2021). *Buku ini di tulis oleh Dosen Universitas Medan Area Hak Cipta di Lindungi oleh Undang-Undang Telah di Deposit ke Repository UMA pada tanggal 27 Januari 2022.*
- Setiyani, L. (2021). Desain Sistem: Use Case Diagram Pendahuluan. *Prosiding Seminar Nasional: Inovasi & Adopsi Teknologi 2021, September*, 246–260.
- Winardi, A., Farida, I., & Hariyanto, D. (2017). Rancang Bangun Sistem Informasi Manajemen Bengkel (Studi Kasus: CV . Anugrah Bogor). *IJSE – Indonesian Journal on Software Engineering*, 3(2), 8–14.