

## Design of a Detector System in Electrical Installations at Dize Photography Studio

Alwi Riski<sup>1</sup>, Muhammad Erpandi Dalimunthe<sup>2</sup>, Zuraidah Tharo<sup>3</sup>

Electrical Engineering Study Program, Faculty of Science And Technology, Pembangunan Panca Budi University,  
Jln. Jend.Gatot Subroto Km. 4,5 Medan Provinsi Sumatera Utara

Article Info	ABSTRACT
<b>Keywords:</b> phase failure detector, microcontroller, three phase system, electrical protection, and photography studio	The stability of a three-phase power supply is crucial for ensuring the reliable operation of photography studio equipment, which is generally sensitive to electrical disturbances. One common disturbance is phase failure, which can cause equipment damage, reduced work quality, and safety risks. This study aims to analyze and implement a microcontroller-based phase failure detector system capable of detecting abnormal conditions in a photography studio's electrical system quickly and accurately. The system is designed using an ATmega328P microcontroller integrated with voltage sensors on each phase. When one of the phases fails, the system will provide a warning via a buzzer and LED indicator, and can optionally disconnect the load to prevent further damage. Test results show that this detector is capable of detecting the loss of a phase in less than 1 second with an accuracy level of XX% (adjusted based on the results). Thus, this system can improve protection for studio equipment and support more reliable operations.
This is an open access article under the <a href="https://creativecommons.org/licenses/by-nc/4.0/">CC BY-NC</a> license 	<b>Corresponding Author:</b> Alwi Riski Electrical Engineering Study Program, Faculty of Science And Technology, Pembangunan Panca Budi University, Jln. Jend.Gatot Subroto Km. 4,5 Medan Provinsi Sumatera Utara <a href="mailto:awierizky13@gmail.com">awierizky13@gmail.com</a>

### INTRODUCTION

Electrical energy is a vital source of power for humans today. Almost all technologically advanced equipment requires electrical energy, making it a basic necessity. Electrical energy plays a vital role in both daily life and industry. This is because electrical energy is easily converted into other forms of energy. Three-phase electrical systems are widely used in industrial and commercial installations due to their efficiency in delivering large amounts of power consistently. One such application is in professional photography studios, where various equipment such as flashes, editing computers, and digital printers rely heavily on a quality power supply. However, a disruption in one phase, known as a phase failure, can cause serious damage to sensitive electronic equipment, reduce the quality of work, and potentially cause fires. Early detection of phase failures is crucial to minimize these risks. One solution is to design a microcontroller-based phase failure detection system. This system is capable of real-time monitoring of the voltage conditions on each phase, providing early warnings, and even activating automatic protection systems when a failure is

detected.

By utilizing microcontroller technology, this detection system can be made more flexible, affordable, and easily implemented in various small and commercial industrial environments, including photography studios. Therefore, this research aims to analyze and implement a reliable and efficient microcontroller-based phase failure detector.

In the distribution of electrical energy, system stability is essential to ensure consistent distribution to consumers. Maintaining this distribution system stability requires power quality and load on distribution transformers. However, in power distribution to consumers, attention must also be paid to load imbalances used by consumers to prevent failures and problems with power transformers. This load imbalance between each phase (phase R, phase S, phase T) causes neutral current to flow to the transformer. Protective equipment for phase failures caused by imbalances is essential, especially in three-phase voltage systems. The absence of a protective system can result in losses in the power transformer, overheating of one phase, reduced lifespan, reduced efficiency of the power transformer, and damage to fuses in the capacitor bank. Therefore, a reliable system is needed to monitor, notify, and cut off the current when a phase failure occurs.

## METHOD

The supporting equipment used to create the phase failure detector is as follows:

1. A soldering iron is used to heat the solder.
2. A drill is used to make holes in the PCB board.
3. Acrylic glue is used to adhere the material to the substrate.
4. Pliers are used to cut and strip the cables.

This research is an experimental applied research with a quantitative approach. The goal is to design, implement, and analyze the performance of a phase failure detection system in a three-phase electrical system, specifically in photography studio equipment, using a microcontroller as the control center. The research was conducted in the Electronics and Control Systems Laboratory and tested directly in a photography studio electrical installation that uses a three-phase power source. The implementation period is a specific timeframe (e.g., three months) from the design stage to system testing. The object of study is a phase failure detector system designed based on a microcontroller (e.g., Arduino Uno or ESP32), with testing conducted on photography studio equipment installations such as flash lamps, lighting controllers, and air conditioning systems that operate on three-phase power sources. All designed hardware and software components were assembled into a single phase detector system. Initial testing was conducted at a 220V AC input voltage per phase via a step-down transformer and a simulated load.

The testing was conducted by:

1. Applying normal three-phase voltage, then alternately disconnecting one of the phases (R, S, or T).
2. Observing the system response: buzzer activation, relay status, and LCD notifications.
3. Measuring the system's response time and stability to voltage and load variations.

The test results were analyzed to assess:

1. Phase failure detection speed.
2. Load disconnection accuracy.
3. System stability during continuous operation.
4. Development recommendations for industrial or IoT applications.

## RESULTS AND DISCUSSION

### System Design

A phase failure detector system was successfully designed using a microcontroller (e.g., Arduino Uno or ESP32) integrated with voltage sensors and relays. The microcontroller is capable of detecting the presence or absence of one of the three phases (R, S, T) by reading the voltage from each phase using a voltage divider and opto-isolator. When a phase fails, the system automatically:

- a. Activates a buzzer alarm.
- b. Disconnects power to the photography studio equipment by activating a relay.
- c. Displays the failure status via the LCD and/or serial monitor.

Testing was conducted by simulating the loss of each phase in turn.

- a. When the R phase was removed, the system responded in less than 1 second.
- b. A similar response occurred when the S or T phases were removed.
- c. No significant delay was observed between the input (voltage loss) and the output (protection activation).

The system operated stably under the following conditions:

- a. The input voltage varied between 180–240V.
- b. The photographic equipment load is between 500–1500 watts.
- b. No false alarms occur when all three phases are active.

Design Stages: The voltage sensor is used to read the input voltage. This device uses three sensors for the RST phase. The R voltage sensor is connected to analog pin A0, the S voltage sensor is connected to analog pin A1, and the T voltage sensor is connected to analog pin A2.

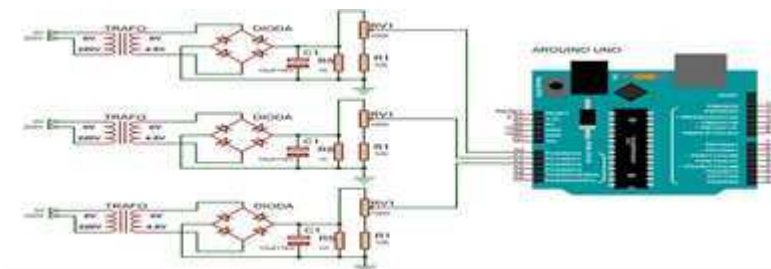
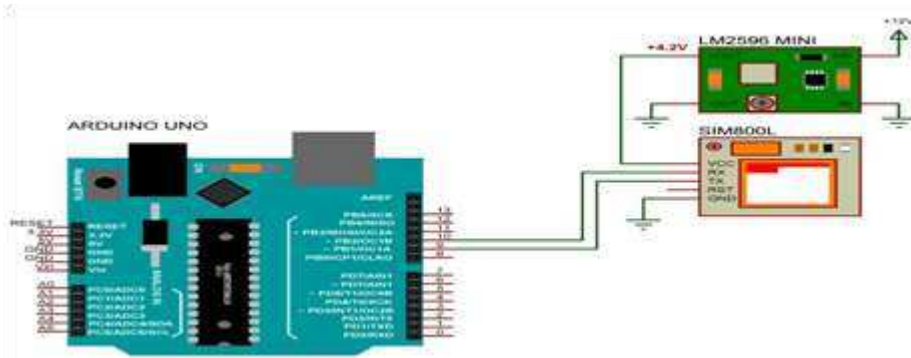

Figure 1. Voltage Sensor Circuit

The SMS module is used to notify users as remote information. The SMS module is connected to the Arduino Uno via digital pins. Digital pin 9 to the Sim800L TX pin, then digital pin 10 to the sim800L RX pin, the sim800L GND pin to the Arduino Uno GND pin. Because the sim800L only requires 4.2V DC power, we must use the LM2596 Mini regulator to lower the voltage from the Arduino Uno by connecting the 5V DC voltage pin

from the Arduino Uno to the LM2596 Mini first, after that the LM2596 Mini pin output to the VCC pin of the sim800L, the LM2596 GND pin to the Arduino Uno GND pin.



**Figure 2.** Sim800L Series

This module is used to display the condition of the voltage value in normal or abnormal conditions in text form. To connect the Arduino Uno to the LCD via the digital pins of the Arduino Uno, pin 7 to the RS pin of the LCD, Pin 6 to the E pin of the LCD, pin 5 to the D4 pin of the LCD, pin 4 to the D5 pin of the LCD, pin 3 to the D6 pin of the LCD, pin 2 to the D7 pin of the LCD, after that the VDD pin and the A pin of the LCD to the 5V DC pin of the Arduino Uno, the VEE pin on the LCD is connected to the 3kΩ resistor first then the output of the resistor to the GND pin of the Arduino Uno, the last VSS pin, RW pin and K pin on the LCD are connected to the GND pin of the Arduino Uno.

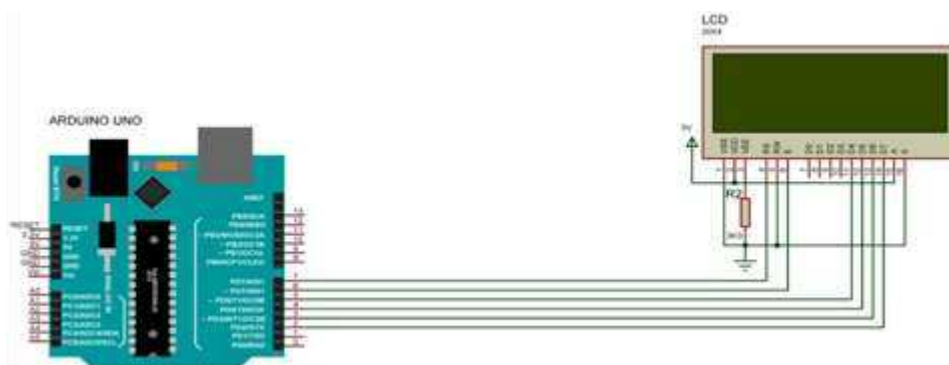

**Figure 3.** 20x4 LCD Circuit

The magnetic relay functions as an Arduino Uno controller to control the contactor either ON/OFF according to the settings of the Arduino Uno. To assemble the magnetic relay by connecting the TX pin on the magnetic relay to the digital pin 8 of the Arduino Uno and the GND pin of the magnetic relay to the GND pin of the Arduino Uno.

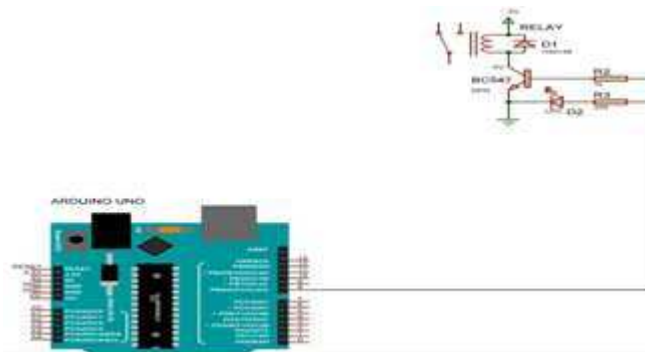

**Figure 4.** Magnetic Relay Circuit

MCB (Miniature Circuit Breaker) is used as the main switch of the device, the MCB input is connected to the RST phase then the MCB output is connected to the contactor input.

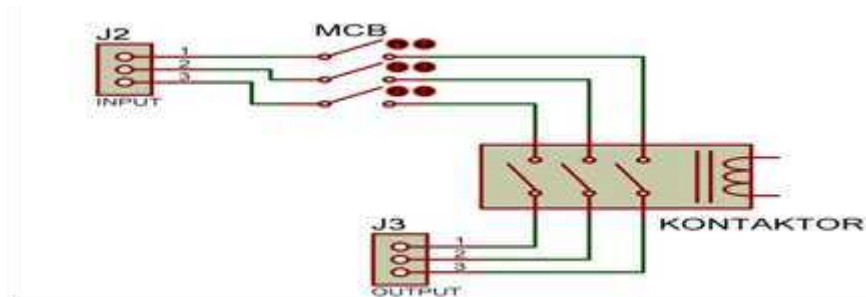

**Figure 5.** MCB circuit

The contactor acts as a voltage breaker and connector when receiving control from a magnetic relay. The RST output on the MCB is connected to the contactor input, after which the contactor output can be directly connected to a 3-phase load.

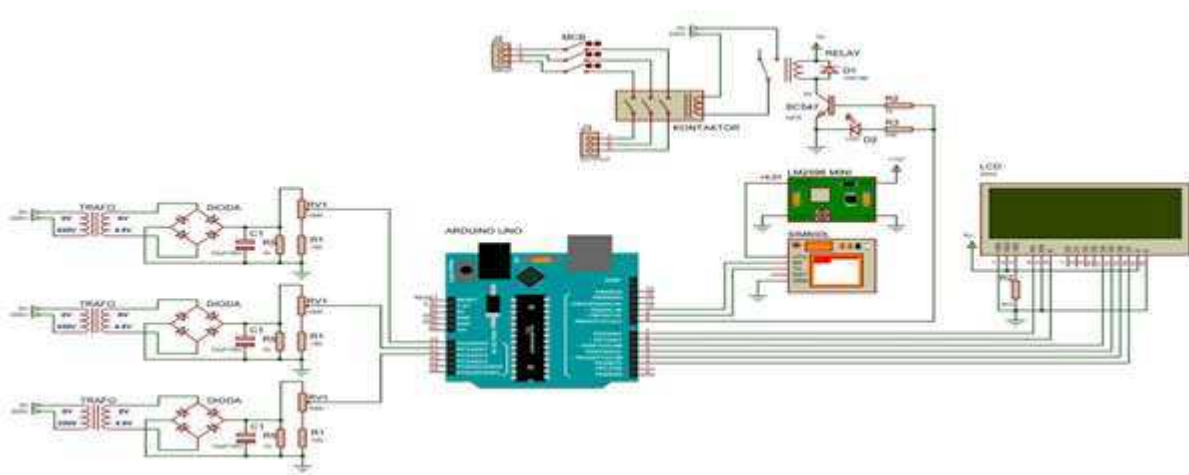

**Figure 6.** Wiring Diagram

Arduino Uno checks the RST voltage sensor and displays the voltage condition on the LCD, if the voltage is below 180V AC then the Arduino will disconnect the load then send an SMS to the user that a phase failure has occurred and display a warning status on the

LCD. However, if one of the voltages is read as 0V AC or one of the phases is disconnected then the Arduino Uno will disconnect the load and send an SMS to the user and provide a warning status on the LCD. If the voltage read is above 180V AC and one of the phases is not disconnected, the LCD will display a normal status.

#### Detection Effectiveness.

The system demonstrates high accuracy in detecting phase loss, which is crucial to prevent damage to motors or sensitive electronics in the studio. The system's response time of <1 second is highly effective in preventing current surges or dangerous load imbalances. The use of relays to immediately cut power when a phase is lost has proven effective in protecting expensive equipment such as spotlights, studio heaters, and other photography equipment. This system only works optimally on a 3-phase power grid. For household applications (single phase), modifications are required. Furthermore, there is no feature for measuring current, only voltage. Integration with IoT or Wi-Fi can be developed to allow remote monitoring of system status via an app or online dashboard.

Voltage testing is the process of comparing the results of a voltage sensor with a digital multimeter. The following are the results of the voltage measurement test:

**Table 1.** Voltage Measurement Test

Pengukuran		ErrorPersentase Error (%)	
Multimeter	Arduino		
218,2	218,4	0,2	0,10
227,7	227,9	0,2	0,10
229,2	220,12	0,92	0,44
228,7	228,8	0,1	0,05
228,6	229,2	0,6	0,29
227,4	227,97	0,57	0,27
228	227,92	0,08	0,04
227,5	227,54	0,04	0,02
229,2	228,4	0,8	0,38
229,3	228,83	0,47	0,22
228,9	227,54	1,36	0,65
227,8	227,54	0,26	0,13
226,4	226,68	0,28	0,14
226,5	227,11	0,61	0,30
227,1	228,4	1,3	0,63
227	227,97	0,97	0,47
Rata-rata		0,55	0,26

#### Current Measurement Testing

This test is conducted to ensure that the current sensor used is capable of accurately detecting electrical current according to the monitoring system's requirements. The primary purpose of the test is to verify the sensor's ability to read current and ensure that the obtained values are within acceptable tolerance limits. The following are the results of the

current measurement test:

**Table 2.** Current Measurement Testing

Pengukuran		ErrorPresentase	
Multimeter	Arduino		Error (%)
1,8	1,82	0,02	1,11
1,92	1,93	0,01	0,56
1,9	1,89	0,01	0,56
1,9	1,92	0,02	1,11
1,9	1,86	0,04	2,22
1,9	1,9	0	0
1,9	1,88	0,02	1,11
1,9	1,87	0,03	1,67
1,9	1,89	0,01	0,56
1,9	1,9	0	0
1,9	1,86	0,04	2,11
1,9	1,86	0,04	2,11
1,9	1,86	0,04	2,22
1,9	1,9	0	0,00
1,9	1,88	0,02	1,11
1,9	1,85	0,05	2,78
Rata - rata		0,02	1,20

The significant difference between the power readings on the measuring instrument and the monitoring media is caused by the low power factor value which affects the measurement accuracy.

### CONCLUSION

Based on the analysis and testing results, it can be concluded that the microcontroller-based phase failure detector system designed in this study is capable of detecting the loss of one of the phases (R, S, or T) in a three-phase electrical system effectively and responsively. The implementation of a voltage sensor as input to the microcontroller provides accurate results in reading phase conditions, so that the system can provide warnings via a buzzer and automatically disconnect the load via a relay. The test results show that the system is capable of responding in less than 1 second when a phase failure occurs, thus minimizing potential damage to photography studio equipment that is sensitive to power supply imbalances. The system also shows stable performance under various load and voltage variation conditions. With the success of the system in detecting and responding to phase failures, this tool can be used as an effective preventive solution in protecting electronic devices based on a three-phase power supply. In the future, further development can be carried out by integrating an Internet of Things (IoT)-based monitoring system to improve the function of remote monitoring and recording disturbance history in real-time.

## REFERENCE

- Arianto, Jefri. "Reliability Study of 20 KV Distribution System Based on GIS (Geographic Information System) Using RIA (Reliability Index Assessment) Method". Surabaya: 2015.
- Ashari, Avisena. "Types of Energy Changes and Examples of Energy Changes Around Us". Jakarta: 2021. Accessed on September 6, 2021. from: <https://bobo.grid.id/read/082561302/besar-cepat-besar-energi-dan-cepat-besar-energi-di-Around-kita?page=all>.
- Aryza, S., Irwanto, M., Lubis, Z., Siahaan, A.P.U., Rahim, R., & Furqan, M. (2018). A Novelty Design Of Minimization Of Electrical Losses In A Vector Controlled Induction Machine Drive. In IOP Conference Series: Materials Science and Engineering (Vol. 300, No. 1, p. 012067). IOP Publishing.
- Hajar, Ibnu et al., "Analysis of SAIDI SAIFI Value as an Index of Reliability of Electricity Provider at PT PLN (Persero) Power Feeder in Ciputat Area". Jakarta: 2018.
- Hamdani, H., Tharo, Z., & Anisah, S. (2019, May). Comparison of Solar Power Plant Performance Between Mountainous and Coastal Areas. In National Engineering Seminar (Semnastek) Uisu (Vol. 2, No. 1, pp. 190-195).
- PT PLN (Persero). 1983. SPLN No.52-3: System Security Pattern. Jakarta.
- PT PLN (Persero). 1985. SPLN NO.64: Fuse Cut Out Specifications. Jakarta.
- PT PLN (Persero). 1985. SPLN no. 59: Reliability of 20 KV and 6 KV Distribution Systems. Jakarta.
- PT PLN (Persero). 1986. SPLN NO.68-2: Level of Electric Power System Assurance. Part Two: Distribution Systems. Jakarta.
- Putri, M., Wibowo, P., Aryza, S., & Utama Siahaan, A.P. Russiadi.(2018). An implementation of a filter design passive Lc in reducing a current harmonics. International Journal of Civil Engineering and Technology, 9(7), 867-873.
- Putri, et al. "Analysis of 400 kVA Distribution Transformer Security with Fuse Cut Out", Medan, 2019.
- Rahmat, Gheschik Safiur, "Evaluation of Reliability Index of 20 KV Distribution Network System in Surabaya using Loop Restoration Scheme". Digilib ITS, Surabaya: 2013.
- Roger, C. Dugan. "Electrical Power Quality". Semarang: 2004. Muhammadiyah University of Semarang.
- Santoso, R. Nurhalim. "Evaluation of 20 KV Network Reliability Level at Bangkinang Substation Using FMEA (Failure Mode Effect Analysis) Method". Riau: 2016.
- Saadah, Siti. "Evaluation of the Reliability of Electric Power Distribution System Based on SAIDI and SAIFI". Yogyakarta: 2008. National Institute of Technology.
- Suhadi, et al. "Electric Power Distribution Techniques Volume 1". Directorate of Vocational High School Development. Jakarta: 2008.
- Suswanto, Daman. "Electric Power Distribution System". Padang: 2009. Faculty of Engineering, Padang State University.
- Bishri, M. A. A., Dalimunthe, M. E., & Lesmana, D. (2024). Analysis of Reactive Power Flow in an Electric Power System. *Fidelity: Jurnal Teknik Elektro*, 6(3), 198-203.

- Siagian, P., & Dalimunthe, M. E. (2023). LOW-SPEED WIND POTENTIAL FOR WIND POWER GENERATION. Tahta Media Publisher.
- Harefa, W. A., Aryza, S., & Dalimunthe, M. E. (2025). Analysis of Electric Power Usage Level and Total Electricity Consumption Duration at Binjai City. *INFOKUM*, 13(04), 1248-1257.
- Ginting, E., Fahreza, M., & Dalimunthe, M. E. (2024). ELECTRICAL SYSTEM ANALYSIS AT KUALA NAMU CENTRAL SERVICE LABORATORY. *Power Elektronik: Jurnal Orang Elektro*, 13(1), 52-57.