



## The Influence Of Online Customer Reviews, Online Customer Ratings and Price Consciousness on Purchasing Decisions in Shopee E-Commerce on Gen Z Sub-District Binawidya Pekanbaru City

**Ulin Nuha**

Sultan Syarif Kasim Riau State Islamic University, Pekanbaru, Indonesia

Email : [nuhauin060202@gmail.com](mailto:nuhauin060202@gmail.com)

**Ferizal Rachmad**

Sultan Syarif Kasim Riau State Islamic University, Pekanbaru, Indonesia

\*Email : [ferizal@uin-suska.ac.id](mailto:ferizal@uin-suska.ac.id)

### ARTICLE INFO :

#### **Keywords :**

Online Customer Review,  
Online Customer Rating,  
Price Consciousness,  
Purchasing Decisions

-----  
**Article History :**

Received :2024-07-26  
Revised : 2024-08-17  
Accepted :2024-09-29  
Online :2024-09-30

### ABSTRACT

*This research was conducted in gen z, Binawidya District, Pekanbaru City. The aim of this research is to analyze the influence of online customer reviews, online customer ratings and price consciousness on purchasing decisions in Shopee e-commerce in Gen Z, Binawidya District, Pekanbaru City. The data collection technique uses a questionnaire. The type used in this research is a quantitative type regarding the influence between variables. Research data was analyzed using SPSS version 24. The sample in this study was Gen Z, Binawidya District, Pekanbaru City, totaling 96 people using the purposive sampling method. Based on the results of this research, it shows that Online Customer Reviews, Online Customer Ratings and Price Consciousness influence purchasing decisions both partially and simultaneously. The results of the Coefficient of Determination ( $R^2$ ) show that the R square value is 0.770 or 70%, indicating that the variables Online Customer Review, Online Customer Rating and Price Consciousness as a whole have an influence of 70% on purchasing decisions. Meanwhile, the remaining 30% is influenced by line variables which were not examined in this research.*

### **INTRODUCTION**

The rapid development of technology today raises a new thought for business people, especially in overcoming the obstacles of space and time that have been a problem in conventional sales systems. In addition, the progress towards rapid innovation is very useful to fulfil their needs and way of life. In the current turn of technology, every part of the larger society consistently cannot be separated from the internet whether it is to communicate with others, search for data or others. One of the conveniences that can be felt is to make it easier for individuals to search for anything desired such as shopping. This technology is a new type of media that allows users to easily obtain data and use it in various needs, for example, sending messages, reading the desired data, sharing data, making work easier, even shopping online or without the need to come to the seller's place which we know as e-commerce.

One marketplace that is very popular now among teenagers to adults is Shopee. Shopee was officially announced in Indonesia in December 2015 under the auspices of PT Shopee International Indonesia. Since its launch, Shopee has experienced very rapid development, even in October 2017 the application has been downloaded more than 43 million times. Shopee arrived in the Indonesian market at the end of May 2015 and began operations in June 2015. Shopee is a subsidiary of Garena located in Singapore. The increasingly





widespread infiltration of props clients has made PT Shopee Internasional Indonesia see new opportunities opening up in the world of internet-based businesses. Currently Shopee has spread to various countries in the Southeast Asian region such as Singapore, Malaysia, Vietnam, Thailand, the Philippines, and Indonesia.

Based on SimilarWeb data, shopee is an e-commerce marketplace category that has the most site visits in Indonesia throughout 2023.



Figure 1. Marketplace mostvisits

Source : databoks.katadata.co.id

According to Banjarnahor et.al (2021), online customer reviews are information that is considered credible and trustworthy by companies to help consumers determine products. Online customer rating is a method for measuring customer satisfaction with a particular product or service through collecting feedback from customers online. Price consciousness is a purchasing decision that focuses on low prices. For consumers who have price awareness, consumers prioritise low prices in buying a product, apart from assessing the quality, low prices are also one of the considerations of consumers before buying. Generally, consumers will buy goods according to their needs and budget. According to Kotler and Keller, (2016) consumer purchasing decisions are purchasing decisions of individual end consumers and households who buy goods and services for personal consumers.

The most important thing about online customer reviews, online customer ratings and price consciousness is how credible and how far the strength of online customer reviews, online customer ratings and price consciousness can influence customer purchasing decisions. However, there are some disadvantages in shopping online, namely that you cannot directly see the condition of the goods being sold, so you cannot guarantee whether the item is suitable. The selection of Gen Z as the object of research in addition to the results of the pre-search above, namely with the background of Gen Z who likes to shop online. Generation Z or Gen Z is a generation born in the range of 1997 to 2012, this is the range of years used in Indonesia based on the 2020 population census data with an age range of 12 - 27 years which is assumed to have sufficient knowledge to judge that buying online by looking at online customer reviews, online customer ratings and price consciousness to decide to buy a product at Shopee e-commerce.

This study will analyse the effect of online customer reviews, online customer ratings and price consciousness on purchasing decisions at E-commerce Shopee for Gen Z in Binawidya District, Pekanbaru City. This is done because online customer reviews, online customer ratings and price consciousness are important





things, how credibility and the extent of the strength of online customer reviews, online customer ratings and price consciousness can influence customer purchasing decisions.

## LITERATURE RESEARCH

### A. Consumer Behaviour Theory

According to Schiffman and Kanuk (2010), consumer behaviour is defined as the behaviour shown by consumers in searching for, buying, using, evaluating, and spending products and services that are expected to satisfy needs. Consumer behaviour as the behaviour that consumers display in searching for, buying, using, evaluating, and disposing of products and services that they expect to satisfy their needs.

In terms of marketing strategy development, the dynamic nature of consumer behaviour implies that one should not expect that the same marketing strategy can deliver the same results across time, markets, industries. Consumer behaviour involves exchange. This is the last thing emphasised in the definition of consumer behaviour, which is the exchange between individuals. This keeps the definition of consumer behaviour consistent with the definition of marketing which has so far also emphasised exchange. In fact, the role of marketing is to create contention with consumers through the formulation and implementation of marketing strategies.

### B. Online Customer Review

According to Mo et al. (2015), Online Customer Review is a review provided by consumers related to information from evaluating a product about various aspects, with this information consumers can get the quality of the product they are looking for from reviews and experiences written by consumers who have purchased products from online sellers.

### C. Online Customer Rating

According to Agustina and Kurniawan (2018) Online Customer Rating is a certain rating scale in the form of a scale of the number of stars (usually 1-5 stars) made by consumers for products purchased online. Rating is one of the indicators for consumers in shaping the reputation of online shops in e-commerce.

### D. Price Consciousness

According to Konuk (2015), Price consciousness is the tendency of consumers to look for price differences. Price-conscious consumers are less concerned with product quality, they enjoy planning and shopping, when they shop they usually buy impulsively to switch brands and feel attracted to new products.

### F. Purchasing Decisions

Purchasing decisions are actions after the results of consumer analysis based on the information obtained, recognising problems and evaluating and comparing alternative options to decide to buy a product (Ilmiyah and Krishermawan, 2020). Purchasing decisions are often formulated on the basis of publicly available information such as product attributes that can be of interest, word of mouth, and encourage consumer purchasing decisions (Moe and Schweidel, 2011).

### G. Conceptual Framework

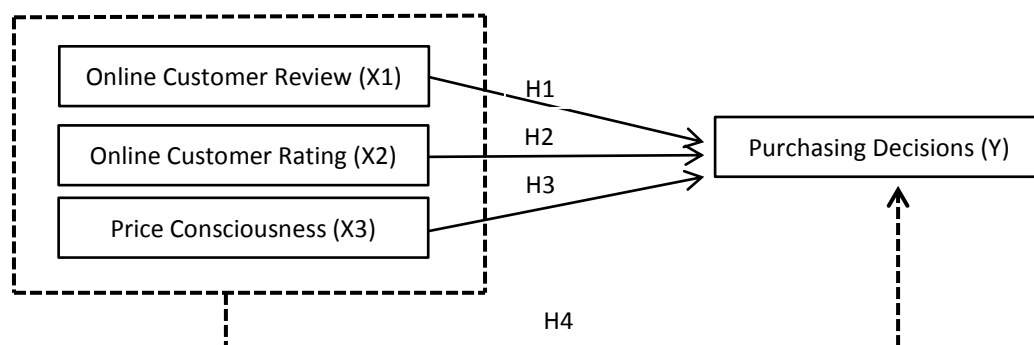

**Figure 2. Conceptual Framework**

Source : Research Data (2024)





## METHOD

### A. Population and Sampling Method

Population is a generalisation area consisting of objects or subjects that have certain qualities and characteristics set by researchers to study and then draw conclusions. The population in this study were all gen z in Binawidya sub-district, Pekanbaru city who used Shopee e-commerce. The sample size was taken using the Lemeshow formula. The Lemeshow formula is used because the population of gen z in Binawidya sub-district of Pekanbaru city who use shopee e-commerce is unknown. So that the number of calculations based on this formula is 96 people.

### B. Research Variables And Measurement

This research uses quantitative data. Quantitative data is data that refers to information that can be measured in numbers or numbers. Quantitative data provides the basis for statistical analysis, mathematical modelling and more systematic interpretation. According to Sanusi, (2011), as for the types and sources of data that will be the material for analysis in research, namely:

- a) Primary data is data that refers to information collected directly from the first source. The sources used in this study are responses obtained through questionnaires filled out by respondents who use Shopee e-commerce on Gen Z in Binawidya District, Pekanbaru City.
- b) Secondary data is information that has existed before and is not collected directly by researchers. Related to secondary data, researchers utilise this data according to their needs. In this data, secondary data is obtained by collecting journals, documents, books, reports, or scientific papers related to the influence of Online Customer Review, Online Customer Rating and Price Consciousness on purchasing decisions in shopee e-commerce on gen z in binawidya sub-district, pekanbaru city.

For testing in this research, used:

#### 1. Data Analysis Technique

##### a. Scaling up techniques

According to (Sugiyono: 2014) the Likert scale is used to measure the attitudes, opinions and perceptions of a person or group of people about social phenomena. The answer to each instrument that uses a Likert scale has gradations from very positive to very negative.

##### b. Descriptive Analysis

Descriptive analysis is a research method by collecting data in accordance with the actual then the data is arranged, processed and analysed to be able to provide an overview of the existing problems. In descriptive analysis, data is usually displayed in the form of ordinary tables or frequency tables, graphs, bar charts, line diagrams, pie charts, measures of data concentration, measures of data distribution and so on (Sugiyono, 2010).

#### 2. Data Quality Test

##### a. Validity Test

According to Sugiyono (2014) The validity test is a statistical test used to determine how valid a question item measures the variables being studied. A questionnaire is declared valid if the questions on the questionnaire are able to reveal something that will be measured by the questionnaire. By using the Corrected Item-Total method, the validity results can be found on all question items.

##### b. Reliability Test

The reliability test aims to show the consistency of a measuring device in collecting the same symptoms, each collecting tool should have the ability to provide consistent collecting results (Abdullah, 2015). The reliability test criterion is by looking at the Cronbach alpha ( $\alpha$ ) value for each variable. Cronbach alpha is used to determine the extent to which the items in the curriculum vitae are consistent. Where the variable vitae is proposed to be reliable if it provides a Cronbach alpha value  $> 0.60$ .





### 3. Classical Assumption Test

#### a. Normality Test

The normality test is intended to test whether the residual values that have been standardised in the regression model are normally distributed or not. Normally distributed standardised residual values if described by the shape of the curve will form a bell image whose two sides widen to infinity (Suliyanto: 2011). Normality tests can be done in various ways, one of which is the Kolmogorov Smirnov test. If the Asymptotic significant (2-tailed) value  $> 0.05$ , then the residual value is normally distributed, but if the Asymptotic significant (2-tailed) value  $< 0.05$  then the residual value is not normally distributed.

#### b. Multicollinearity Test

The multicollinearity test is carried out to determine whether there are symptoms of correlation between independent variables in the regression model. According to Ghazali (2018) the regression model can be declared good if there is no correlation between the independent variables. To find out whether there is multicollinearity in a regression model or not, the method that can be used is as follows: if the tolerance value  $> 0.1$  and the VIF value  $< 10$ , it can be concluded that there is no multicollinearity between the independent variables in the regression model.

#### c. Heteroscedasticity Test

Heteroscedasticity test is proposed to test whether in any regression model there is inequality of variance from one observation to another (Sahir, 2022). A regression model is said to have no heteroscedasticity if the scatterplot graph shows that there is no clear pattern, and the points spread above and below the number 0 on the Y axis. The heteroscedasticity test is seen from the Spearman Rank correlation coefficient value, if the probability value (sig)  $> 0.05$  then there is no heteroscedasticity.

#### d. Autocorrelation Test

According to Suliyanto (2011) the autocorrelation test aims to determine whether there is a correlation between members of a series of observational data broken down by time (time-series) or (cross section). A common method for testing autocorrelation is the Durbin-Watson test. The value of the Durbin-Watson statistic ranges between 0 and 4 which indicates the possibility of positive or negative autocorrelation, and a value close to 2 indicates that there is no autocorrelation.

### 4. Multiple Linear Regression

According to Situmorang, (2019) multiple linear regression is proposed to determine the linear relationship between several built-in variables commonly called  $X_1, X_2, X_3$  and the other built-in variables  $Y$ , the functional relationship between built-in variables and built-in variables is calculated as follows:

$$Y = a + b_1x_1 + b_2x_2 + b_3x_3 + e$$

### 5. Hypothesis Test

#### a. Partial Test (T Test)

The t test is used to evaluate whether one or more variables have a significant impact on the variable responses in the model. This test is carried out to measure the level of significance or the relationship of each independent variable to the dependent variable in the regression model, provided that it uses a significance level of 5% with a 2-sided test or 0.05 (Ghozali, 2018).

- If  $t \text{ count} > t \text{ table}$  or  $\text{sig} < \alpha$ , then :  
H<sub>0</sub> is rejected, H<sub>a</sub> is accepted, meaning that there is a partial effect between Online Customer Review, Online Customer Rating and Price Consciousness on purchasing decisions in shopee e-commerce in gen z sub-district binawidya pekanbaru city.
- If  $t \text{ count} < t \text{ table}$  or  $\text{sig} > \alpha$ , then :  
H<sub>0</sub> is accepted, H<sub>a</sub> is rejected, meaning that there is no partial influence between the variables of Online Customer Review, Online Customer Rating and Price Consciousness on the purchase decision in shopee e-commerce in gen z binawidya sub-district of pekanbaru city.





**Table 1. Partial Hypothesis Test Results (T Test)**

Coefficients <sup>a</sup>						
Model		Unstandardized Coefficients		Standardized Coefficients	T	Sig.
		B	Std. Error	Beta		
1	(Constant)	7,533	,895		8,420	,000
	Online customer review	,169	,057	,217	2,974	,004
	Online customer rating	,134	,092	,115	1,450	,150
	Price consciousness	,688	,074	,641	9,283	,000

a. Dependent Variable: Y1

Source: processed data in 2024

b. Simultaneous Test (F Test)

According to Ghozali (2018) the simultaneous test is used to determine whether the independent variables jointly affect the dependent variable. Testing can be done by comparing the Fcount value with Ftable at a significance level of 0.05. Adapun pelnguljiannya as berikut:

- If F count > F table or sig < α. Then :  
H0 is rejected, Ha is accepted, meaning that there is a simultaneous relationship between Online Customer Review, Online Customer Rating and Price Consciousness on purchasing decisions in shopee e-commerce in gen z sub-district binawidya city pekanbaru.
- If F count < F table or sig > α. Then :  
H0 is accepted, Ha is rejected, meaning that there is no simultaneous relationship between Online Customer Review, Online Customer Rating and Price Consciousness on the purchase decision in shopee e-commerce in gen z binawidya sub-district of pekanbaru city.

**Table 2. Simultaneous Test Results (F Test)**

ANOVA <sup>a</sup>						
Model		Sum of Squares	df	Mean Square	F	Sig.
1	Regression	338,493	3	112,831	35,656	,000 <sup>b</sup>
	Residual	291,132	92	3,164		
	Total	629,625	95			

a. Dependent Variable: Keputusan pembelian

b. Predictors: (Constant), Price consciousness, Online customer review, Online customer rating

Source: processed data in 2024

From the table it can be seen that the F test results know the Fcount value of 35.656 with a significance value of 0.000. The Fcount value will be compared with the Ftable value obtained from the statistical Ftable of 2.70. Thus it is known that Fcount (35.656) > Ftable (2.70) with a significance value (0.000) < 0.05. This means that simultaneously (together) Online Customer Review, Online Customer Rating and Price Consciousness have a significant influence on Purchasing Decisions at E-commerce Shopee for Gen Z in Binawidya District, Pekanbaru City.

c. Test Coefficient of Determination (R2)

The coefficient of determination is an estimate of how well the variability of the dependent variable can be explained by the independent variables in the correlation model. This provides information about how well the regression model fits the observed data. The coefficient of determination (R2) ranges between 0 and 1, where a higher value implies a better fit. The criteria for analysing the coefficient of determination are:

- If the coefficient of determination is close to zero (0), then the influence of the independent variable on the dependent variable is weak.
- If the coefficient of determination exceeds one (1), then the influence of the independent variable on the dependent variable is strong.





## RESULTS AND DISCUSSION

### 1. The Effect of Online Customer Review, Online Customer Rating and Price Consciousness on Purchasing Decisions

Based on the results of the F test, it is known that the Fcount value is 35.656 with a significance value of 0.000. The Fcount value will be compared with the Ftable value obtained from the statistical Ftable of 2.70. Thus it is known that Fcount (35.656) > Ftable (2.70) with a significance value (0.000) < 0.05. This means that simultaneously (together) Online Customer Review, Online Customer Rating and Price Consciousness have a significant influence on Purchasing Decisions at E-commerce Shopee for Gen Z in Binawidya District, Pekanbaru City.

## CONCLUSION

Based on the results of the research carried out, the following conclusions can be drawn:

1. Partially, Online Customer Reviews have a positive and significant effect on Purchasing Decisions on Shopee E-commerce in Gen Z, Binawidya District, Pekanbaru City.
2. Partially, Online Customer Rating has a positive but not significant effect on Purchasing Decisions on Shopee E-commerce in Gen Z, Binawidya District, Pekanbaru City.
3. Partially, Price Consciousness has a positive and significant effect on Purchasing Decisions on Shopee E-commerce in Gen Z, Binawidya District, Pekanbaru City.
4. Simultaneously, Online Customer Review, Online Customer Rating and Price Consciousness have an influence on purchasing decisions on Shopee e-commerce in Gen Z, Binawidya District, Pekanbaru City.
5. Based on the calculation of the Coefficient of Determination (R<sup>2</sup>), the R square value is 0.770 or 70%. This shows that the Online Customer Review, Online Customer Rating, and Price Consciousness variables have an influence of 70%, while the remaining 30% are other variables not examined in this research.

## BIBLIOGRAPHY

- Abdullah, M. (2015) *Quantitative Research Methodology*, Aswaja Pressindo. Sleman: Aswaja Pressindo.
- Agustina, L. and Kurniawan, F. (2018) "Seller Reputation System in the Purchase Decision Making Process on the C2C E-commerce Platform". *Indonelsia Communication Journal*, 7 (1).
- Almana, A.M. and Mirz, A.A. (2013) "The Impact of Electronic Word of Mouth on Consumers". *Purchasing Decisions*, *International Journal of Computer Applications*, 82(9), pp. 23-31.
- Arbaini, P., Wahab, Z. and Widayanti, M. (2020) "The Effect of Consumer Online Ratings and Reviews on Purchasing Decisions for Tokopedia Marketplace Users", *Journal of Business and Management*, 7(1), pp. 25-33.
- Ardianti, A.N. and Widiartanto, M.A. (2019) "The Effect of Online Customer Review and Online Customer Rating on Purchasing Decisions through the Shopee Marketplace.". *Journal of Business Administration Science*, pp. 1-11.

