

**TAX CONTROL FRAMEWORK, TAX RISK, AND TAX COMPLIANCE:
EVIDENCE FROM INDONESIAN LARGE TAXPAYERS**

By:

Gilang Kusumabangsa

*Faculty of Economics and Business
University of Indonesia, Jakarta, Indonesia*

Email:

gkusumabangsa@gmail.com

ABSTRACT

This research aims to examine the effect of the tax control framework (TCF) on internal control, tax risks, and tax compliance among large taxpayers in Indonesia. Currently, research in Indonesia still rarely explores TCF and tax risk. This research uses quantitative research methods with a Structured Equation Model (SEM) approach. Data collection was carried out using a questionnaire filled out by 502 respondents registered in the Large and Special Regional Tax Office and data analysis of tax audit results for the last 4 years. The research findings showed empirical evidence that TCF has a negative and significant effect on tax risk and tax audit results as a proxy for tax compliance. Apart from that, TCF also has a positive and significant effect on taxpayers' internal control.

Keywords: Indonesian Large Taxpayers, Tax Control Framework, Tax Risk, Tax Compliance, Structured Equation Model

A. INTRODUCTION

Tax compliance is a classic problem for many tax authorities, not least for the Directorate General of Taxes (DGT). The DGT pays special attention to tax compliance as outlined in the DGT's mission, which is to improve tax compliance through quality and standardized services, effective education and supervision, and fair law enforcement (Andreoni et al., 1998).

Various compliance strategies have been implemented to improve tax compliance performance in Indonesia. At the macro level, Indonesia's tax ratio over the last five years is still far below the standard of ASEAN countries at 15%.

In addition, the formal compliance indicator in the form of ratio for submitting the 2023 Annual Tax Return only reached 83%. This situation is still below the Organization of Economic Co-operation and Development (OECD, 2023) standard of 85%. More specifically, looking at the material compliance of Large and Special Taxpayers, namely the tax gap equalized with the value in the Taxpayer's Underpaid Tax Assessment Letter in the last three years, shows the following statistics:

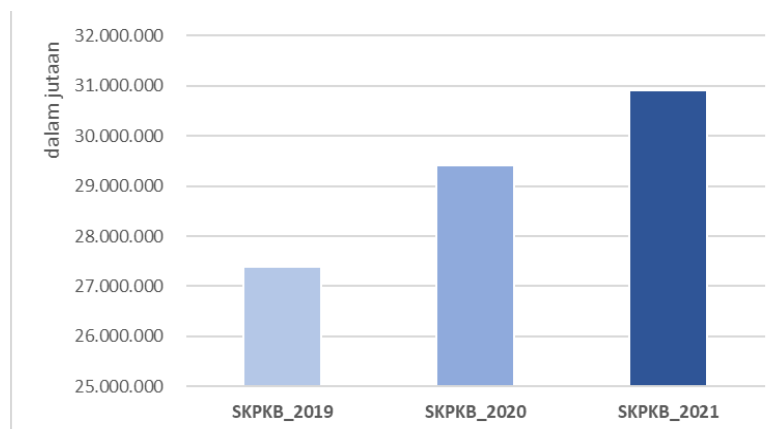

Source: Directorate General of Taxes

Figure 1.

Assessment Value of Underpaid Tax Assessment Letter for Large and Special Taxpayers in 2019-2022

The Taxpayer's Underpaid Tax Assessment Letter that tends to increase verifies that the tax returns prepared by taxpayers are not fully accurate and complete. Therefore, the DGT paradigm that has been focusing on the tax return acceptance and management stage needs to be complemented with a strategy at the tax return preparation stage in the taxpayer system.

One of the development areas at the tax return preparation stage is the Tax Control Framework (TCF). TCF is recommended by (OECD, 2016) as one of the strategies that can ensure sustainable tax compliance management. Based on previous research, TCF has been proven to improve the quality of tax returns, reduce the risk of fraud within taxpayers, and mitigate the impact of tax risks (ADB, 2022; Choi and Park, 2022; Siglé et al., 2022).

In a broader perspective, TCF is an integral part of the internal control system and corporate governance. Internationally, the principles of corporate governance are contained in a guidebook released by the OECD in 2015. In Indonesia, corporate governance principles have been adopted through the 2021 General Guidelines for Indonesian Corporate Governance issued by the National Committee on Governance Policy. These guidelines emphasize that the board of commissioners has the responsibility to proactively oversee tax risk management strategies by developing appropriate tax policy principles and establishing internal tax control systems. This is in line with the joint responsibility of the company's Board of Directors and Commissioners as per article 9 paragraph 2 of the Minister of Finance Regulation No. 61 of 2023.

Although many corporations in Indonesia have implemented the COSO Internal Audit Framework (2013). Unfortunately, the COSO Internal Audit Framework does not specifically state tax risk management. In fact, according to the Australian Taxation Office (2022) tax risk management should be included in the corporate governance section.

Internal control itself is regulated several times in tax regulations. Among them is Article 5 letter e of the Director General of Taxes Regulation Number PER-9/PJ/2010 concerning Audit Standards to Test Compliance with Fulfillment

of Tax Obligations which conveys the importance of considering internal control to determine the scope of the audit before conducting in-depth testing in the field. Through the company's internal control system, weaknesses in the implementation of company management can also be identified. In addition, point 2.5 of Circular Letter of the Director General of Taxes number SE-25/PJ.54/1988 concerning Matters to be Considered in Conducting Audit emphasizes that evidence generated by entities with strong internal control systems has higher validity than evidence generated by entities with weak internal control systems. However, both regulations have now been revoked. In fact, this is in line with Auditing Standard (SA) 300 by the Indonesian Institute of Certified Public Accountants (IAPI) which guides the planning of an audit of historical financial statements. A sufficient understanding of internal control must be obtained to plan the audit and determine the nature, timing, and scope of the tests to be performed. By starting the audit of the taxpayer's internal control system, it will produce quality tax audit results and the taxpayer's right to fair tax treatment can be realized.

DGT as the Indonesian tax authority needs to assist taxpayers in managing tax risks prudently. As it develops, there should be a broader vision of taxpayer obligations in TCF. Taxpayers are not only expected to fulfill tax compliance obligations but are expected to pay more attention to managing their tax risks. From the tax authority side, TCF can be taken into consideration in formulating the focus of tax audits. In the future, TCF will be very important in preparing the tax ecosystem in Indonesia to enter the era of transparency through Mandatory Disclosure Rules (MDR) like in the UK. MDR itself requires taxpayers to disclose aggressive tax planning. In addition, in best practice in various countries, TCF is treated as the main prerequisite in cooperative compliance program participation because it can illustrate taxpayer risk management that can complement Compliance Risk Management (CRM) data.

Based on a preliminary survey conducted on 220 taxpayers registered at the DGT Regional Office for Large Taxpayers, DGT Special Jakarta Regional Office, and KPP Madya throughout Indonesia, the data shows that 68.18% of taxpayers have tax functions combined with other divisions. 66.67% of taxpayers evaluate and discuss tax management in board meetings only 1-2 times a year. In fact, 83.64% of taxpayers still perform fiscal reconciliation manually or use Microsoft Excel. In fact, taxpayers need to build systems, reporting and sufficient resources in order to identify and manage potential risks of tax non-compliance (OECD, 2016).

The description above illustrates the importance of this research. With its novelty value, it can make a very significant contribution to science and practically. To the best of the author's knowledge, not many studies have explored TCF in Indonesia. This research can also answer the recommendations of OECD (2013) which emphasizes the importance of research needs and discussions on TCF.

B. LITERATURE STUDY

Tax Compliance

There is no tax regulation in Indonesia that explicitly defines taxpayer compliance. According to (Nurmantu, 2003), taxpayer compliance is a situation where taxpayers fulfill their tax obligations and exercise their taxation rights in accordance with the Law. (Nurmantu, 2003) classifies taxpayer compliance into formal and material compliance.

Material compliance is a condition where the taxpayer substantively fulfills all material tax provisions. IRS (2009) uses tax gap as the main proxy of material compliance level. The definition of tax gap is the difference between the potential (legal) revenue of the country and the actual revenue collected (Khwaja & Iyer, 2014). This is in line with the definition of tax gap according to the Ministry of Finance (2020). The definition is considered equivalent or equated to the amount of the Tax Underpaid Assessment Letter.

Tax Risk

There are previous studies that use several different conceptual definitions and proxies for tax risk. (Hutchens and Rego, 2015) define tax risk as all tax-related uncertainties surrounding a firm's transactions, operations, financial reporting decisions, and reputation. Furthermore, (Neuman et al., 2016) argue that tax risk arises from the interaction of economic risk and tax law uncertainty and define tax risk as the potential for an action or activity, or the failure to take an action or pursue an activity that will cause future tax outcomes to differ from expectations. They developed a tax risk proxy by creating a tax risk index consisting of transactional, operational, compliance, financial accounting, management, and reputation risk components. (Drake, 2019) also documents that greater tax risk moderates the positive valuation of tax avoidance.

Tax Control Framework (TCF)

The first recommendation of the OECD report Co-operative Compliance: A Framework-From Enhanced Relationship to Co-operative Compliance is to emphasize the importance of TCF. Therefore, there is a need for research and discussion on how this framework is assessed as well as additional guidance on what can be provided to taxpayers on the expectations of tax authorities. The TCF is an integral part of the internal control system relating to tax risk management. The importance of TCF lies in its ability to provide verifiable assurance that tax returns submitted by taxpayers are accurate and complete (OECD, 2016).

The (IRBM, 2022) identifies six essential principles of tax corporate governance that are consistent with OECD TCF, namely:

1. Tax Strategy, where the tax strategy should be clearly documented and the responsibility of the company's senior management.
2. Comprehensively applied, where TCF should be able to govern all company activities that may affect the tax position and ideally should be applied daily by management and business operations.

3. Responsibility sharing, where the company board is responsible for the design, implementation, and effectiveness of the company's TCF framework. The role of the corporate tax division and its responsibilities for TCF implementation should be clearly divided with appropriate resources.
4. Documented governance, which requires systems, rules and reporting that identify and manage potential risks of tax non-compliance. This governance process should be documented with adequate resources to periodically review the effectiveness of TCF implementation.
5. Testing, where compliance with TCF policies and processes should be the subject of regular monitoring, testing and maintenance.
6. Provide assurance, where TCF must be able to provide assurance to stakeholders, including external stakeholders such as tax authorities, that tax risks have been managed through appropriate controls and the resulting tax returns are complete, clear, and correct.

Meanwhile, (IRAS, 2022) defines tax risk management and control framework three levels which as Tax Governance Structure, Entity-Level Controls and Tax Reporting Controls.

Internal Control

The Committee of Sponsoring Organizations of the Treadway Commission (COSO) launched the Internal Control-Integrated Framework in 1992 to provide a comprehensive framework to help organizations assess, maintain, and improve their internal control systems. This standard is the first integrated internal control concept that is widely accepted and used by companies around the world. The COSO framework divides the definition of internal control into five (5) elements, namely the control environment, risk assessment, control activities, information and communication, and monitoring.

A company's internal control is closely related to the company's tax position. (Armstrong et al., 2021) find that the weakness in the client's internal controls is positively associated with a company's tax risk. (Blouin et al., 2015) argue that well-governed firms are more likely to have internal control mechanisms to prevent tax avoidance.

Hypothesis Development

Empirically, (Choi and Park's, 2022) research also show that the better the corporate governance, the better the supervision and control of managers, so that it can mitigate the impact of tax risks in the future.

This is in line with OECD (2016) guidance, which expects internal tax control frameworks to also improve a company's ability to identify potential tax risks and prevent these risks from occurring. If tax risks do occur, the internal tax control framework should include monitoring mechanisms that detect and correct such errors.

However, some previous research findings show the opposite result. (Parker and Gilad, 2011), Gallemore and Labro (2015), Bauer (2016), and Chen et al. (2020) provide empirical evidence finding that internal control quality can be used

to manage risk and strengthen taxpayers' negotiating position when non-compliance is detected.

Based on the description of the research findings above, it is interesting to test the hypothesis of the relationship between TCF and tax risk on taxpayers in Indonesia. The first hypothesis in this study is as follows.

H₁: The better the tax control framework, the lower the tax risk.

Better TCF quality can contribute to improved compliance, both directly and indirectly through increased transparency (OECD, 2013; 2016). By helping to prevent unintentional non-compliance, improving the quality of internal tax controls can also directly support corporate tax compliance (OECD, 2014).

In previous research, (Siglé et al., 2022) documented that the better the quality of TCF, the better the level of transparency and compliance. In the study, compliance was measured by the number of tax audit adjustments. The research results of (Larsen et al., 2018) show that improving the quality of internal tax controls is how taxpayers can improve their tax compliance. However, some studies argue that internal control systems do not necessarily contribute to increased compliance (Gunningham & Sinclair, 2009; Parker & Gilad, 2011).

The differences in the findings of the above studies will be tested in the context of taxpayers in Indonesia with the following hypothesis:

H₂: The better the tax control framework, the lower the tax gap.

The Big 4 accounting firms recommend using the Internal Control-Integrated Framework created by COSO (1992, 2013) as the framework used to reduce uncertainty in tax management (PricewaterhouseCoopers, 2004; EY, 2014). The Australian Taxation Office (2013) also adopted COSO's Internal Control-Integrated Framework as an element used in assessing the TCF implemented by Australian Large Taxpayers. This means that it can be hypothesized that the better TCF is implemented by taxpayers, the better the maturity and effectiveness of their internal control.

H₃: The better the tax control framework, the better the internal control.

C. RESEARCH METHOD

The study tested the hypothesis using quantitative data analyzed using Structural Equation Modeling (SEM). The data collected is primary data using a questionnaire instrument. The questions in the questionnaire were organized into three sections. The first section aims to describe the level of TCF maturity of taxpayers. This section contains categorical data on the dimensions of TCF variables in accordance with the six essential principles of the OECD (2016), namely tax strategy (ts), comprehensively implemented (c), division of responsibilities (r), documented governance (d), testing (t) and provision of assurance (a).

The next section is the tax risk variable (TR) which contains questions with reference to the research of (Hutchens and Rego, 2015) and (Neuman et al., 2016). The tax risk proxy is compiled based on the taxpayer's risk appetite for financial,

operational, compliance, and reputation risk components which will then become the tax risk index.

The last section is useful for capturing taxpayers' perceptions of taxpayer internal control (IC) using a 6-point Likert scale on the five elements of the COSO Internal Control-Integrated Framework, namely the control environment, risk assessment, control activities, information and communication, and monitoring. The questionnaire was made in the form of a google form and distributed to taxpayers through the Directorate General of Taxes email blast.

The taxpayer compliance variable (LogSKPKB) is defined using tax gap data. Tax gap is the comparison data of the average value of Tax Underpaid Letter issued to business circulation for the last 4 years. The ratio is then normalized using log. This is in line with the definition of the IRS (2009) and the Ministry of Finance (2020), which agree to use the tax gap as the main proxy of the material compliance level equivalent to the Tax Underpaid Letter value. The Tax Underpaid Letter data is obtained through secondary data from the Directorate General of Taxes. Based on previous research developed in the hypothesis, the model built in the research in Structural Equation Modeling (SEM) analysis is as follows:

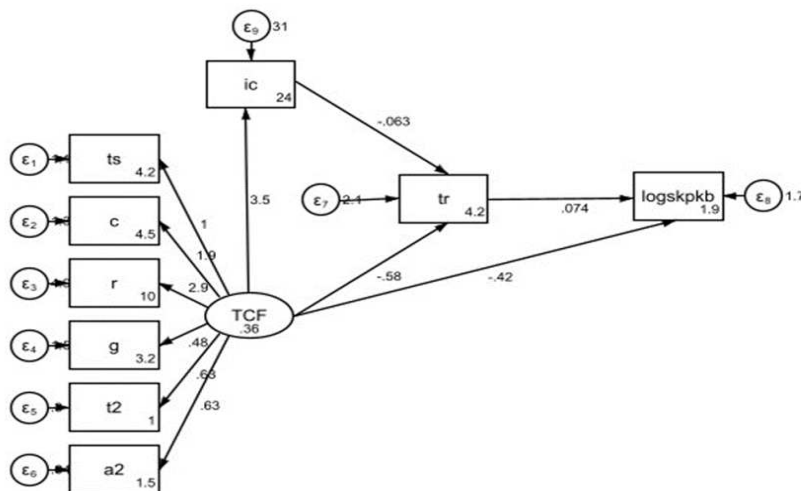

Source: Data Processed

Figure 2.

Research Model of Tax Control Framework, Tax Risk and Tax Compliance

The sampling method applied in the study is non-probability sampling with sampling techniques based on considerations predetermined by the author (purposive sampling). The sample taken is taxpayers registered in the Regional Office of DGT Large Taxpayers and the Regional Office of DGT Special Taxpayers with a population of 6,692 taxpayers. This is based on the best practice of tax governance implementation in Australia which focuses on the largest taxpayer as the determinant of state revenue.

D. RESULTS AND DISCUSSION

The questionnaire was distributed to 6,692 taxpayer emails registered in the Regional Office of DGT Large Taxpayers and the Regional Office of DGT Special Taxpayers. Based on the results of data processing, there were 6,010 emails that were successfully sent and 502 taxpayers who filled out the questionnaire completely to be processed and analyzed in this study.

Based on the questionnaire data, it was found that 351 taxpayers (70%) in Indonesia are aware of TCF even though it has never been regulated or introduced by DGT. Even 74 respondent taxpayers have implemented TCF with the justification that TCF can build tax governance, manage tax risks, and maintain reputation.

Next, the data from the questionnaire is tested for validity and reliability. The variables to be tested consist of endogenous variables as observed variables and exogenous variables as latent variables. Validity is tested using the Pearson Product Moment (PPM) method. The results of the PPM calculation are in the form of a correlation coefficient which is used to measure the validity level of an item and to determine the feasibility of an item for use. Items are said to be valid if $r_{count} > r_{table}$. While the reliability test uses Cronbach's Alpha where the coefficient value is said to be reliable when it is above 0.700.

After being tested using the STATA 17 application, there were 2 invalid question items, namely T1 and A1, so they were not eligible for further processing. After the two items were removed, the validity test results showed that all items used in the questionnaire had a correlation above 0.2787 (r_{table} with $n = 502$) which is the minimum limit of the validity test, and it can be concluded that all items are valid. In addition, based on Table 1 shows that all alpha values exceed 0.700 so that all items are concluded to be reliable.

Table 1.
Validity and Reliability Test Results

	Correlation Effect	Item-test Correlation	Alpha Value
IC ₁	+	0,8169	0,7943
IC ₂	+	0,8099	0,7951
IC ₃	+	0,8089	0,7954
IC ₄	+	0,7957	0,7978
IC ₅	+	0,8173	0,7948
TR	-	0,5112	0,8239
TS	+	0,3258	0,8332
C	+	0,5690	0,8186
R	+	0,7030	0,8370
G	+	0,3819	0,8301
T ₂	+	0,4032	0,8260
A ₂	+	0,3721	0,8274

Source: data proceed, 2024

The next step is to test the goodness of fit of the model based on theory with sample data as follows:

Table 2.
Goodness of Fit Test Results

	Statistical Results	Reference Value
<i>Chi Square</i>	0,000	The smaller the model, the better the fit between theory and sample data.
<i>Root Mean Square Error of Approximation (RMSEA)</i>	0,088	A value equal to or smaller than 0.08 is good enough.
<i>Tucker Lewis Index (TLI)</i>	0,780	Values close to 1 indicate a very high model fit.
<i>Comparative Fit Index (CFI)</i>	0,847	Values close to 1 indicate a very high model fit.
<i>Root Mean Square Residual (RMR)</i>	0,065	A good model fit has an RMR value of <0.05.

Source: data proceed, 2024

After the model meets the fit index reference as presented in Table 2, then the model is estimated for its causal effect using the STATA 17 application with the following results:

Table 3.
SEM Estimation Results

	Coefficient	p> z
TCF to TR	-0,580996	0,000
TCF against logSKPKB	-0,4150167	0,001
TCF against IC	3,495015	0,000
IC to TR	-0,0634956	0,000

Source: data proceed, 2024

Based on Table 3, empirical evidence is obtained that the implementation of TCF can increase tax compliance by reducing the tax assessment value by 0,4 times. In addition, TCF also simultaneously strengthens the internal control (IC) of taxpayers by 3,5 times. By implementing TCF, companies can manage and mitigate tax risk (TR) lower to a decrease of 0.5 times or almost 10 times compared to internal control (IC) with the Internal Control-Integrated Framework (-0,06).

The Effect of Tax Control Framework (TCF) on Tax Risk (TR)

The TCF variable (TCF) has a negative and significant effect on tax risk (tr). This finding proves empirically that the better the TCF owned by taxpayers, the smaller the tax risk faced by taxpayers.

This finding is in line with (Choi and Park's, 2022) research and the OECD's (2016) recommendations which show that TCF assists taxpayers in identifying potential tax risks and mitigating these risks from occurring. If tax risks do occur, TCF has included monitoring mechanisms that detect and mitigate the impact of such risks.

Through the implementation of TCF, compliance risk decreases as the quality of data and tax return reporting improves. In the long run, this will minimize financial risks in the form of administrative sanctions and tax audits.

Taxpayers who implement TCF will have a higher reputation and stakeholder trust because tax risks have been managed through appropriate controls. In addition, the board of directors will be more aware of and understand tax issues that have a major impact on the company's business risks and opportunities.

The Effect of Tax Control Framework (TCF) on Tax Compliance (Tax Gap)

The TCF variable (tcf) has a negative and significant effect on the value of Tax Underpaid Assessment Letter (logSKPKB). This finding is evidence that the better the TCF owned by the taxpayer, the better the taxpayer's material compliance as measured by the low value of the tax audit assessment.

This finding is consistent with the arguments of OEDC (2013; 2016), (Siglé et al., 2022) and (Larsen et al., 2018) which state that TCF directly supports tax compliance through its verifiable guarantee that tax returns submitted by taxpayers are complete, clear and correct. In addition, TCF is also able to prevent unintentional non-compliance and increase taxpayer transparency.

More deeply, the principle that has the most positive and significant effect on taxpayers' TCF is the principle of responsibility sharing (r). This means that taxpayers can clearly divide the roles and responsibilities of the tax division with the right resources.

However, there are several critical points of research findings that indicate that there is no seriousness of the company in managing resources in the taxation function, namely:

1. As many as 96,01% of respondents only have 10 employees in the corporate tax department and as many as 48,4% of respondents do not use tax consultant services in carrying out their tax rights and obligations. In fact, the workload of the corporate tax division is quite large because it manages many business units and even other affiliated companies.
2. 42% of respondents have not developed a formal document related to tax strategy or management.
3. A total of 41% of respondents have not developed an internal policy regarding the limits of significant transactions that require special authorization or escalation to external consultants.
4. As many as 85% of respondents organize training on tax topics only 1-5 times a year, either inhouse or outsourced, which causes employees who manage taxes to not have adequate tax competencies.
5. As many as 84% of respondents have taxation functions that are combined with other divisions. This causes a potential compliance risk and a large

operational risk because officers who manage taxes are not focused on carrying out their taxation functions.

6. Only 12% of respondents have the position of Vice President of Tax. In fact, the high number of tax-specific positions in the company structure represents how serious the taxpayer is in managing tax issues strategically.
7. As many as 90% of respondents perform fiscal reconciliation using only work papers in Microsoft Excel. The lack of automation in filling out fiscal reconciliation has the potential to reduce accuracy in the preparation of tax returns.

The aspects of TCF above need to be given special attention by the board of directors because they greatly affect the company's compliance in carrying out its tax obligations.

The Effect of Tax Control Framework (TCF) on Internal Control (IC)

The TCF variable (TCF) has a positive and significant effect on the company's internal control (ic). This finding strengthens the hypothesis that the better TCF is implemented by taxpayers, the better the maturity and effectiveness of their internal control.

The justification is that the TCF principles developed by the OECD are derived from the principles of COSO's Internal Control-Integrated Framework so that implementing TCF directly contributes to strengthening the overall internal control of taxpayers. Through the implementation of TCF, tax risks are managed through appropriate controls to provide assurance in the form of in control statements of corporate taxation to management and stakeholders.

E. CONCLUSIONS

This study aims to examine the effect of tax control framework (TCF) on internal control, tax risk and tax compliance at large taxpayers in Indonesia. Currently, research in Indonesia still rarely explores TCF and tax risk. This study uses quantitative research methods with a Structured Equation Model (SEM) approach. Data collection was carried out using a questionnaire filled out by 502 respondents registered with the Regional Office of the DGT of Large and Special Taxpayers and data analysis of tax audit results for the last 4 years.

The research findings show the following empirical evidence:

1. The TCF variable (TCF) has a negative and significant effect on tax risk (tr). This finding proves empirically that the better the TCF owned by taxpayers, the smaller the tax risk faced by taxpayers.
2. The TCF variable (TCF) has a negative and significant effect on the value of tax assessment (logSKPKB). This finding is evidence that the better the TCF owned by the taxpayer, the better the taxpayer's material compliance as measured by the low value of the tax audit assessment.
3. TCF variable (TCF) has a positive and significant effect on internal control (ic). This finding strengthens the hypothesis that the better TCF is implemented by taxpayers, the better the maturity and effectiveness of internal control.

This research has theoretical implications, namely novelty value and

significant contribution to science by enriching the discourse on TCF and tax risk as recommended by OECD (2013). Practically, this research provides recommendations to DGT as a tax authority to consider issuing regulations on TCF as best practice in other countries.

The limitation in this study is that the TCF data used based on the questionnaire is only able to describe its existence but has not measured its effectiveness. In addition, the distribution of questionnaires sent through the @pajak.go.id email domain may cause taxpayers to be biased in filling out the questionnaire.

REFERENCES

- Andreoni, J., Erard, B., Feinstein, J., Andreoni, J., & Feinstein, J. (1998). Tax Compliance. *Journal of Economics Literature*, 36(2), 818-860. <https://www.jstor.org/stable/2565123>
- Armstrong, C. Abernathy, J. L., Finley, A. R., Rapley, E. T., & Stekelberg, J. (2021). External Auditor Responses to Tax Risk. *Journal of Accounting, Auditing and Finance*, 36(3), 489-516. <https://doi.org/10.1177/0148558X19867821>
- Asian Development Bank. (2022). *Launching a Digital Tax Administration Transformation: What You Need to Know*. Philippines
- Bauer, A. M. (2016). Tax Avoidance and the Implications of Weak Internal Controls. *Contemporary Accounting Research*, 33(2), 449-486. <https://doi.org/10.1111/1911-3846.12151>
- Chen, H., Yang, D., Zhang, X., & Zhou, N. (2020). The moderating role of internal control in tax avoidance: evidence from a COSO-Based internal control index in China. *Journal of the American Taxation Association*, 42(1), 23-55. <https://doi.org/10.2308/atax-52408>
- Choi, J., & Park, H. (2022). Tax Avoidance, Tax Risk, and Corporate Governance: Evidence from Korea. *Sustainability (Switzerland)*, 14(1). <https://doi.org/10.3390/su14010469>
- Drake, K. D., Lusch, S. J., & Stekelberg, J. (2019). Does Tax Risk Affect Investor Valuation of Tax Avoidance? *Journal of Accounting, Auditing and Finance*, 34(1), 151-176. <https://doi.org/10.1177/0148558X17692674>
- Gallemore, J., & Labro, E. (2015). The importance of the internal information environment for tax avoidance. *Journal of Accounting and Economics*, 60(1), 149-167. <https://doi.org/10.1016/j.jacceco.2014.09.005>
- Gunningham, N., & Sinclair, D. (2009). Organizational Trust and the Limits of Management-Based Regulation. *Law and Society Review*, 43(4), 865-900. <https://doi.org/10.1111/j.1540-5893.2009.00391.x>
- Hutchens, M., & Rego, S. O. (2015). Does Greater Tax Risk Lead to Increased Firm Risk? *Ssrn*. <https://doi.org/10.2139/ssrn.2186564>
- Inland Revenue Board of Malaysia (IRBM) (2022). *Guidelines: Tax Corporate Governance Framework*.
https://phl.hasil.gov.my/pdf/pdfam/Guidelines_Tax_Corporate_Governance_Framework_2.pdf
- Inland Revenue Authority of Singapore (IRAS) (2022). *IRAS e-tax guide tax risk management and control framework for corporate income tax*.
https://www.iras.gov.sg/media/docs/default-source/e-tax/e-tax-guide_tax-risk-management-and-control-framework-for-corporate-income-tax.pdf?sfvrsn=aa3252c7_6

- Khwaja, M. S., & Iyer, I. (2014). Revenue Potential, Tax Space, and Tax Gap: A Comparative Analysis. World Bank Policy Research Working Paper, May.
- Larsen, L. B., Boll, K., Brögger, B., Kettunen, J., Potka-Soininen, T., Pellinen, J., Johansen, M. B., & Aziz, K. (2018). Nordic experiences of co-operative compliance programs: Comparisons and Recommendations (Issue October 2018).
- Neuman, S.S., Omer, T.C. and Schmidt, A.P. (2020). Assessing tax risk: Practitioner perspectives. *Contemporary Accounting Research*, 37, 1788-1827.
- Nurmantu, S. (2003). Pengantar Perpajakan. Yayasan Obor Indonesia.
- OECD (2011), OECD Guidelines for Multinational Enterprises, OECD Publishing, Paris. <http://dx.doi.org/10.1787/9789264115415-en>
- OECD (2013). Co-operative compliance: A framework: From enhanced relationship to co-operative compliance. OECD Publishing, Paris.
- OECD (2016). Co-operative tax compliance: Building better tax control frameworks, OECD Publishing, Paris.
- OECD (2023), Tax Administration 2023: Comparative Information on OECD and other Advanced and Emerging Economies, OECD Publishing, Paris. <https://doi.org/10.1787/900b6382-en>.
- Parker, C., & Gilad, S. (2011). Internal corporate compliance management systems: Structure, culture and agency. *Explaining Compliance: Business Responses to Regulation*, March, 170-195. <https://doi.org/10.4337/9780857938732.00014>
- Siglé, M. A., Goslinga, S., Speklé, R. F., & van der Hel, L. E. C. J. M. (2022). The cooperative approach to corporate tax compliance: An empirical assessment. *Journal of International Accounting, Auditing and Taxation*, 46, 1-20. <https://doi.org/10.1016/j.intaccudtax.2022.100447>
- S. Blouin, J.L. Jagolinzer, A.D. Larcker, D.F. (2015). Corporate governance, incentives, and tax avoidance. *J. Account. Econ.*, 60, 1-1