



# Implementation of A\* (A Star) Pathfinding Algorithm in 3D Isometric Projection Game “Survival Horror: Rabies Outbreak”

**Ita Arfyanti**   
Information Systems,  
STMIK Widya Cipta Dharma,  
Samarinda, 75123, Indonesia  
ita@wicida.ac.id

**Muhammad Ibnu Saad** \*  
Informatic Engineering,  
STMIK Widya Cipta Dharma,  
Samarinda, 75123, Indonesia  
saad@wicida.ac.id  
\*Corresponding author

**Leonardo**  
Informatic Engineering,  
STMIK Widya Cipta Dharma,  
Samarinda, 75123, Indonesia  
2043106@wicida.ac.id

 Submitted: 2025-02-27; Accepted: 2025-03-09; Published: 2025-03-15

**Abstract**—Rabies remains a lethal zoonotic disease, claiming over 60,000 lives annually. Despite medical advancements, inadequate treatment and lack of awareness contribute to persistently high mortality rates. To enhance public education and engagement in rabies prevention, this study develops an educational game, “Survival Horror: Rabies Outbreak.” The game integrates a 3D isometric survival horror experience with real-world information on rabies transmission, prevention, and emergency responses. Players assume the role of a police officer delivering anti-rabies vaccines to infected residents while evading aggressive rabid animals. The game employs the A\* (A Star) Pathfinding algorithm to enhance enemy AI, allowing dynamic and optimized pursuit behavior, thereby increasing realism and challenge. Beta testing with 10 respondents demonstrated that 60% of users rated the game positively, confirming its effectiveness as both an educational tool and an engaging survival-horror experience. The integration of AI-driven pathfinding with gamified learning provides a novel approach to public health education, offering an immersive method for raising awareness and fostering initiative-taking rabies prevention measures.

**Keywords**— Rabies Education, Serious Games, A\* Algorithm, Pathfinding, Gamification, AI in Games

## I. INTRODUCTION

According to Nadeem and Panda 2020, rabies is a fatal disease accounting for at least 60,000 deaths per year (Nadeem & Panda 2020). Palliative or aggressive approaches are required for suspected or confirmed rabies patients. However, most cases are not treated with the hospital mindset that the disease has a 100% mortality rate. Over time, some doctors have tried interventions to make them survive. As a result, there are few well-documented rabies survivors to date. Before 2004, only five cases survived who received incomplete PEP (Post-Exposure Prophylaxis) (Tarantola, Tejiokem & Briggs 2019). Ideally, PEP of a vaccination program should be started immediately after an animal bite immediately after

washing all wounds with soap and water, so that the viral load can be reduced at the inoculation site. The most common causes of PEP failure are 1 underuse of rabies immunoglobulin, 2 not all wounds were injected with immunoglobulin, 3 delay in prophylaxis by 6 days, 4 suturing of wounds before immunoglobulin injection, and 5 wounds in highly innervated areas of the body such as the face and hands. The reasons for PEP failure are due to all of the six points above.

Education about the dangers of rabies virus in adolescents needs to be done by parents to adolescents from an early age about animals that are at high risk of transmitting rabies are wild animals or pets that have not received rabies vaccines, infected animals can transmit the rabies virus through saliva, bites, or scratches and licks on the skin of a person who is injured. However, educating teenagers about the rabies virus is not an easy matter, starting from providing an understanding of what the rabies virus is, examples of animals infected with rabies, prevention of the rabies virus, and first aid for victims bitten by animals infected with rabies as recommended by health workers and the World Health Organization (WHO) but still does not provide effective information to teenagers (Crowcroft & Thampi 2015).

Survival horror is a genre where people commonly choose to escape from world happiness. Survival horror games offer endless tension, while continuing to encourage players to find a way to survive and survive until the end of the game. In accordance with its side genre, namely survival, it is made with the addition of educational elements, with the existence of educational games that are made, it will make it easier for teenagers to understand an information message given with interesting excitement.

The game designed is a game entitled "Survival Horror: Rabies Outbreak". To create an educational game, it will be designed to provide an understanding of how to avoid transmission and what actions to take if bitten by an animal suspected of being infected with rabies, the A\* algorithm is programmed to guide the enemy to chase the player by finding the shortest path to the player's location and taking the right action to hunt and then attack (Suyanto & Sc 2007).

The presence of this game includes interactive elements such as additional information about rabies, how it is transmitted, and preventive measures that can be taken, teenagers as the target players gain knowledge about the dangers of rabies and provide players with practical skills to deal with situations that may occur in real life when bitten by an animal infected with the rabies virus. The solution to preventing the rabies virus and the benefits offered by the educational game created will generate thinking in the community about the dangers of the rabies virus plus awareness of the importance of preventing the rabies virus by vaccinating beloved pets (Preiss et al. 2018; Kessels et al. 2019).

This game tells the story of a police officer who is on duty to deliver serum and rabies vaccine to the homes of residents who have been bitten by rabies animals. To make the game more interesting and not boring to play by the player, the player is made to use an anti-rabies vaccination syringe to fight the virus that infects animals that will later chase the player at any time, then the player must shoot the anti-rabies vaccination syringe into the infected animal, the player is challenged to survive and avoid attacks from infected animals in the city. the player has a mission to provide an objective, namely serum and rabies vaccine. in addition, the player also gets a weapon to help the player survive until he succeeds in delivering all the objectives to complete the game (Hocking 2022).

## II. METHODS

### A. Multimedia Development Life Cycle

MDLC is a method that aims to design and develop an application that combines video, images, audio, animation, and others. The MDLC method has 6 stages, including concept, design, material collecting, assembly, testing, and distribution. The six stages do not have to be sequential in practice, each stage can change positions. Although the conceptualization stage must be the first thing to do. The stages of the Multimedia Development Life Cycle (MDLC) method are as follows in Figure 1.

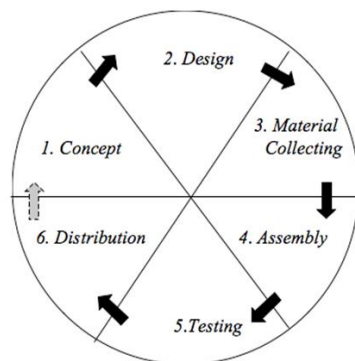

Figure 1. MDLC development stages

1. Concept is the stage to determine the purpose and users of the application. In addition, at this stage will also determine the type of application (presentation, interactive, etc.). The purpose of the end user of the program affects the nuances of multimedia reflection

of the identity of the organization that wants information to reach the end user. User characteristics, including user capabilities, also need to be considered because they can affect the design. The basic rules in application design are determined at this stage, for example the target platform, application size and others. The output of this stage is usually a narrative document to express the project objectives to be achieved.

2. Design is the stage of making specifications regarding the program architecture, style, appearance, and material or material needs that will be used in making the application. At this stage they usually describe the flow of each scene to describe the flow from one scene to another. Specifications are made as detailed as possible so that in the next stage, namely material collecting and assembly, new decision making is no longer necessary, it is enough to use the decisions that have been determined at this stage. However, in practice, project work in the initial stages will still often experience the addition of materials or reduction of application parts or other changes.
3. Material Collecting is the stage of collecting materials that are in accordance with the needs used. These materials include images, photos, animations, videos, audio, and texts, both ready-made and those that still need to be modified according to existing needs. These materials can be obtained for free, made by yourself or purchased from sites that provide files that will be used in making game applications. This stage can be done in parallel with the assembly stage. However, in some cases, the material collecting stage and the assembly stage will be done linearly and not in parallel.
4. Assembly is the stage of making the entire game application. The application to be made is based on the design stage. This stage usually uses software according to needs.
5. Testing, this stage aims to ensure that the application being developed is free from errors. In this study, the application will be assessed to users by asking questions about the game that has been built and information related to the application. The test results are filled in after the user plays the game.
6. Distribution This stage is the last stage in the multimedia application development cycle. Distribution can be done after the application is declared fit for use. At this stage it can also be called the stage for evaluation for the development of finished products so that the product becomes better than before.

### B. A\* (A star) algorithm

The A\* algorithm is designed to find a path from one point to another (Lambora, Gupta & Chopra 2019). Using the concept of a graph where there is a collection of nodes, which represent the origin, destination, and area for searching, and edges, which represent the connecting path between nodes (Russell & Norvig 2016; Permana et al. 2018). The path search process begins by receiving input

in the form of an origin node and a destination node after which a route search is carried out with the A\* algorithm (Hill 2016; Ju, Luo & Yan 2020). The resulting output has two possibilities, namely whether there is a route or is no route from the origin node to the destination node. The A\* (A Star) algorithm is a Best First Search algorithm that combines Uniform Cost Search and Greedy Best-First Search. The calculated cost is obtained from the actual cost plus the estimated cost. With this cost calculation, the A\* (A Star) algorithm can be optimal and complete in determining the path. Like the basic Best First Search algorithm, the A\* (A Star) algorithm also uses two lists: OPEN and CLOSED. There are three conditions for each successor that is raised, namely: already in OPEN, already in CLOSED, and neither in OPEN nor CLOSED. In these three conditions, different treatments are given.

### C. Pathfinding

Pathfinding or path finding in computer games has been researched for years. Pathfinding in commercial computer games must be completed in real-time, the path finding can be done with an algorithm (Suyanto & Sc 2007; Permana et al. 2018; Pardede et al. 2022).

### D. White Box Testing

White Box Testing is a software testing method where the internal structure is known to test who will test the software (Shaykhian 2007). This test requires internal knowledge of system and programming capabilities.

The number of test paths or paths that can be taken is called cyclomatic complexity which can be found using the formula (1)

$$V(G) = E - N + 2 \quad (1)$$

Description (1)

V(G) = Cyclomatic complexity  
E = Number of flow graph edges  
N = Number of flow graph nodes

### E. Beta Testing

Beta testing is a test conducted on one or more customers by the end user of the software. Unlike alpha testing, developers are usually not present so beta testing is a "live" application of the software in an environment that cannot be controlled by the developer. Customers record all problems (real or imaginary) they encounter during beta testing and report them to the developer at regular intervals (Fine 2002; Hai-Jew & Hai-Jew 2019). The Percentage Formula used is as follows (2)

$$Y = P / Q * 100\% \quad (2)$$

Description (2)

Y = Percentage Value  
P = Number of Answers  
Q = Number of Respondents

## III. RESULTS AND DISCUSSION

The result that can be obtained from this research is the creation of a Survival Horror Game: Rabies Outbreak packaged into an application that can be played on the Windows 10 platform and above. The stages in creating this application start from the first stage (concept) to the last stage (distribution), and will be explained as follows:

### A. Concept

A concept is needed, namely regarding the stages of the game such as the purpose of the game, game identification, general specifications of the game, game size and type of game. Where this concept will be made into a game with the genre Survival Horror game. In this stage, four things are taken that will be used as a concept in building "Survival Horror: Rabies Outbreak", namely.

1. Purpose of the game  
Contains an explanation of the purpose of building "Survival Horror: Rabies Outbreak" which defines the scope related to the limitations of the game's functions.
2. Type of game  
Contains an explanation of the type of Survival Horror game: Rabies Outbreak which explains what players can do when playing this game.
3. Identification of game users  
Contains an explanation of the identification of the pre-made audience of the Survival Horror game: Rabies Outbreak which explains the space of possibilities related to those who will use the game.
4. General specifications  
Contains an explanation of the general specifications or system requirements in making the Survival Horror game: Rabies Outbreak, which will also discuss the size, design basis, and targets that players want to achieve.

### B. Design

In developing a game, Unified Modeling Language (UML) is needed to know the flow or path of the game to be created. Unified Modeling Language starts from the game application being opened until the game ends. There are 4 diagrams used in the system, namely Flowchart, Activity Diagram, Primary Use Case, and Sequence Diagram.

#### 1. Use Case Diagram

From Figure 2, Primary use case contains settings used to set the background sound on or off and set the full screen display of the game (Fauzan et al. 2019; Arifin & Siahaan 2020). Help display information on instructions and controls in the game. About displays information about the game developer. While exit functions to exit the game. Start is used to play the game. The story scene displays information about rabies, the storyline, and the gameplay. Level 1 is the first level where there are six missions that must be completed with a normal level of difficulty (Mule, Waykar & Mahavidyalaya 2015; Aleryani

2016; Fauzan et al. 2021). Furthermore, level 2 is the second level which has two missions that must be completed and fights a big enemy that is difficult to defeat. The final scene of the story displays the characteristics of rabies and animals that cause rabies and displays fictional news information about the source of the rabies outbreak as the closing of the story.

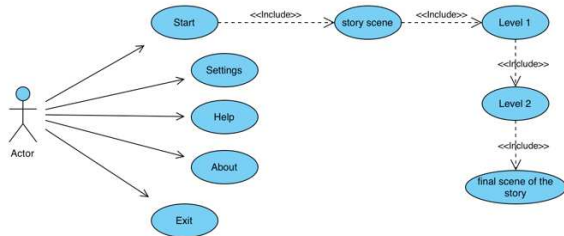

Figure. 2. Primary Use case

2. Flowchart

Based on figure 3, from the main menu the player presses the start game button to enter the storyline, if the player presses No they will return to the main menu while pressing Yes continues to play level 1, then at level 1 does the player complete the mission?, if No (failed) returns to the storyline Scene while if Yes (successful) continues to play level 2, then at level 2 does the player complete the mission?, if No (failed) returns to the storyline Scene while if Yes (successful) continues to enter the final story Scene(Nassi & Shneiderman 1973; Charntaweekhun & Wangsiripitak 2006; Ensmenger 2016; Chaudhuri 2020).

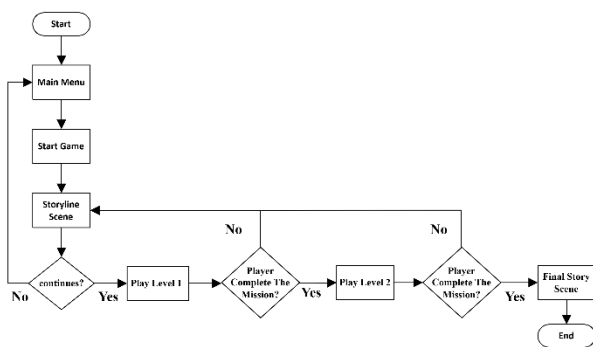

Figure. 3. Flowchart Start Game

3. Activity Diagram

In the Survival Horror game: Rabies Outbreak there is an activity diagram, namely the activity diagram in starting the game can be described as Figure 4.

- a) The player or user opens the Survival Horror game: Rabies Outbreak.
- b) On the main menu, the player selects start the game to open the story scene.
- c) On the story scene, the player selects the continue menu to change the story display panel.
- d) From the story panel, run the scene to start playing the game at level one.

- e) At level one, if the player fails to complete the mission, go to the story scene on the rabies transmission panel, if the player successfully completes the mission, continue playing at level two.
- f) At level two, if the player fails to complete the mission, go to the story scene on the rabies transmission panel, the player successfully completes the mission, go to the end of the story scene(Dumas & Ter Hofstede 2001; Bastos & Ruiz 2002; Eshuis 2006; Touseef et al. 2015; Al-Fedaghi 2021).

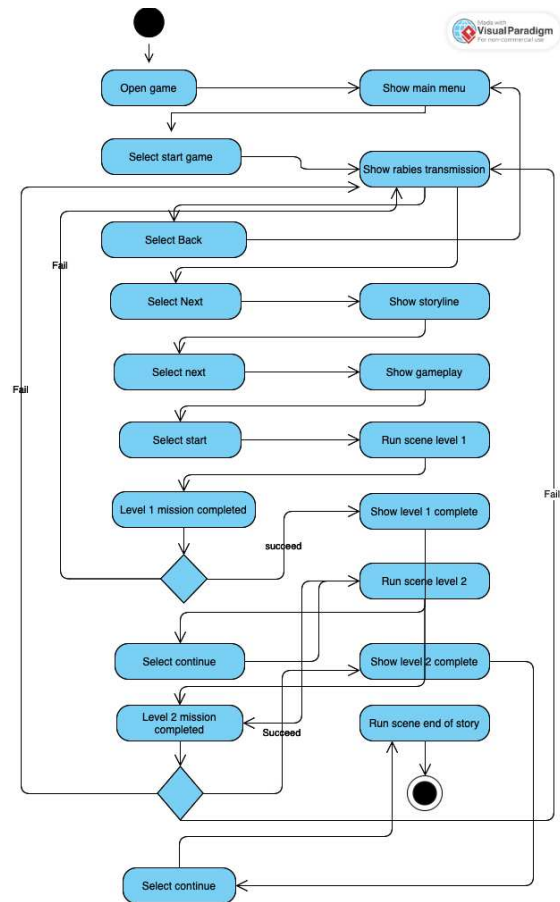

Figure. 4. Activity Diagram

C. Data collection

Data collection is the third stage, namely the stage of collecting material used to support the creation of the Survival Horror game: Rabies Outbreak, starting from images, videos, audio, and 3D model objects which function as asset objects for forming the game world, background music, storyline media, and button music.

D. Assembly

At the assembly stage, all objects and multimedia materials begin to be produced. The production refers to the design and collection of materials or models that have been done previously. The assembly stage of the Survival Horror game: Rabies Outbreak was created using the Unity Engine.



Figure 5. main menu page

The main menu is the main display of the game when the new game enters the application. In Figure 5 the main menu contains the title of the game, namely "Survival Horror: Rabies Outbreak" and each main menu button has its own function. When the player clicks the start button, it will go to the story scene, when the player clicks the settings button, it will display the game settings menu, if the player clicks the help button, it will display the help menu, if the player clicks the about button, it will display the about menu, if the player clicks the exit button, the player will exit the game.

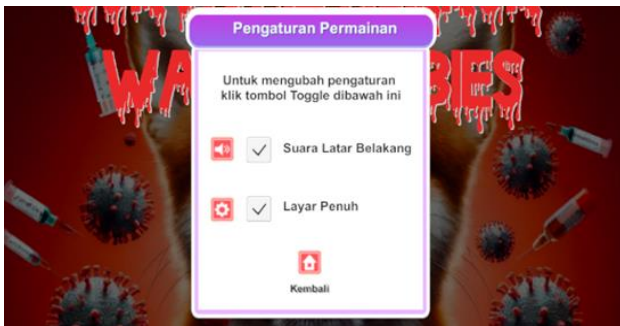

Figure 6. Settings menu view

Figure 6 shows the settings menu. This menu is created so that users can set the background sound settings or full screen display in the game by clicking the checkbox. The back button is used to go to the main menu.

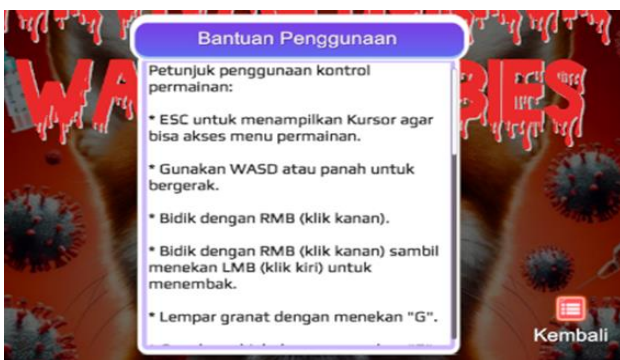

Figure 7. Help menu display

In figure 7 is a help menu that provides instructions and hints on how to use game features such as mouse control and keyboard usage, and in it there is a back button to go to the main menu.

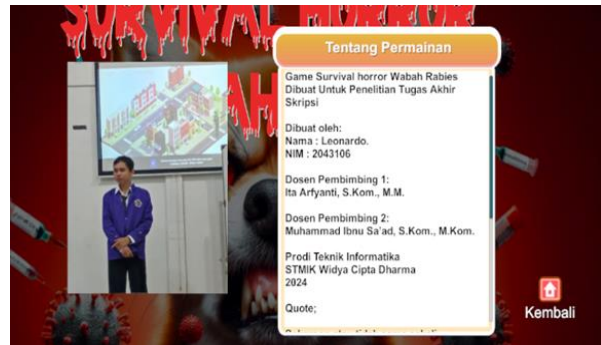

Figure 8. About menu view

In Figure 8, there is a menu to provide information about the game developer, details of the game name, profile picture, supervisor, and there is a back button to go to the main menu.



Figure 9. Rabies Video Panel View

Figure 9 is a video panel used to convey information about what rabies is, how it spreads, symptoms to watch out for, and the importance of prevention. This helps raise awareness of the dangers of rabies and how to prevent it, in the panel there is a checkbox to turn on and off the background sound and a skip video button to go to the storyline panel.



Figure 10. Storyline Panel View

In figure 10 is the story panel is a sequence of events that form a narrative in the story, starting from a police officer who is assigned to deliver vaccines to the homes of residents infected with rabies, anti-rabies rifles to fight infected animals, and missions that must be carried out. There is a next button to go to the game flow panel.



Figure. 11. HUD Level 2 View

Figure 11 is the HUD Level 2 View. Level 1 and level 2 players are introduced to the game environment, such as a mini map, graphic display, enemies, main characters, missions to be achieved, HUD user interface, and visual elements that players will encounter in the next level. Level one gives the impression of a dark night world with minimal lighting sources and human NPCs function as townspeople, dogs and cats as pets, and wolves as enemies. For level two Skybox, the sunset cube map sky background used in level two gives the impression of a sunset and there are two wolf mutations as major enemies.



Figure. 12. Failed and defeated view

Figure 12 is a losing display that will appear when the player loses or fails to complete the ongoing mission. There is a repeat button to repeat the game from the beginning.



Figure. 13. Winning view

Figure 13 is a winning display. This display will appear when the player wins and completes the mission in the game. There is a continuation button to continue the game.

#### E. White Box Testing

White Box testing will test several program modules in the game "Survival Horror: Rabies Outbreak", testing includes the type of testing, type of program or control program, expected results and test results. The modules tested are as follows:

#### Pathfinding Algorithm Program Code

```
public class Pathfinding : MonoBehaviour {
    public Grid grid;
    public List<Node> FindPath(Vector3 startPos, Vector3 targetPos)
    {
        Node startNode = grid.NodeFromWorldPoint(startPos);
        Node targetNode = grid.NodeFromWorldPoint(targetPos);
        List<Node> openSet = new List<Node>();
        HashSet<Node> closedSet = new HashSet<Node>();
        openSet.Add(startNode);
        while (openSet.Count > 0) {
            Node currentNode = openSet[0];
            for (int i = 1; i < openSet.Count; i++) {
                if (openSet[i].fCost < currentNode.fCost || openSet[i].fCost ==
currentNode.fCost && openSet[i].hCost < currentNode.hCost) {
                    currentNode = openSet[i];
                }
            }
            openSet.Remove(currentNode);
            closedSet.Add(currentNode);
            foreach (Node neighbour in grid.GetNeighbours(currentNode)) {
                if (!neighbour.walkable || closedSet.Contains(neighbour)) {
                    continue;
                }
            }
        }
    }
}
```

```

        int newMovementCostToNeighbour = currentNode.gCost + GetDistance(currentNode,
neighbour);
        if (newMovementCostToNeighbour < neighbour.gCost ||
!openSet.Contains(neighbour)) {
            neighbour.gCost = newMovementCostToNeighbour;
            neighbour.hCost = GetDistance(neighbour, targetNode);
            neighbour.parent = currentNode;
            openSet.Add(neighbour);
        }
    }
    (Node startNode, Node endNode) {
        rentNode = endNode;
        currentNode = currentNode.parent;
    }
    path.Reverse();
    grid.path = path;
    return path;
}

int GetDistance(Node nodeA, Node nodeB) {
    int dstX = nodeA.gridX - nodeB.gridX;
    int dstY = nodeA.gridY - nodeB.gridY;
    int distance = Mathf.RoundToInt(Mathf.Sqrt(dstX * dstX + dstY * dstY));
}

```

#### a. Flow Graph Pathfinding Algorithm

To simplify the program code, it is converted into a flow graph, as can be seen in Figure 14.

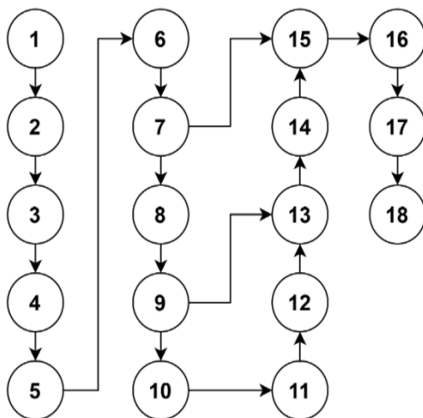

Figure 14. Flow Graph Pathfinding Algorithm

#### 1. Cyclomatic Complexity

Based on Figure 14, the cyclomatic complexity can be calculated as follows:

$$\begin{aligned}
 V(G) &= E - N + 2 \\
 V(G) &= 19 - 18 + 2 \\
 V(G) &= 1 + 2 \\
 V(G) &= 3
 \end{aligned} \tag{1}$$

#### 2. Independent Path

Path 1: 1,2,3,4,5,6,7,15,16,17,18  
 Path 2: 1,2,3,4,5,6,7,8,9,13,14,15,16,17,18  
 Path 3: 1,2,3,4,5,6,7,8,9,10,11,12,13,14,15,16,17,18

Based on the test results, the same Cyclomatic Complexity value is produced, namely 3, so it can be concluded that the search process with the Pathfinding algorithm runs well, because each test produces the same value.

#### Pathfinding Algorithm Program Code

```

public class Pathfinding : MonoBehaviour {
    public Grid grid;
    public List<Node> FindPath(Vector3 startPos, Vector3 targetPos) {
        Node startNode = grid.NodeFromWorldPoint(startPos);
        Node targetNode = grid.NodeFromWorldPoint(targetPos);
        List<Node> openSet = new List<Node>();
        HashSet<Node> closedSet = new HashSet<Node>();
        openSet.Add(startNode);
        while (openSet.Count > 0) {
            Node currentNode = openSet[0];
            for (int i = 1; i < openSet.Count; i++) {
                if (openSet[i].fCost < currentNode.fCost || openSet[i].fCost ==
currentNode.fCost && openSet[i].hCost < currentNode.hCost) {
                    currentNode = openSet[i]; }
            openSet.Remove(currentNode);
            closedSet.Add(currentNode);
            foreach (Node neighbour in grid.GetNeighbours(currentNode)) {
                if (!neighbour.walkable || closedSet.Contains(neighbour)) {
                    continue;
                }
            }
        }
    }
}

```

```

    int newMovementCostToNeighbour = currentNode.gCost + GetDistance(currentNode,
neighbour);
    if (newMovementCostToNeighbour < neighbour.gCost ||
!openSet.Contains(neighbour)) {
        neighbour.gCost = newMovementCostToNeighbour;
        neighbour.hCost = GetDistance(neighbour, targetNode);
        neighbour.parent = currentNode;
        openSet.Add(neighbour);
    } }
(Node startNode, Node endNode) {
    rentNode = endNode;
    currentNode = currentNode.parent; }
path.Reverse();
grid.path = path;
return path; }
int GetDistance(Node nodeA, Node nodeB) {
    int dstX = nodeA.gridX - nodeB.gridX;
    int dstY = nodeA.gridY - nodeB.gridY;
    int distance = Mathf.RoundToInt(Mathf.Sqrt(dstX * dstX + dstY * dstY));}

```

#### b. Flow Graph Algorithm A Star

To simplify the program code, it is converted into a flow graph, as can be seen in Figure 15.

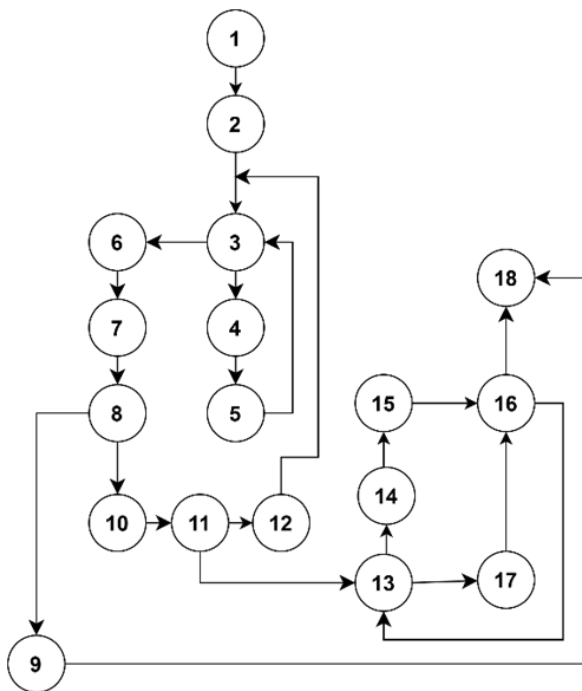

Figure. 15. Flow Graph Pathfinding Algorithm

#### 1. Cyclomatic Complexity

Based on Figure 23, the cyclomatic complexity can be calculated as follows:

$$V(G) = E - N + 2 \quad (1)$$

$$V(G) = 22 - 18 + 2$$

$$V(G) = 4 + 2$$

$$V(G) = 6$$

#### 2. Independent Path

Path 1: 1,2,3,6,7,8,9,18

Path 2: 1,2,3,4,5,6,3,7,8,9,18

Path 3: 1,2,3,4,5,6,3,7,8,10,11,13,17,16,18

Path 4: 1,2,3,4,5,6,3,7,8,10,11,13,14,15,16,18

Path 5: 1,2,3,4,5,6,3,7,8,10,11,12,3,6,7,8,9,18

Path 6: 1,2,3,4,5,6,3,7,8,10,11,12,3,6,7,8,10,11,13,17,16,18

Based on the test results, the same Cyclomatic Complexity value is produced, namely 6, so it can be concluded that the search process with the A\* (A star) algorithm runs well, because each test produces the same value.

#### F. Beta Testing

Beta testing is a test that is carried out objectively which is tested directly by the questionnaire fillers filled out by 10 respondents. Based on the questionnaire data, the percentage of each answer can be found using formula (2), result of Beta Testing in table 1:

Table 1. Beta testing table

No	Question	Evaluation				Total
		VG	G	P	VP	
1	How does the game's main menu design look like?	2	8	0	0	10
2	How would you rate the character's health, ammunition, and resource information being displayed clearly in the Heads-Up Display (HUD)?	4	6	0	0	10
3	How are HUD elements such as the mini-map, mission indicators, and character status placed?	3	7	0	0	10
4	Does the gameplay in this game make you more aware of the dangers of rabies?	2	6	0	2	10
5	Do you feel that this game provides a balance between rabies education and entertainment?	4	4	1	1	10
6	How about the storyline in this game? Do you think the story conveys information about rabies in an easy-to-understand way?	4	5	1	0	10
7	Do you think the difficulty level of level 1 and level 2 in the game is appropriate?	3	7	0	0	10
8	What do you think about the way this game depicts the transmission of rabies?	3	7	0	0	10
9	How do all the features in the game work according to their function?	3	7	0	0	10
10	How effective do you think education to raise awareness about rabies is in implementing the game?	6	3	1	0	10
Total		34	60	3	3	100

From the percentage above, it can be concluded that 6 out of 10 respondents or 60% stated it very good. 3 out of 10 respondents or 30% stated good. Table 1 shows 1 out of 10 respondents or 10% stated less, and 0 out of 10 respondents or 0% stated very less.

From all the answers of 10 respondents to 10 questions, 100 total choices have been collected and from the 100 choices there are:

Very Good	: $34/100 * 100\% = 34\%$
Good	: $60/100 * 100\% = 60\%$
Poor	: $3/100 * 100\% = 3\%$
Very Poor	: $3/100 * 100\% = 3\%$

From the percentage results above, it can be concluded that on average, respondents answered very good 34%, good 60%, poor 3% and 3% very poor.

#### G. Distribution

At this stage, the creation of the Survival Horror Game: Rabies Outbreak is packaged into an application that can be played on the Windows 10 platform and above. Distribution of the application using social media Instagram posts there is a Google Drive barcode link where the game folder is packaged into one 400MB ZIP file to make it easier to download. The final product of this application is distributed to the Department of Livestock and Animal Health of East Kalimantan Province.

#### IV. CONCLUSION

This study successfully developed and implemented Survival Horror: Rabies Outbreak, an educational game integrating the A\* (A Star) Pathfinding Algorithm to enhance enemy AI behavior while promoting rabies awareness. By combining 3D isometric projection,

interactive storytelling, and AI-driven enemy pursuit, the game delivers an engaging and immersive experience that balances education and entertainment.

The implementation of the A\* algorithm significantly improved the realism of enemy movements, providing a dynamic and challenging gameplay experience. Beta testing results indicate that 60% of respondents rated the game positively, validating its effectiveness as an educational tool while maintaining a compelling survival horror atmosphere.

Beyond its entertainment value, the game serves as an innovative approach to public health education, reinforcing critical knowledge on rabies transmission, prevention, and first aid measures. The findings suggest that gamification, when combined with AI-driven mechanics, can effectively enhance learning retention and engagement.

Future research could explore adaptive AI mechanisms, multi-player functionalities, and VR/AR integration to further optimize engagement and effectiveness. Additionally, broader user testing with diverse demographics would provide deeper insights into the game's long-term educational impact.

Through the fusion of serious gaming and AI-driven mechanics, this study highlights the potential of game-based learning in tackling real-world health challenges, setting a foundation for future advancements in digital education and public health initiatives.

#### REFERENCES

- Aleryani, A.Y., 2016, 'Comparative study between data flow diagram and use case diagram', *International Journal of Scientific and Research Publications*, 6(3), 124–126.

- Arifin, M.N. & Siahaan, D., 2020, 'Structural and semantic similarity measurement of UML use case diagram', *Lontar Komputer: Jurnal Ilmiah Teknologi Informasi*, 11(2), 88.
- Charntaweekhun, K. & Wangsiripitak, S., 2006, *Visual programming using flowchart*, 2006 *International Symposium on Communications and Information Technologies*, 1062–1065, IEEE.
- Chaudhuri, A.B., 2020, *Flowchart and algorithm basics: The art of programming*, Mercury Learning and Information.
- Crowcroft, N.S. & Thampi, N., 2015, 'The prevention and management of rabies', *Bmj*, 350.
- Ensmenger, N., 2016, 'The multiple meanings of a flowchart', *Information & Culture*, 321–351.
- Fauzan, R., Siahaan, D., Rochimah, S. & Triandini, E., 2019, *Use case diagram similarity measurement: A new approach*, 2019 *12th International Conference on Information & Communication Technology and System (ICTS)*, 3–7, IEEE.
- Fauzan, R., Siahaan, D., Rochimah, S. & Triandini, E., 2021, 'A different approach on automated use case diagram semantic assessment', *International Journal of Intelligent Engineering and Systems*, 14(1), 496–505.
- Fine, M.R., 2002, *Beta testing for better software*, John Wiley & Sons.
- Hai-Jew, S. & Hai-Jew, S., 2019, 'Alpha testing, beta testing, and customized testing', *Designing instruction for open sharing*, 381–428.
- Hill, R.K., 2016, 'What an algorithm is', *Philosophy & Technology*, 29, 35–59.
- Hocking, J., 2022, *Unity in Action: Multiplatform game development in C*, Simon and Schuster.
- Ju, C., Luo, Q. & Yan, X., 2020, *Path planning using an improved a-star algorithm*, 2020 *11th international conference on prognostics and system health management (PHM-2020 Jinan)*, 23–26, IEEE.
- Kessels, J., Tarantola, A., Salahuddin, N., Blumberg, L. & Knopf, L., 2019, 'Rabies post-exposure prophylaxis: A systematic review on abridged vaccination schedules and the effect of changing administration routes during a single course', *Vaccine*, 37, A107–A117.
- Lambora, A., Gupta, K. & Chopra, K., 2019, *Genetic algorithm-A literature review*, 2019 *international conference on machine learning, big data, cloud and parallel computing (COMITCon)*, 380–384, IEEE.
- Mule, S.S., Waykar, Y. & Mahavidyalaya, S.V., 2015, 'Role of USE CASE diagram in s/w development', *International Journal of Management and Economics*.
- Nadeem, M. & Panda, P.K., 2020, 'Survival in human rabies but left against medical advice and death followed—Community education is the need of the hour', *Journal of family medicine and primary care*, 9(3), 1736–1740.
- Nassi, I. & Shneiderman, B., 1973, 'Flowchart techniques for structured programming', *ACM Sigplan Notices*, 8(8), 12–26.
- Pardede, S.L., Athallah, F.R., Huda, Y.N. & Zain, F.D., 2022, 'A review of pathfinding in game development', *CEPAT] Journal of Computer Engineering: Progress, Application and Technology*, 1(01), 47.
- Permana, S.H., Bintoro, K.Y., Arifitama, B. & Syahputra, A., 2018, 'Comparative analysis of pathfinding algorithms a\*, dijkstra, and bfs on maze runner game', *IJISTECH (International J. Inf. Syst. Technol.*, 1(2), 1.
- Preiss, S., Chanthavanich, P., Chen, L.H., Marano, C., Buchy, P., Hoorn, R. van, Vonk Noordegraaf, M. & Mukherjee, P., 2018, 'Post-exposure prophylaxis (PEP) for rabies with purified chick embryo cell vaccine: a systematic literature review and meta-analysis', *Expert review of vaccines*, 17(6), 525–545.
- Russell, S.J. & Norvig, P., 2016, *Artificial intelligence: a modern approach*, Pearson.
- Shaykhian, C.A., 2007, *Software Testing: White Box and Black Box*.
- Suyanto, S.T. & Sc, M., 2007, 'Artificial Intelligence: Searching, Reasoning, Planning and Learning', *PenerbitInformatika, Bandung, Indonesia*.
- Tarantola, A., Tejiokem, M.C. & Briggs, D.J., 2019, 'Evaluating new rabies post-exposure prophylaxis (PEP) regimens or vaccines', *Vaccine*, 37, A88–A93.