

Machine Learning-based Indoor Positioning Systems Using Multi-Channel Information

Shu-Hung Lee ¹, Chia-Hsin Cheng ², Tzu-Huan Huang ² & Yung-Fa Huang ^{3,*}

¹School of Intelligent Manufacturing and Automotive Engineering, Guangdong Business and Technology University, Qixingyan Scenic Area, Zhaoqing, Guangdong, 526020 China

²Department of Electrical Engineering, National Formosa University, Wenhua Rd, Huwei, Yunlin, 632301 Taiwan

³Department of Information and Communication Engineering, Chaoyang University of Technology, Jifeng E. Rd., Wufeng District, Taichung, 413310 Taiwan

Corresponding author: yfahuang@cyut.edu.tw

Abstract

The received signal strength indicator (RSSI) is a metric of the power measured by a sensor in a receiver. Many indoor positioning technologies use RSSI to locate objects in indoor environments. Their positioning accuracy is significantly affected by reflection and absorption from walls, and by non-stationary objects such as doors and people. Therefore, it is necessary to increase transceivers in the environment to reduce positioning errors. This paper proposes an indoor positioning technology that uses the machine learning algorithm of channel state information (CSI) combined with fingerprinting. The experimental results showed that the proposed method outperformed traditional RSSI-based localization systems in terms of average positioning accuracy up to 6.13% and 54.79% for random forest (RF) and back propagation neural networks (BPNN), respectively.

Keywords: *channel state information; indoor positioning; machine learning; RSSI; random forest; times.*

Introduction

Nowadays, when people try to find an address, get lost, or are unsure of their current location, most of them will use the positioning service provided by the Google Maps App to locate and track the target points. The earliest positioning service technology can be traced back to the global positioning system (GPS) developed in the nineteenth century. The target in this technology uses received satellite signals to perform positioning algorithms to obtain 3D position information [1-4]. The positioning error decreases with an increase in the number of satellites that signals can be received. This method can accurately locate and track outdoor places but in complex environments, such as indoor places and deep mountain environments, the target cannot maintain the line of sight (LOS) with satellites, which makes the positioning accuracy not good enough [5-7].

In recent years, 5G mmWave technology has also been in use for localization in addition to GPS. Reference [8] proposed low-complexity channel estimation approaches in mmWave multiple-input single-output systems for accurate indoor positioning. Reference [9] provides a brief overview of the use of massive MIMO arrays for indoor localization in 5G, while a novel method for single-snapshot localization and mapping of the radio environment using a single-antenna receiver in 5G mmWave systems was proposed in Reference [10].

Indoor positioning topology is carried out according to a positioning algorithm, and the metrics measured between the transmitting and receiving devices are taken as an index of positioning judgment. The metrics include time of arrival (TOA), time difference of arrival (TDOA), angle of arrival (AOA), received signal strength indicator (RSSI), etc. TOA and TDOA require a high synchronization property for hardware devices [11-14], AOA requires a directional antenna [15-18], RSSI judges the signal strength between transceivers and the distance is measured by the logarithmic path loss method. Among them, the RSSI calculation is the most convenient. It does not require additional hardware equipment for measurement, so that related studies have been developed successively, such as enhancing the reliability of environmental changes to reduce data collection [19-22], data

filtering [23-26], and the comparison of indoor positioning with different communication technologies [27-30]. However, the accuracy of positioning using RSSI is susceptible to reflection and absorption from walls and non-stationary objects such as doors and people. Thus, it is necessary to increase transceivers in the environment to reduce positioning errors.

To reduce positioning errors, it is necessary to increase the number of transceivers in the environment. However, some research has proposed advanced methods for direct position estimation in dynamic multipath environments that do not require an extensive deployment of transceivers. For example, [31] presents an algorithm that estimates positions of multi-antenna receivers in dynamic multipath environments using narrowband broadcast radio signals. Reference [32] proposes exploiting sparse spatiotemporal features of the received waveforms to achieve localization in multipath environments using a tensor-based algorithmic framework. Moreover, a novel approach that combines angle and velocity information for direct position estimation in multipath environments where standard AOA-based techniques fail is presented in [33].

In addition, there are many types of machine learning (ML) algorithms and models that can be used for different purposes, for instance, neural networks (NN) [34,35] and deep learning [36]. This paper proposes an indoor positioning technology that adopts the machine learning (ML) algorithms of random forest (RF) and back propagation neural networks (BPNN) using channel state information (CSI) combined with finger-printing to improve the problem that the accuracy of RSSI positioning is easily affected by various indoor environmental factors.

The rest of this paper is organized as follows. Related technologies are reviewed in Section 2. The experimental environments and research methods are described in Section 3. The experimental results are discussed in Section 4, and brief conclusions are given in Section 5.

Background

Channel State Information

CSI refers to known channel properties of a communication link. This information describes how a signal propagates from the transmitter to the receiver and represents the combined effect of, for example, scattering, fading, and power decay with distance. The CSI makes it possible to adapt transmissions to current channel conditions, which is crucial for achieving reliable communication with high data rates in multi-antenna systems. Therefore, multi-input multi-output-orthogonal frequency division multiplexing (MIMO-OFDM) precoding is used to reduce environmental noise interference and receive multi-channel data [30].

When an OFDM system uses a channel frequency response (CFR) of statistical CSI to perform CSI data operations, the frequency responses of different frequencies in a frequency band are slightly different due to frequency selective fading in the frequency domain. Assume that its CFR is as shown in Eq. (1) in the case of infinite bandwidth.

$$H_k = |H(k)|e^{\angle H(k)} \quad (1)$$

where $|H(k)|$ is the k -th subcarrier amplitude, and $\angle H(k)$ is the phase of the k -th subcarrier. The CSI data collected each time will be assembled into a set of matrices, as shown in Eq. (2).

$$H = [H_1, H_2, H_3, \dots, H_i] \quad (2)$$

where H_i is the i -th data of the receiving antenna. The CSI data, a complex number, can be expressed by Eq. (3):

$$H_i = I_i + jQ_i \quad (3)$$

where I_i and Q_i are the real part and imaginary part of the i -th CSI data respectively.

Fingerprinting

Fingerprinting uses two phases to predict the location of the target, namely the offline phase and the online phase. In the offline phase, the environment is divided into several areas and randomly arranges reference points (RP) in these areas, and multiple transmitters are set up in the environment. Then environment exploration is conducted to collect the data of metrics of the detected radio signals from the transmitters at many RPs of known locations to build an offline fingerprint database. Hence, each RP can be identified by its fingerprint. In the online phase, the target measures metrics of the detected radio signals from the transmitters at its position and uses the machine learning algorithm to predict the target's position in the environment. The machine learning model is trained by the fingerprint database built in offline mode.

Random Forest

Random Forest (RF) uses bagging to generate multiple sample sets and then generates multiple decision trees (DT) through node segmentation and aggregates them into a forest, and finally makes predictions [37-39]. Bagging is an ensemble learning method. It uses bootstrapping to randomly extract a fixed number of sample sets from the original database. After that the analyzed sample set data is put back into the original database. It is then repeatedly extracted and recursed to form a variety of different sample sets.

For classification problems, the majority voting method is used to determine the output result. If it is a regression problem, the output is the average prediction of the individual trees. The node segmentation of DT first uses Classification and Regression Tree (CART) for node classification, and then performs node segmentation through the Gini algorithm. The formula can be expressed as follows:

$$I_H = -\sum_{j=1}^c p_j \log_2(p_j) \quad (4)$$

where c is the number of child nodes after the parent node is divided, and p_j is the probability of this child node in the class. Information gain (IG) is used to measure the quality of node classification, taking node A as an example, as shown in Eq. (5):

$$IG(D_p, A) = I_H(D_p) - \sum_{j=1}^m \frac{N_j}{N} I_H(D_j) \quad (5)$$

where $I_H(D_p)$ is the entropy of the parent node, $I_H(D_j)$ is the entropy of each split child node, N is the sample number of parent node, and N_j is the sample number of each child node.

In the procedure of RF algorithm, first, the original database uses the bagging method to randomly select data features and generate an input sample set. Secondly, it uses the Gini algorithm to split the nodes to form multiple sets of DTs. Then it determines whether the number of sample sets needs to be increased. If the specified number of samples is not reached, the input sample set will be returned to the original database recursively until the set number of samples is reached. Finally, the majority voting method is used for the classification problem. The average method is used to judge the results of the regression problem.

Back Propagation Neural Network

The BPNN architecture is mainly divided into an input layer, a hidden layer and an output layer, and the predicted value of the output is calculated through forward propagation, after which the weights are updated by back propagation. In this way, the model converges through repeated operations [40,41]. Figure 1 shows the procedure of the BPNN algorithm. First, each input data is calculated linearly with the weight and is then summed up at the next neuron. Finally, the activation function converts the linear equation into a nonlinear equation to output the predicted value. Then it is checked whether the pre-set number of iterations is reached. If not, then the weight of each neuron is updated through backpropagation. Otherwise, the predicted result will be the output.

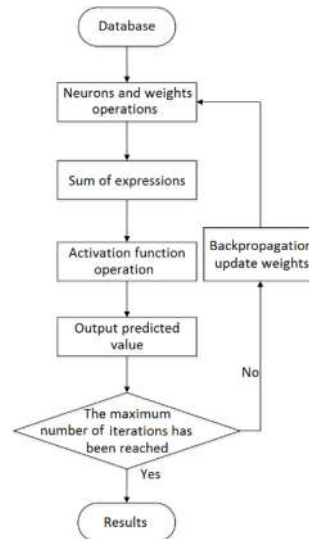

Figure 1 The procedure of the BPNN algorithm.

Experimental Environment and Research Methods

The experimental environment along with the hardware equipment used in this paper will be described in this section. Moreover, the detailed research methods contain RF and BPNN combined with fingerprinting, which is also depicted here.

Experimental Environment

The specifications of the experimental equipment used in this study are described as follows. The transmitting device was an AP with two antennas, using a laptop as the receiving device. An IWL5300 network card with three receiving antennas was installed in the laptop, which received the CSI data through three antennas. We used Linux 802.11n CSI Tool's commands to collect the CSI data and adjust the hardware parameters. The experimental environment was located behind the communication classroom on the fifth floor of the Department of Electrical Engineering, National Formosa University. The total area behind the communication classroom was 9.9 meters by 5 meters, and the transmitter AP was placed in the classroom behind the middle aisle. A schematic diagram is shown in Figure 2.

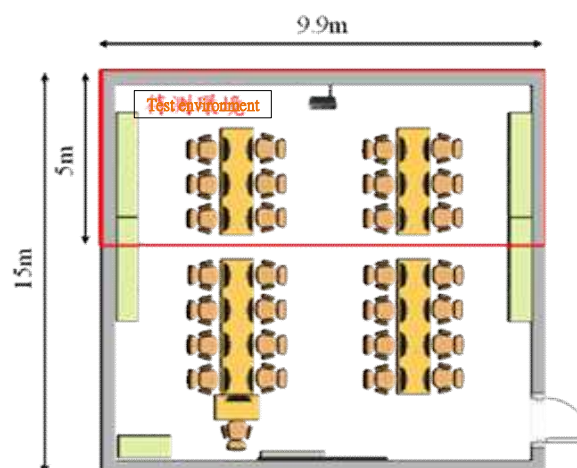

Figure 2 Schematic diagram of the experimental environment.

The receiver could receive data from up to three antennas due to the effect of MIMO-OFDM. Each antenna collected 30 sub-carriers. Thus, the three antennas could receive a total of 90 sub-carriers. The antennas were arranged in descending order according to the received signal strength and were named antenna A, Antenna B, and Antenna C. The strength curve of the three antenna shows in Figure 3.

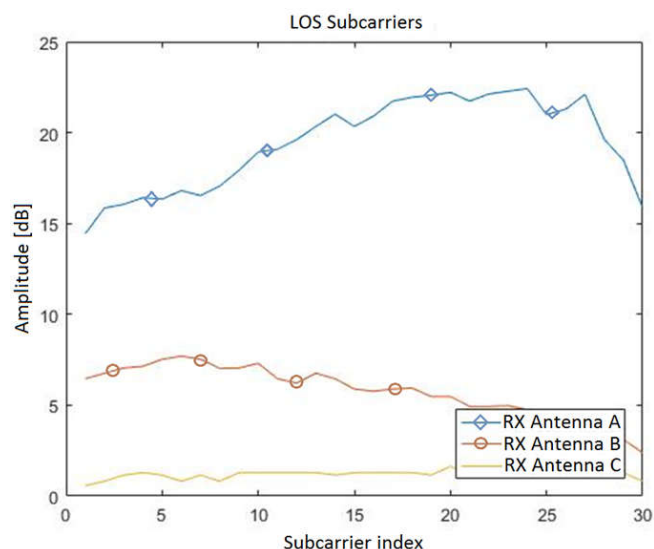

Figure 3 The strength curves of the three antennas.

Research Methods

Figure 4 shows the target positioning procedure of the RF algorithm combined with the fingerprinting method. First, the RP's topology was performed in the testing environment, the AP transmission rate was changed, and then the fingerprinting method was used to collect the data from each RP to build a database. We selected Antenna A of the strongest signal for amplitude filtering and then judged the area positioning through the RF algorithm. The filtered offline database was randomly selected by bagging to generate a sample set, and the DT was generated by the Gini algorithm. Then it was checked if the number of sample sets had to be increased according to the number of decision trees, n . Assuming that the maximum number of decision trees n was 2,000, if n did not reach 2,000, the data was put back into the offline database to generate multiple sets of DT results. Conversely, if n had reached 2,000, multiple sets of DT results were predicted. We used these for the classification task in which the output result was judged by the majority voting method. Finally, the fingerprint model of Antenna A was applied to Antenna B and Antenna C to compare the positioning accuracy of each received antenna.

The procedure of the target localization of the BPNN algorithm combined with the fingerprinting method is shown in Figure 5. First, the RP topology was performed in the environment to be tested, the AP transmission rate was adjusted and then the fingerprint method was used to detect the data from each RP and a database was built. The three antennas could receive 90 sub-carriers. We selected Antenna A with a strong signal for amplitude filtering and then judge the target positioning through the BPNN algorithm.

The input layer is the number of received sub-carriers and performs linear operation with the weight, which is added up at the next neuron, and finally the linear equation is converted into a nonlinear equation through the activation function ReLU and the predicted value is output. Then judge whether the set number of iterations ep is reached. Assuming that the maximum number of iterations ep is 1,000, if ep has not reached 1,000, the error is calculated with multi-classification loss function CE through backpropagation, and the weights between the neurons are updated through optimization function SGD. In contrast, when ep reaches 1,000, the output of the positioning accuracy of Antenna A is performed, and finally, the neural network model is applied to Antenna B and Antenna C to compare the positioning accuracy of each receiving antenna.

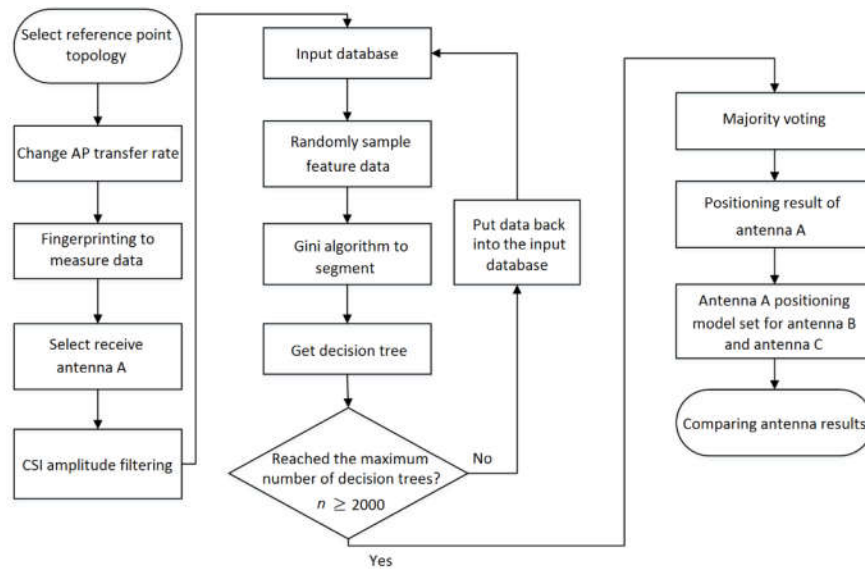

Figure 4 The procedure of RF combined with the fingerprinting method.

Experimental Results and Discussion

Zone I was located in the middle aisle in the environment where the signal was transmitted under the LOS situation, so the signal could not easily be disturbed in the area. Another zone was located in the left area and the right area, where the signal could easily be disturbed because the transmission path suffered from interference by obstacles, for example, tables, chairs, and screens. Zone II in the environment was divided into two levels of interference. The areas of different interference levels in the experimental environment are shown in Figure 6.

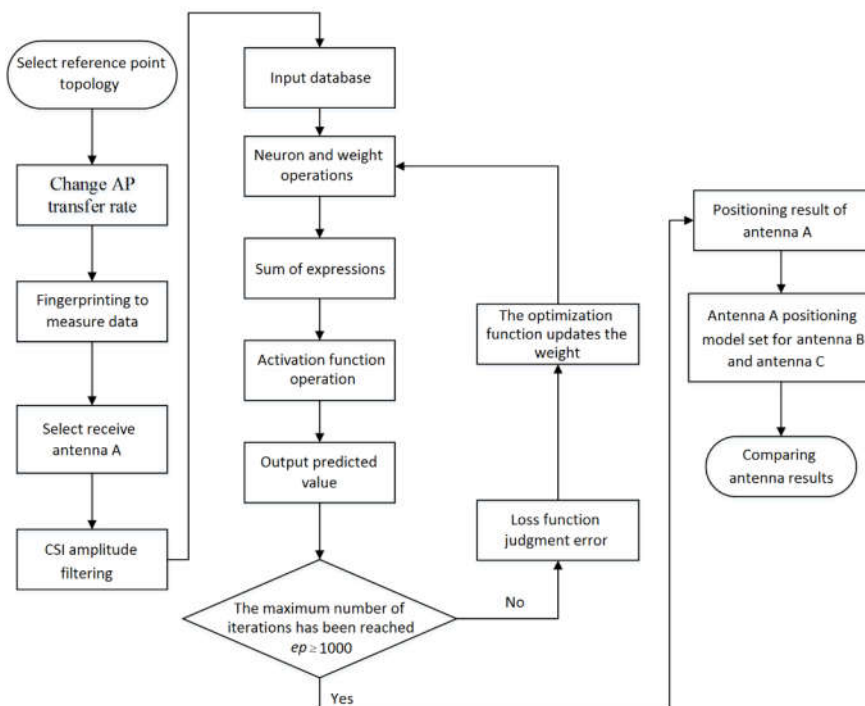

Figure 5 The procedure of BPNN combined with the fingerprinting method.

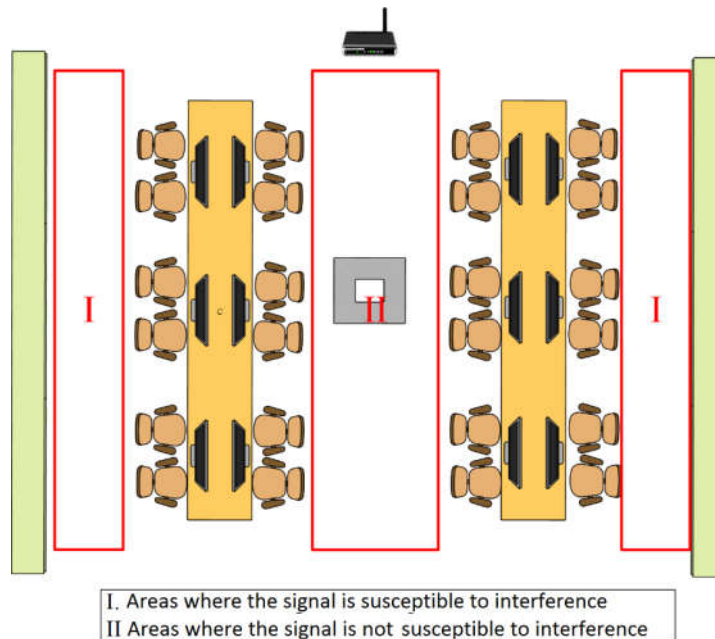

Figure 6 The areas of different interference levels in the experimental environment.

The amplitude response for the different subcarriers on antenna A was measured first to check the possible relationship between the positioning accuracy and the number of subcarriers. Figure 7(a) and (b) show the amplitude response for 5 and 30 subcarriers on Antenna A, respectively. From Figure 7, it is clear that the more subcarriers there are, the more CSI information there is.

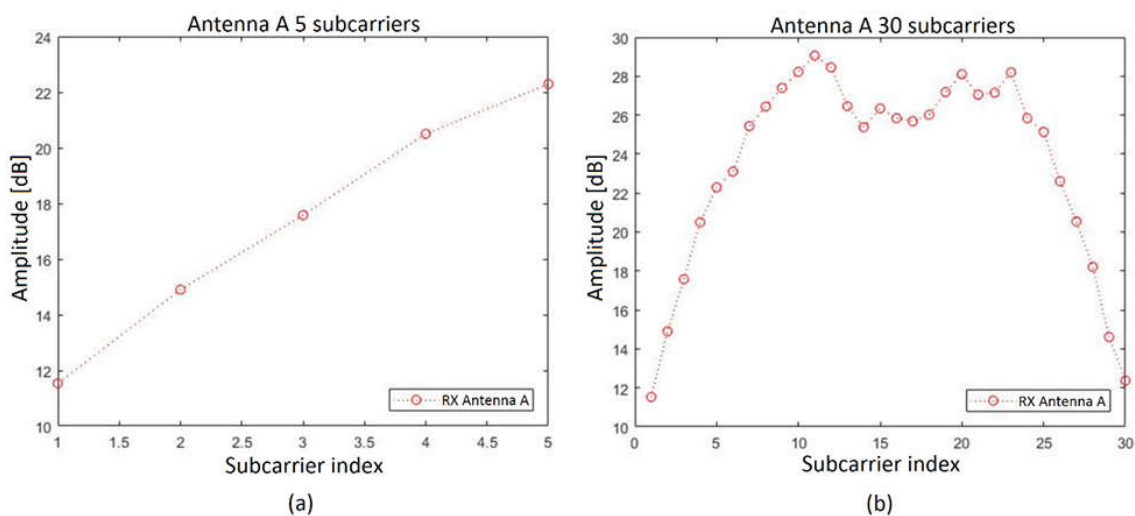

Figure 7 Schematic diagram of the experimental environment.

To investigate the performance of the proposed ML-based positioning method combined with fingerprinting using CSI information compared to RSSI information, three different experimental environments (A, B, and C) were set up to ensure the reliability of the experimental results. In Environment A, the AP transmission rate was 60 Mbps, and the experimental environment was divided into 12 areas. Each area was further separated into 4 RPs, so Environment A had 48 RPs in total. Every RP could receive 90 subcarrier signals. The layout plan of Environment A is shown in Figure 8.

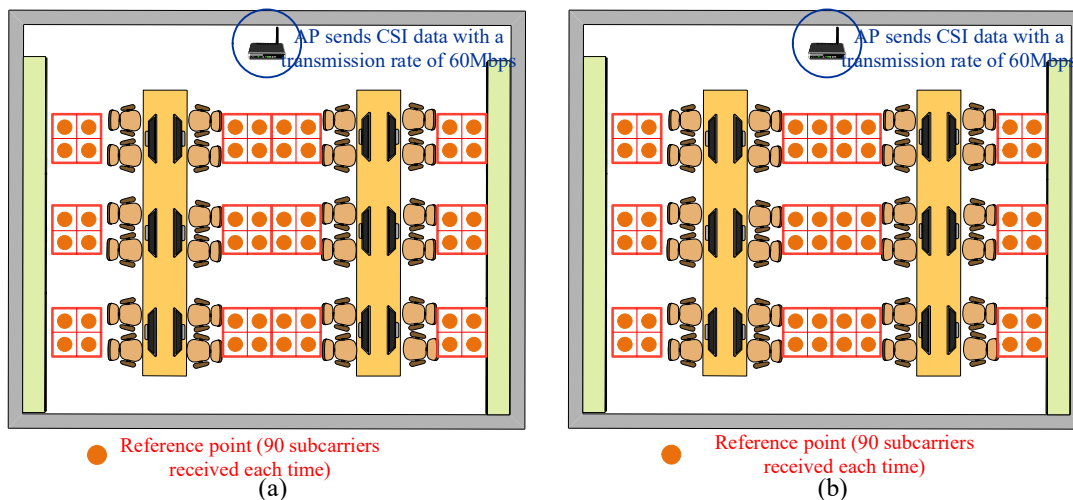

Figure 8 The layout plan of environment A: (a) training environment, (b) testing environment.

Environment B was an area (Zone II) where the signal was not easily interfered. The difference with Environment A is that only the middle aisle was used for target positioning. The AP transmission rate was 60 Mbps. The experimental environment to be tested was divided into six areas and separated each area into 4 RPs. There were 24 RPs in total in Environment B. Each RP could receive 90 subcarrier signals. The layout plan of Environment B is shown in Figure 9(a). Environment C was similar to Environment A. The only different parameter was the number of subcarriers used for transmission. The number of subcarriers was 15 for Environment C and 90 for Environment A. Environment C was used to investigate the impact of the difference in the number of input subcarriers. The layout plan of Environment C is shown in Figure 9(b).

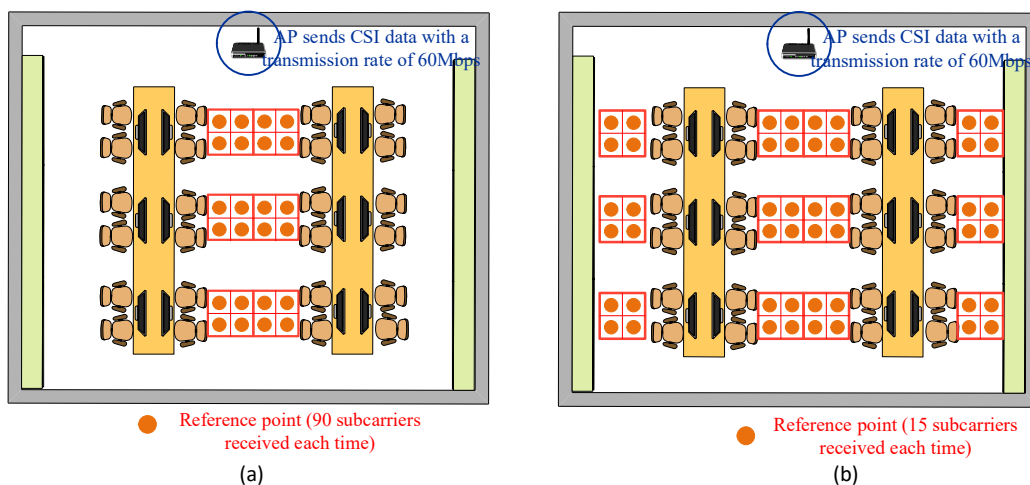

Figure 9 Schematic diagram for training and testing with (a) Environment B, (b) Environment C.

In this study, two machine learning models, RF and BPNN, were tested in three environments using the metrics of RSSI and CSI respectively to analyze and compare the accuracy of positioning and the impact factors. For the RSSI case, the experimental results are listed in Table 1. The positioning accuracies of RF in Environments A, B, and C were 85.22%, 94.72%, and 82.22% respectively, and the average value was 87.39%. Similarly, BPNN scored 20.41%, 43.88%, and 20.41% respectively, and the average was 28.23%.

The experimental results for the CSI case are shown in Table 2. The positioning accuracies for RF in Environments A, B, and C were 99.3%, 100%, and 81.25% respectively, and the average was 93.52%. Similarly, BPNN scored 100%, 100%, and 49.16% respectively, and the average was 83.05%.

Table 1 Experimental results of RSSI positioning accuracy in different environments.

M L Method	Environment			Average
	A	B	C	
RF (%)	85.22	94.72	82.22	87.39
BPNN (%)	20.41	43.88	20.41	28.23

Table 2 Experimental results of CSI positioning accuracy in different environments.

M L Method	Environment			Average
	A	B	C	
RF (%)	99.3	100	81.25	93.52
BPNN (%)	100	100	49.16	83.05

From Table 1, it can be seen that the positioning accuracy for RF in Environments A, B, and C was 64.81%, 50.84%, and 61.81% higher than that of BPNN respectively in the RSSI case. Thus, the RF model is more suitable for using RSSI as input data than BPNN. From Table 2, for the CSI case, the positioning accuracy of BPNN was better than RF in Environment A by 0.7%. Both BPNN and RF were 100% correct in Environment B, but BPNN was 32.09% lower than RF. Environment B was insusceptible to interference, so the positioning accuracy was higher than for the other environments. Environment C used 15 subcarriers for transmission, 83.3% less than A, which used 90 subcarriers. This means that the number of input data for the BPNN model in Environment C was smaller than in A, which is why the positioning accuracy of BPNN in Environment C was so much worse than in A.

The summary of the experimental results is as follows:

1. Regardless of RF or BPNN, positioning accuracy is affected by environmental noise.
2. For the RF model, either using the measured values of RSSI or those of CSI, the positioning accuracy had at least a good performance, i.e., at least 81.28%.
3. The positioning accuracy of the BPNN model is greatly affected by the number of subcarriers.
4. When using CSI as the input data for predicting the target position, the average positioning accuracy of RF or BPNN was better than that of using RSSI, which was increased by 6.13% and 54.79% respectively.

Conclusion

This paper proposed an ML model combined with fingerprinting for indoor localization using CSI information. Experiments were conducted on the positioning accuracy performance of RF and BPNN machine learning models using RSSI and CSI information, respectively, in three different environments. The experimental results showed that when RF and BPNN were used to determine the target position, the average positioning accuracy of using CSI information was increased by 6.13% and 54.79%, respectively, compared with RSSI information. Therefore, for the RF and BPNN machine learning algorithms, the use of CSI can effectively improve the positioning accuracy of the target. However, it was found from the experimental results that the number of subcarriers impacts the performance of the BPNN model. The relationship between the number of subcarriers and the positioning accuracy of BPNN is worthy of further research in the future. Whether the CSI information input can improve other ML models for indoor positioning is also worth considering.

The main objective of this paper was to show the effect and practical advantages of the proposed indoor positioning technology, which leverages channel state information (CSI) with a combination of fingerprinting and a machine learning algorithm. Even though this approach demands more computational resources compared to conventional techniques like RSS/TOA/AOA, the increased computational cost of the combined fingerprinting and machine learning algorithm of the CSI approach is justified by the superior accuracy it provides in indoor positioning when compared to traditional methods such as RSS/TOA/AOA.

Acknowledgements

This research was funded by National Science and Technology Council (NSTC), R.O.C. grant number NSTC 112-2221-E-324-010.

References

- [1] Mulla, A., Baviskar, J., Baviskar, A. & Bhovad, A., *GPS Assisted Standard Positioning Service for Navigation and Tracking: Review & Implementation*, Proc. International Conference on Pervasive Computing (ICPC), January 2015. doi: 10.1109/PERVASIVE.2015.7087165.
- [2] Chuhhakam, P., Pummardin, P., Jeen-im, P., Wardkien, P., Wisartpong, P. & Lertteerada, K., *GPS Position Predicting System by Kalman Filter with Velocity from OBD and Direction from Magnetometer*, Proc. 9th International Electrical Engineering Congress (IEECON), pp. 444-447, 2021.
- [3] Kaewket, P. & Sukvichai, K., *Investigate GPS Signal Loss Handling Strategies for a Low Cost Multi-GPS system based Kalman Filter*, Proc. 19th International Conference on Electrical Engineering/Electronics, Computer, Telecommunications and Information Technology (ECTI-CON), pp. 1-4, 2022.
- [4] Abidin, H.Z., Andreas, H., Gamal, M., Surono & Hendrasto, M., *Studying Landslide Displacements in Megamendung (Indonesia) Using GPS Survey Method*, Journal of Engineering and Technological Sciences, **36**(2), pp.109-123, 2004.
- [5] Vo, Q.D. & De, P., *A Survey of Fingerprint-Based Outdoor Localization*, IEEE Comm. Surveys & Tutorials, **18**(1), pp. 491–506, 2015.
- [6] Garvanov, I. & Garvanova, M., *Improving GPS Positioning of Vehicles in Urban Environment*, Proc. 21st International Symposium on Electrical Apparatus & Technologies (SIELA), pp. 1-5, 2020.
- [7] Shi, Z., Deng, Z., Zheng, W. & Li, N., *Campus Indoor and Outdoor Positioning System based on GPS and Wi-Fi*, Proc. 9th International Conference on Dependable Systems and Their Applications (DSA), pp. 903-908, 2022.
- [8] Fascista, A., De Monte, A., Coluccia, A., Wymeersch, H. & Seco-Granados, G., *Low-Complexity Downlink Channel Estimation in mmWave Multiple-Input Single-Output Systems*, IEEE Wireless Communications Letters, **11**(3), pp. 518-522, 2022.
- [9] Wen, F., Wymeersch, H., Peng, B., Tay, W.P., So, H.C. & Yang, D., *A Survey on 5G Massive MIMO Localization*, Digital Signal Processing, **94**, pp. 21-28, 2019.
- [10] Fascista, A., Coluccia, A., Wymeersch, H. & Seco-Granados, G., *Downlink Single-Snapshot Localization and Mapping with a Single-Antenna Receiver*, IEEE Transactions on Wireless Communications, **20**(7), pp. 4672-4684, 2021.
- [11] Maqsood, B. & Naqvi, I.H., *Sub-Nyquist Rate UWB Indoor Positioning Using Power Delay Profile and Time of Arrival Estimates*, Proc. IEEE 86th Vehicular Technology Conference (VTC-Fall), pp. 1-5, 2017.
- [12] Makki, A., Siddig, A., Saad, M., Cavallaro, J.R. & Bleakley, C.J., *Indoor Localization Using 802.11 Time Differences of Arrival*, IEEE Trans. Instrumentation and Measurement, **65**(3), pp. 614-623, 2016.
- [13] Chugunov, A., Petukhov, N. & Kulikov, R., *ToA Positioning Algorithm for TDoA System Architecture*, Proc. International Russian Automation Conference (RusAutoCon), pp. 871-876, 2020.
- [14] Ahmed, S., Abbasi, A. & Liu, H., *A Novel Hybrid AoA and TDoA Solution for Transmitter Positioning*, Proc. International Conference on Indoor Positioning and Indoor Navigation (IPIN), pp. 1-7, 2021.
- [15] Bnilam, N., Ergeerts, G., Subotic, D., Steckel, J. & Weyn, M., *Adaptive Probabilistic Model Using Angle of Arrival Estimation for IOT Indoor Localization*, Proc. International Conference on Indoor Positioning and Indoor Navigation (IPIN), pp. 1-7, 2017.
- [16] Bnilam, N., Tanghe, E., Steckel, J., Joseph, W. & Weyn, M., *ANGLE: ANGular Location Estimation Algorithms*, IEEE Access, **8**, pp. 14620-14629, 2020.
- [17] Alteneiji, A., Ahmad, U., Poon, K., Ali, N. & Almoosa, N., *Indoor Localization in Multi-Path Environment based on AoA with Particle Filter*, Proc. 3rd International Conference on Signal Processing and Information Security (ICSPIS), pp. 1-4, 2020.
- [18] Zhao, X. & Yang, Y., *An AOA Indoor Positioning System Based on Bluetooth 5.1*, Proc. 11th International Conference of Information and Communication Technology (ICTech), pp. 511-515, 2022.
- [19] Zhu, J.Y., Zheng, A.X., Xu, J. & Li, V.O., *Spatio-Temporal (S-T) Similarity Model for Constructing WIFI-Based RSSI Fingerprinting Map for Indoor Localization*, Proc. International Conference on Indoor Positioning and Indoor Navigation (IPIN), pp. 678-684, 2014.

- [20] Ezpeleta, S., Claver, J., Perez-Solano, J. & Marti-Aviles, J., *RF-Based Location Using Interpolation Functions to Reduce Fingerprint Mapping*, *Sensors*, **15**(10), pp. 27322-27340, 2015.
- [21] Ketabalian, H., Biguesh, M., & Sheikhi, A., *A Closed-Form Solution for Localization Based on RSS*, *IEEE Transactions on Aerospace and Electronic Systems*, **56**(2), pp. 912-923, 2020.
- [22] Yinjing, G., Xianqi, S., Lei, Y. & Wenhong, L., *A Coal Mine Underground Localization Algorithm Based on the Feature Vector*, *Journal of Engineering and Technological Sciences*, **51**(2), pp. 184-197, 2019.
- [23] Xue, W., *A New Weighted Algorithm Based on the Uneven Spatial Resolution of RSSI for Indoor Localization*, *IEEE Access*, **6**, pp. 26588-26595, 2018.
- [24] Zafari, F., Papapanagiotou, I. & Hacker, T.J., *A Novel Bayesian Filtering Based Algorithm for RSSI-Based Indoor Localization*, *Proc. IEEE International Conference Communications (ICC)*, pp. 1-7, 2018.
- [25] Tian, X., Wei, G. & Wang, J., *Target Location Method Based on Compressed Sensing in Hidden Semi Markov Model*, *Electronics*, **11**(11), pp. 1715, 2022.
- [26] Avendaño-Lopez, C.M., Castro-Sanchez, R., Almanza-Ojeda, D.L., Avina-Cervantes, J.G., Gomez-Martinez, M.A. & Ibarra-Manzano, M.A., *Scalable Visible Light Indoor Positioning System Using RSS*, *Mathematics*, **10**(10), 1738, 2022.
- [27] Sadowski, S. & Spachos, P., *RSSI-Based Indoor Localization with the Internet of Things*, *IEEE Access*, **6**, pp. 30149-30161, 2018.
- [28] Xue, W. Qiu, W., Hua, X. & Yu, K., *Improved Wi-Fi RSSI Measurement for Indoor Localization*, *IEEE Sensors Journal*, **17**(7), pp. 2224-2230, 2017.
- [29] Mahmud, M.I., Abdelgawad, A., Yanambaka, V.P. & Yelamarthi, K., *Packet Drop and RSSI Evaluation for LoRa: An Indoor Application Perspective*, *Proc. IEEE 7th World Forum on Internet of Things (WF-IoT)*, pp. 913-914, 2021.
- [30] Yao, L., Peng, X., Shi, D. & Liu, B., *Design of Indoor Positioning System Based on RSSI Algorithm*, *Proc. International Conference on Management Science and Software Engineering (ICMSSE)*, pp. 145-148, 2021.
- [31] Fascista, A., Coluccia, A. & Ricci, G., *A Pseudo Maximum Likelihood Approach to Position Estimation in Dynamic Multipath Environments*, *Signal Processing*, **181**, 107907, 2021.
- [32] Zhao, H., Huang, M. & Shen, Y., *High-Accuracy Localization in Multipath Environments via Spatio-Temporal Feature Tensorization*, *IEEE Transactions on Wireless Communications*, **21**(12), pp. 10576-10591, 2022
- [33] Fascista, A., Coluccia, A. & Ricci, G., *Direct Position Estimation of a Mobile Receiver in Multipath Environments via Adaptive Beamforming*, *28th European Signal Processing Conference (EUSIPCO)*, Amsterdam, Netherlands, pp. 1782-1786, 2021.
- [34] Tripura, J., Roy, P. & Barbhuiya, A.K., *Application of RBFNNs Incorporating MIMO Processes for Simultaneous River Flow Forecasting*, *Journal of Engineering and Technological Sciences*, **50**(3), pp.434-449, 2018.
- [35] Ushada, M., Wijayanto, T., Trapsilawati, F. & Okayama, T., *Modeling SMEs' Trust in the Implementation of Industry 4.0 using Kansei Engineering and Artificial Neural Network: Food and Beverage SMEs Context*, *Journal of Engineering and Technological Sciences*, **53**(2), 210203, 2021.
- [36] Nguyen, H., Phan, T., Dao, T., Phuc, P., Nguyen, C., Pham, N. & Huynh, H., *Gene Family Abundance Visualization based on Feature Selection Combined Deep Learning to Improve Disease Diagnosis*, *Journal of Engineering and Technological Sciences*, **53**(1), pp. 99-115, 2021.
- [37] Sanam, T.F. & Godrich, H., *An Improved CSI Based Device Free Indoor Localization Using Machine Learning Based Classification Approach*, *Proc. 26th European Signal Processing Conference (EUSIPCO)*, pp. 2390-2394, 2018.
- [38] Wang, Y., Xia, S., Tang, Q., Wu, J. & Zhu, X., *A Novel Consistent Random Forest Framework: Bernoulli Random Forests*, *IEEE Trans. Neural Networks and Learning Systems*, **29**(8), pp. 3510-3523, 2018.
- [39] Bicego, M. & Escolano, F., *On Learning Random Forests for Random Forest-clustering*, *Proc. 25th International Conference on Pattern Recognition (ICPR)*, pp. 3451-3458, 2021.
- [40] Cheng, C.H., Huang, Y.H. & Chen, H.C., *Enhanced Channel Estimation in OFDM Systems with Neural Network Technologies*, *Soft Computing*, **23**, pp. 5185-5197, 2019.
- [41] Dong, Z., Wu, C., Fu, X. & Wang, F., *Research and Application of Back Propagation Neural Network-Based Linear Constrained Optimization Method*, *IEEE Access*, **9**, pp. 126579-126594, 2021.

Manuscript Received: 19 November 2022

1st Revised Manuscript Received: 5 April 2023

2nd Revised Manuscript Received: 12 May 2023

Accepted Manuscript: 22 May 2023