



Challenges of Islamic Boarding School Organizational Culture in The Millennial Generation and The Digital Era 4.0

Abd. Muhith*¹, Yudo Dwiyo², Siti Munawati³, Ali Mustofa⁴, Sugeng Haryanto⁵

Universitas Islam Negeri Kh Achmad Siddiq Jember, Indonesia¹

Universitas Mulawarman, Samarinda Indonesia²

Universitas Islam Syekh Yusuf Tangerang Indonesia³

Sekolah Tinggi Ilmu Tarbiyah Al-Urwatul Wutsqo Jombang, Indonesia⁴

Universitas Merdeka Malang Indonesia⁵

Email correspondence: abdmuhith1972@gmail.com

Received: 11-07-2023

Revised: 23-10-2023

Accepted: 04-12-2023

Abstract

This research aims to determine the role of the digitalization era as an intervening variable among the millennial generation toward organizational culture in Islamic boarding schools. To find out this, a research question was created which was answered in a hypothesis or temporary research answer, namely that the millennial generation has a significant influence on the organizational culture of Islamic boarding schools. The second hypothesis is that the digital era has a positive and significant influence on organizational culture and the final hypothesis is that the millennial generation has a positive and significant influence on Islamic boarding school organizational culture through the digital era. This research is quantitative research with a survey method, where data is obtained through questionnaires that have been tested for validity and reliability. The research instrument uses a 1-5 Likert scale. In determining the sample from the population using probability sampling using path diagram analysis whose analysis uses structural equation modeling (SEM). The results of the research show that there is a significant influence between the millennial generation on organizational culture, secondly, the digital era has a positive and significant influence on organizational culture and the main finding in this research is that the digital era variable can mediate the millennial generation on organizational culture with its indicators.

Keywords: Millennial generation, digital era, organizational culture. Islamic boarding school.

Abstrak

Penelitian ini bertujuan untuk mengetahui peran era digitalisasi sebagai variabel lintervenien antara generasi milenial terhadap budaya organisasi di pondok pesantren. Untuk mengetahui hal tersebut maka dibuat pertanyaan penelitian yang dijawab dalam hipotesis atau jawaban sementara penelitian yaitu generasi milenial memiliki pengaruh signifikan terhadap budaya organisasi pesantren. Hipotesis kedua adalah era digital memiliki pengaruh positif dan signifikan terhadap budaya organisasi dan hipotesis yang terakhir adalah generasi milenial berpengaruh positif dan signifikan terhadap budaya organisasi pesantren melalui era digital. Penelitian ini merupakan penelitian kuantitatif dengan metode survey, dimana data yang diperoleh melalui kuesioner yang telah dilakukan uji validitas dan reliabilitas. Instrument penelitian menggunakan skala likert 1-5. Dalam menentukan sampel dari populasi menggunakan probability sampling dengan menggunakan analisis jalur path diagram yang analisis nya menggunakan structural equation modelling (SEM). Hasil penelitian menunjukkan bahwa terdapat pengaruh yang signifikan antara generasi milenial terhadap budaya organisasi, yang

kedua, era digital memiliki pengaruh positif dan signifikan terhadap budaya organisasi serta temuan utama dalam penelitian ini dimana variabel era digital mampu memediasi generasi milenial terhadap budaya organisasi dengan indikator-indikatornya.

Kata Kunci: *Generasi Milenial, era digital, budaya organisasi. Pondok pesantren*

INTRODUCTION

Currently, the millennial generation is the second largest in number after Generation Z.¹ Other data reveals that in Indonesia there are 48 million people, or the equivalent of 53% of workers coming from the millennial generation.² This millennial generation was born where technology started so it has a different character from previous generations. Technology that is so fast produces digitalization that is so fast. In an era full of rapid change and transformation, educational institutions, including Islamic boarding schools or Islamic schools and madrasas, are no exception to ongoing challenges. The millennial generation, which is now an integral part of society, is bringing major changes to various aspects of life, including education and organizational culture. Along with that, the entry of the digital era 4.0 has accelerated change through increasingly widespread use of technology and connectivity.

The millennial generation influences organizational culture as stated by Mayhara.³ The rigidity of organizational culture has a significant impact on the performance of the millennial generation.⁴ So it can be said that the millennial generation can influence organizational culture.⁵ There are three main indicators in the millennial generation, namely connected, confident, and creative.⁶ The characteristics of the millennial generation are 4: they have the desire to lead, can do several things, need balance and flexibility and millennials do not hesitate to leave jobs that do not make them happy.⁷ Islamic boarding schools, as traditional Islamic educational institutions in Indonesia, have a long, rich history of preserving religious and cultural values. However, the organizational culture challenges faced by Islamic boarding schools in accommodating the changes brought about by the millennial generation and the digital era 4.0 are an unavoidable reality. The digital era has a significant correlation with organizational culture, whereas in the era of digitalization, digital capabilities are a

¹ Yuli Nurhanisah, "Usia Muda Dominasi Penduduk Indonesia," *Indonesiabaik.id*, 2020.

² Gilang Maulani, "Tantangan Generasi Milenial dalam Dunia Kerja," *QuBisa*, 24 Januari 2023.

³ Siti Safira Mayhara, Yeni Absah, dan Amlis Syahputra Silalahi, "The Effect of Changes in Organisation and Organisation Culture towards Employee's Performance through Job Satisfaction of Millennials Generation in PT X North Sumatera Branch," *International Journal of Educational Review*, 2023, 1041–50.

⁴ Mohammad Reza, Rofiaty Rofiaty, dan Atim Djazuli, "The Influence of Situational Leadership, Organizational Culture and Training on Employee Performance and Work Motivation of Millennial Generation at the Inspection Office of BRI Malang," *Wacana* 21, no. 2 (2018): 89–95; Cahya Kurniawan dkk., "Factors influencing housing purchase decisions of millennial generation in Indonesia," *International Journal of Management* 11, no. 4 (2020): 350–65, <https://doi.org/10.34218/IJM.11.4.2020.035>.

⁵ Reza, Rofiaty, dan Djazuli, "The Influence of Situational Leadership, Organizational Culture and Training on Employee Performance and Work Motivation of Millennial Generation at the Inspection Office of BRI Malang."

⁶ Chairman and CEO Clifton, Jim, "How Millennials Want to Work and Live Purpose • Development • Coach • Ongoing Conversations • Strengths • Life THE SIX BIG CHANGES LEADERS HAVE TO MAKE," *Gallup*, 2016, 23.

⁷ Camille Kapoor and Nicole Solomon, "Understanding and managing generational differences in the workplace," *The Electronic Library* 3, no. 4 (2011): 308–19, <https://doi.org/10.1108/17554211111162435>.

fundamental predictor.⁸ One media organization in Denmark revealed that a good organizational culture transformation is using digital technology.⁹ Connecting digital with the environment and culture that is formed is not something easy.¹⁰ The digital era has 4 indicators which include being connected to the internet, use of gadgets or mobile devices, big data and analytics, and sophisticated technology.¹¹

A deep understanding of these changes in organizational culture is important, not only to maintain the relevance of Islamic education in a rapidly changing environment but also to develop appropriate strategies for dealing with them.¹² Organizational culture is the values that guide human resources in carrying out their obligations and behavior within the organization¹³. The characteristics of organizational culture at least consist of innovation and risk-taking courage, attention to detail, results orientation, people orientation, team orientation, aggressiveness, and stability. Islamic boarding school culture still focuses on kiai leadership.¹⁴ 3 indicators of Islamic boarding school organizational culture in general are religious and Islamic values, discipline and obedience, and academic and scientific development.¹⁵

This article aims to explore and analyze the challenges faced by Islamic boarding school organizational culture in facing the millennial generation and in adapting to the digital era 4.0. In addition, this article also seeks solutions that can help Islamic boarding schools overcome these challenges. Through a better understanding of this issue, it is hoped that Islamic boarding schools can remain effective Islamic educational institutions in shaping character and providing knowledge to the younger generation while maintaining deep Islamic traditions and values.

Based on the description above, a temporary answer or hypothesis can be drawn. The first hypothesis is that the millennial generation has a significant influence on the

⁸ Zhang Zhen dkk., "Nexus of digital organizational culture, capabilities, organizational readiness, and innovation: Investigation of smes operating in the digital economy," *Sustainability (Switzerland)* 13, no. 2 (2021): 1–15, <https://doi.org/10.3390/su13020720>; Natalia Trushkina dkk., *Digital Transformation of Organizational Culture Under Conditions of the Information Economy, Virtual Economics*, vol. 3, 2020, [https://doi.org/10.34021/ve.2020.03.01\(1\)](https://doi.org/10.34021/ve.2020.03.01(1)).

⁹ Sune Dueholm Müller dkk., "Digital innovation and organizational culture: The case of a danish media company," *Scandinavian Journal of Information Systems* 31, no. 2 (2019): 3–34.

¹⁰ Miri Shonfeld dkk., "Learning in digital environments: a model for cross-cultural alignment," *Educational Technology Research and Development* 69, no. 4 (2021): 2151–70, <https://doi.org/10.1007/s11423-021-09967-6>.

¹¹ Metty Paul dkk., "Digitization of healthcare sector: A study on privacy and security concerns," *ICT Express* 9, no. 4 (2023): 571–88, <https://doi.org/10.1016/j.ict.2023.02.007>; Leli Honesti dkk., "Innovation Utilization of Digital Applications Efforts to Improve College Achievement of Civil Engineering Students," 2012, 10383–92.

¹² Ari Kartiko dan Jaya Roza Azzukhrufi, "Pengaruh Budaya Organisasi Dan Kompensasi Terhadap Kinerja Pendidik Di Madrasah Aliyah Nahdlatul Ulama Mazro'atul Ulum Paciran," *Nidbomul Haq: Jurnal Manajemen Pendidikan Islam* 4, no. 2 (2019): 207–26, <https://doi.org/10.31538/ndh.v4i2.351>.

¹³ Stephen P. Robbins and Timothy A. Judge, *Perilaku Organisasi*, ed. oleh Ria Cahyani dan Abdul Rosyid Diana Angelica, Edisi 12 (Jakarta: Salemba Empat, 2008).

¹⁴ Siti Aisyah dkk., "Kiai Leadership Concept in The Scope of Pesantren Organizational Culture," *Tafkir: Interdisciplinary Journal of Islamic Education* 3, no. 1 (2022): 40–59, <https://doi.org/10.31538/tijie.v3i1.106>; Khalid Arar, Rania Sawalhi, dan Munube Yilmaz, "The Research on Islamic-Based Educational Leadership since," *Religions* 13, no. 42 (2022): 1–23; Abdul Karim dkk., "Altruistic works, religion, and corruption: Kiai s' leadership to shape anti-corruption values in pesantren ," *Cogent Social Sciences* 9, no. 1 (2023), <https://doi.org/10.1080/23311886.2023.2238968>.

¹⁵ Imron Arifin dkk., "Islamic Crash Course as a Leadership Strategy of School Principals in Strengthening School Organizational Culture," *SAGE Open* 8, no. 3 (2018), <https://doi.org/10.1177/2158244018799849>.

organizational culture of Islamic boarding schools. The second hypothesis is that the digital era has a positive and significant influence on organizational culture and the final hypothesis is that the millennial generation has a positive and significant influence on Islamic boarding school organizational culture through the digital era 4.0. This hypothesis will then be tested in the next section. Although many have conducted research on organizational culture, the millennial generation, and the digital era 4.0, not many have focused specifically on researching the millennial generation and digitalization and organizational culture in Islamic boarding schools. Apart from that, in previous research, no one has examined the digitalization era to be used as an intervening variable between the millennial generation variables and Islamic boarding school organizational culture.

METHOD

This research was conducted at the Modern Islamic Boarding School which is located in Mojokerto Regency over the period from January to April 2023. This research location was chosen because Mojokerto is the area that has the most modern Islamic boarding schools in Indonesia. This research uses quantitative research with a survey approach. This approach aims to collect numerical data that can be analyzed statistically to answer research questions or test hypotheses.¹⁶ The variables in this research are the millennial generation as an exogenous variable (X1), the digital era as an intervening variable (Y1), and Islamic boarding school organizational culture (Y2).

The data used in this research is primary data obtained directly from 198 respondents. The number of samples selected to be respondents used random selection techniques or random sampling. The data collection technique uses a questionnaire or questionnaire that contains questions or statements given and filled in directly by the respondent. Meanwhile, the instrument in this study uses a Likert scale of 1-5.¹⁷

To measure the validity of the data in this research through data validity and reliability tests. To test validity, use the correlation coefficient test by comparing the r-table and r-count values. The formula for the correlation coefficient is as follows:

$$r_{xy} = \frac{n\sum XY - (\sum X)(\sum Y)}{\sqrt{\{n\sum X^2 - (\sum X)^2\}\{n\sum Y^2 - (\sum Y)^2\}}}$$

Meanwhile, the reliability test uses the Cronbach alpha value.¹⁸ If the Cronbach alpha value is greater than 0.60, then it is declared reliable.

The analysis technique in this research uses structural equation model analysis. The steps in SEM analysis are to answer the hypothesis by developing a model based on concepts and theory, and constructing a path diagram as in Figure 1 below:

¹⁶ Suharsimi Arikunto, *Prosedur penelitian : suatu pendekatan praktik*, Ed. Rev 20 (Jakarta: Rineka Cipta, 2010).

¹⁷ Ankur Joshi dkk., "Likert Scale: Explored and Explained," *British Journal of Applied Science & Technology* 7, no. 4 (2015): 396–403, <https://doi.org/10.9734/bjast/2015/14975>; Rensis Likert, "The Method of Constructing an Attitude Scale" (Routledge, 1974).

¹⁸ Dodiet Aditya, "Modul Uji Validitas dan Reliabilitas Instrumen Penelitian," *Modul Statistika*, 2014, 1–12; Purwanto, *Teknik Penyusunan Instrumen Uji Validitas Dan Tealiabilitas Untuk Penelitian Ekonomi Syariah*, *Staiapress*, vol. 13, 2018.

Figure 1 Path Diagram

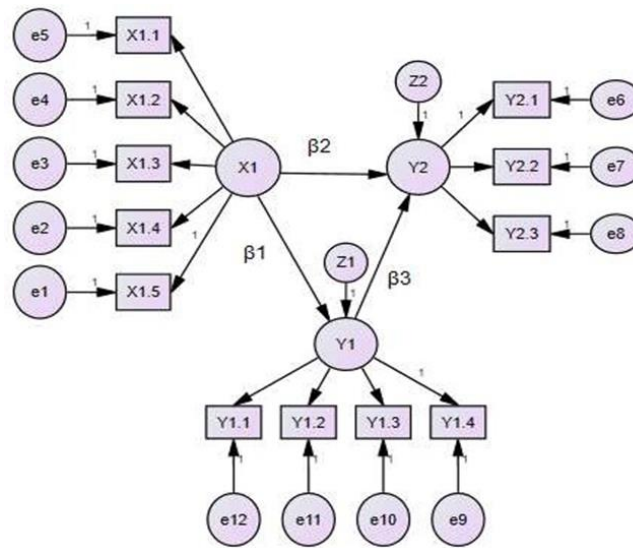

The next step after constructing the path diagram is converting the path diagram into a structural model, selecting the input matrix, and standard model solution and evaluating the goodness of fit index, for the final step, namely carrying out interpretation and modification if necessary. The regression equation model for the first hypothesis is $Y2 = \beta1X1 + Z1$. The regression equation for the second hypothesis is $Y2 = \beta1Y1 + Z2$, and the third hypothesis is If $\beta3 < \beta1$ then Y1 can mediate the effect of X1 on Y2.

RESULTS AND DISCUSSION

Findings

Based on the results of research testing the validity of all items, statements from each variable were declared valid because the calculated R-value was greater when compared to the Rtable value of 0.396. Meanwhile, the reliability test also obtained a Cronbach alpha value above 0.60, as seen in Table 1 below.

Table 1. Reliability Test Results

No	Variable	Cronbach alpha > 0.60	Information
1	Millennial Generation	0,763	reliable
2	Era of Digitalization	0,793	reliable
3	Organizational culture	0,733	reliable

Based on table 1, contains information about the results of Cronbach's alpha calculations for several variables used in research or studies. Cronbach's alpha is a statistical method used to measure the reliability or dependability of a questionnaire or measurement instrument. Cronbach's alpha value ranges from 0 to 1, and the higher the value, the higher the reliability. Usually, a value above 0.70 is considered good enough to measure the reliability of an instrument so that the instrument used in this research has a good level of reliability for all variables measured so that the measurement results obtained can be considered consistent and reliable in data analysis and interpretation.

The normality test results can be presented in Table 2, the following normality assumption test results :

Table 2 Normality Assumption Test Results

Variable	min	max	skew	c.r.	kurtosis	c.r.
Y11	4,000	5,000	-,873	-1,952	-1,238	-1,384
Y12	3,000	5,000	-,309	-,691	-,882	-,986
Y13	3,000	5,000	-,309	-,691	-,882	-,986
Y14	3,000	5,000	-,973	-2,176	-,098	-,110
Y23	3,000	5,000	-,604	-1,350	-1,261	-1,410
Y22	3,000	5,000	-,272	-,607	-1,114	-1,246
Y21	3,000	5,000	-,491	-1,098	-,643	-,719
X11	3,000	5,000	-,388	-,869	-,841	-,940
X12	3,000	5,000	-,561	-1,255	-,715	-,799
X13	3,000	5,000	-,563	-1,260	-,831	-,929
X14	2,000	5,000	-,126	-,281	-,567	-,634
X15	3,000	5,000	-,603	-1,348	-,574	-,642
Multivariate					30,662	4,581

The results of the normality test shows that all indicators in the variables studied have CR values between -2.58 and 2.58, so that all items in these variables are normally distributed. When the car value is in this range (-2.58 to 2.58), this indicates that the data distribution for all indicators in the variable is close to or follows a normal distribution. In this case, because all the items or indicators in the variable have CR values that comply with these limits, the conclusion is that all the variables are normally distributed. In other words, the data on the variable under study tends to have a distribution similar to a normal distribution or Gaussian curve, which is a basic assumption in many statistical analyses. This is important information because many statistical methods require the assumption that the data is normally distributed to provide valid results. With normality test results showing that the data is normally distributed, further statistical analysis can be carried out with confidence that this assumption has been met.

The results of the SEM Structural Confirmatory Factor Analysis test for Exogenous Variables show the following results, The loading factor values of the millennial generation variable indicators are X1.1 = 0.05, X1.2 = 0.25, X1.3 = 0.52, .87, X1.5 = 0.96. The overall factor loading value is > 0.50, this indicates that all of these indicators have a fairly strong (positive) relationship with the "millennial generation" variable. More specifically, they have a good level of contribution in measuring or describing millennial generation variables. Factor loading values above 0.50 indicate that these indicators have a strong positive correlation with the latent variable "millennial generation," and this strengthens the validity of measuring the millennial generation variable in the context of factor analysis. Confirmatory Factor Analysis of the intervening variables shows the following results: The factor loading values of the digital era variable indicators are Y1.1 = 0.93, Y1.2 = 0.96, Y1.3 = 0.94, Y1.4 = 0.98, which indicates that these indicators are highly relevant to the "digital era" variable and may cover important aspects of the concept. In factor analysis, high factor loading values like this also

indicate that these indicators can be relied on in measuring "digital era" variables and have a strong contribution to the understanding of these variables in the context of the research or analysis carried out and the results of the Confirmatory Factor Analysis Variable Endogenous shows the following results: The factor loading values for the organizational culture variable indicators are $Y2.1 = 0.99$, $Y2.2 = 0.99$, $Y2.3 = 0.99$, the factor loading values are very high and close to 1 for all indicators. ($Y2.1$, $Y2.2$, and $Y2.3$) indicate that these indicators have a very strong and positive relationship with the "organizational culture" variable. This shows that these indicators are very good at measuring or describing the "organizational culture" variable.

The results of the full structural model technique can be seen in Figure 1 path diagram below:

Figure 2. Path Diagram

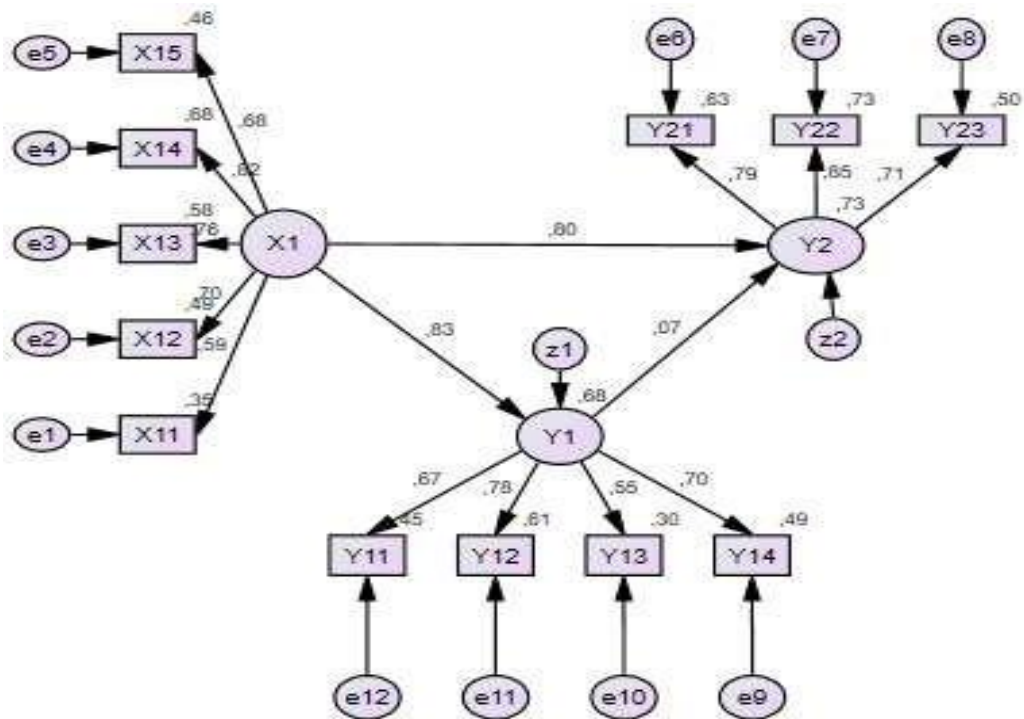

MODEL FIT
 Chi-square=60.642
 Probability=,167
 CMIN/DF=1,189
 GFI=,933
 AGFI=,898
 TLI=,984
 CFI=,988
 RMSEA=,036

Discussion

The Millennial Generation Has a Significant Influence on Islamic Boarding School Organizational Culture

Characteristics of millennial employees, who are characterized as the millennial generation born between 1980-2000, have a connected, confident, and creative character, which has an impact on organizational culture.¹⁹ Millennials tend to have a desire to play an active role in leadership and take initiative. They can be a motor of change in Islamic boarding schools by participating in the decision-making and management of the institution.²⁰ This can help in the innovation and development of Islamic boarding schools. The millennial generation tends to have the urge to play an active role in leadership. They not only want to be followers but also want to contribute to creating decisions that affect Islamic boarding schools. This means they can take on roles as leaders or active members in various committees and working groups. Millennials may push for increased transparency in Islamic boarding school management.²¹ They can encourage more open publication of information, including budgets, resource management, and performance evaluations. Overall, the millennial generation has the potential to bring positive change in Islamic boarding school organizational culture, by introducing fresh ideas, promoting collaboration, and carrying out initiatives that support the development of Islamic boarding schools in facing modern-day challenges.²²

The millennial generation has characteristics that can influence Islamic boarding school organizational culture, especially in terms of the desire to lead, flexibility, and balance between work and personal life. The desire to lead is the difference between the millennial generation and the millennial generation. This is based on several reasons, such as education which encourages creativity and high criticality. Many millennials grew up in an education system that encouraged creativity, criticality, and problem-solving. They are taught to think independently, solve problems, and contribute to groups. This shapes their attitudes towards innovation and active participation. Furthermore, access to information and connections means that the millennial generation is growing up in an era where access to information is very easy, especially via the Internet.²³ They can seek and explore new ideas, and connect with people who share similar views. This helps them feel more confident to participate in decision-making. The next reason is the need for meaning and impact, Millennials often look for meaning and impact in their work and life.²⁴ They want to feel that their contributions are

¹⁹ Gary Dessler, *Manajemen Sumber Daya Manusia*, 10 ed. (Jakarta: Indeks, 2011).

²⁰ Muhammad Abu Bakar, Khidriyah Amimatul Umroh, dan Fatima Hameed, "Improving Quality Islamic Education for Today's Generation," *At-Tadzkir: Islamic Education Journal* 2, no. 2 (26 Agustus 2023): 118–28, <https://doi.org/10.59373/attadzkir.v2i2.42>.

²¹ Melanie C. Brooks dan Miriam D. Ezzani, "Islamic school leadership: advancing a framework for critical spirituality," *International Journal of Qualitative Studies in Education* 35, no. 3 (16 Maret 2022): 319–36, <https://doi.org/10.1080/09518398.2021.1930265>.

²² Choirul Mahfud dkk., "Islamic cultural and Arabic linguistic influence on the languages of Nusantara; From lexical borrowing to localized Islamic lifestyles," *Wacana, Journal of the Humanities of Indonesia* 22, no. 1 (30 April 2021), <https://doi.org/10.17510/wacana.v22i1.914>.

²³ Rizkia Suciati dkk., "Millennial Students' Perception on the Integration of Islam and Science in Islamic Universities," *Indonesian Journal of Islam and Muslim Societies* 12, no. 1 (4 Juni 2022): 31–57, <https://doi.org/10.18326/ijims.v12i1.31-57>.

²⁴ Nathan Eva dkk., "Servant Leadership: A Systematic Review and Call for Future Research," *The Leadership Quarterly* 30, no. 1 (1 Februari 2019): 111–32, <https://doi.org/10.1016/j.leaqua.2018.07.004>.

meaningful and have a positive impact on the world. Therefore, they are more encouraged to play an active role in the organization and influence changes that they consider important. Tolerance of Differences and Inclusivity: Millennials tend to be more tolerant of differences and support inclusivity. They see value in diversity and a wide range of views. This makes them more likely to be open to fresh ideas from a variety of sources and want to ensure that decision-making reflects this diversity Social Awareness and Environmental Concern: Millennials often have a high level of social awareness and care about global issues, including the environment. This can encourage them to take an active role in organizations that promote the values they believe in, such as sustainability and ethics.²⁵

The millennial generation has high flexibility. This means that this generation tends to be more accepting and even seeking change, especially in terms of the way they work and the approaches taken in various aspects of life, including in the context of Islamic boarding schools. In the context of Islamic boarding schools, this has several implications that can be useful. These implications are like reforms in education.²⁶ The millennial generation may be more inclined to support reforms in the educational methods used in Islamic boarding schools. They may feel that traditional methods need to be updated or combined with modern approaches to be more efficient and effective in teaching Islamic values and science. Application of Technology, Millennials tend to be familiar with technology, and they can encourage Islamic boarding schools to adopt modern technology in educational, administrative, or communication processes. This can help Islamic boarding schools become more efficient and relevant in the digital era. Millennials also tend to seek flexibility in the way they work and participate in organizations. They may be more open to more inclusive management, where different views and roles are considered.²⁷ Quick Response to Challenges: Millennials often can respond quickly to challenges and changes that occur. In the context of Islamic boarding schools, this can help in addressing social, cultural, or economic changes that may affect the institution. Increasing the Relevance of Islamic Boarding Schools: With openness to change, the millennial generation can help Islamic boarding schools remain relevant in the modern era. This includes accommodating the developing needs of students and the community, as well as keeping Islamic boarding school values strong.²⁸

Millennials tend to seek a balance between work and personal life. They may be more likely to want free time to pursue personal interests, family, or religious activities. This could encourage Islamic boarding schools to pay more attention to this balance in their policies, such as providing more flexible holiday times. They want to have time to pursue personal

²⁵ Nurmawati Nurmawati, Cheri Julida Panjaitan, dan Khairul Amri, "Measurement of the Parenting Style of the Character of Millennial Students at State Islamic Higher Educational Institutions," *Jurnal Ilmiah Peuradeun* 10, no. 3 (30 September 2022): 685–98, <https://doi.org/10.26811/peuradeun.v10i3.712>; Luluk Asmawati, "The Development of Puzzle Games for Early Childhood Based on the Banten Local Culture," *Jurnal Ilmiah Peuradeun* 11, no. 2 (30 Mei 2023): 531–50, <https://doi.org/10.26811/peuradeun.v11i2.895>.

²⁶ Moh. Yamin, Hasan Basri, dan Andewi Suhartini, "Learning Management in Salaf Islamic Boarding Schools," *At-tadzkiir: Islamic Education Journal* 2, no. 1 (2023): 25–36, <https://doi.org/10.59373/attadzkiir.v2i1.10>.

²⁷ Andrea Amalia Salma, Zahrotuz Zakiyah, dan Zeti Pazita, "Views of Islamic Organizations on the Tradition of Not Slaughtering Cows in Kudus," *Dirasab International Journal of Islamic Studies* 1, no. 1 (2023): 27–35, <https://doi.org/10.59373/drs.v1i1.6>.

²⁸ Zuri Pamuji dan Fauzi Fauzi, "Service Innovation Model in Boarding School Programs for New Students at Islamic Higher Education," *Tajkiir: Interdisciplinary Journal of Islamic Education* 4, no. 2 (5 Juli 2023): 319–34, <https://doi.org/10.31538/tijie.v4i2.443>.

interests, interact with family, and engage in religious activities. In the context of Islamic boarding schools, this has several implications: Schedule Flexibility, Islamic boarding schools can consider providing more flexibility in their students' activity schedules, especially in allowing time for personal activities, such as worship and additional lessons. This can create a more balanced environment for students. Support for Religious Activities: Islamic boarding schools may be able to provide greater support for students' religious activities, including time for worship and additional religious study. This can meet the needs of students who want to deepen themselves in religion. Promotion of Mental Health and Well-Being: Providing more flexible free time can help in promoting the mental health and well-being of students. Islamic boarding schools can provide resources and support for students in maintaining a balance between academic work and personal life recognition of the Role of the Family: Islamic boarding schools can also recognize the importance of the role of the family in the lives of students. This could involve regulations allowing family visits or more open communication between students and their families.²⁹

Millennials generally don't hesitate to leave jobs that don't make them happy. In the context of Islamic boarding schools, this can encourage management to pay more attention to the satisfaction and welfare of students and staff. Islamic boarding schools that can create a positive and supportive environment will be more likely to retain students and employees. In the Islamic boarding school context, this has several implications: Attention to Santri Satisfaction: Islamic boarding schools can pay more attention to and measure the level of *Santri* satisfaction. This includes a deeper understanding of what makes students feel happy and satisfied in Islamic boarding schools, such as educational methods, services, and facilities. Increasing a Positive Environment: Islamic boarding schools that understand the importance of student satisfaction may make more efforts to create a positive, inclusive, and supportive environment. This can include a variety of initiatives, from improving facilities to improving communication and emotional support. Recruitment and Retention of Students and Employees, Islamic boarding schools that focus on student and employee satisfaction are more likely to be successful in recruitment and retention.³⁰ Happy *santri* are more likely to stay at the pesantren, and satisfied staff are more likely to stay working there. Increasing Islamic boarding schools that pay attention to student satisfaction tend to strive to improve the quality of education and experience of students. This could include developing relevant curricula, improving teacher training, and paying attention to the individual needs of students.

The research results in this section confirm previous research which states that the millennial generation influences changes and developments in organizational culture³¹, However, this research was not conducted in Islamic boarding school organizations.

²⁹ Erie Hariyanto dkk., "Sakinah Family Empowerment by Optimizing the Role of BP4 and Parents Mental Revolution Perspective," *Samarah: Jurnal Hukum Keluarga Dan Hukum Islam* 5, no. 2 (26 Desember 2021): 619–47, <https://doi.org/10.22373/sjhk.v5i2.10965>.

³⁰ Fitriyana Fitriyana dkk., "Servant Leadership and Perceived Organizational Support for Lecturer Loyalty Through Empowerment," *Tafkir: Interdisciplinary Journal of Islamic Education* 4, no. 1 (5 Maret 2023): 113–27, <https://doi.org/10.31538/tjie.v4i1.318>.

³¹ Syed Usman Qadri dkk., "Work Environment as a Moderator Linking Green Human Resources Management Strategies with Turnover Intention of Millennials: A Study of Malaysian Hotel Industry," *Sustainability (Switzerland)* 14, no. 12 (2022), <https://doi.org/10.3390/su14127401>; Ronald A. Lukens-Bull, "Two Sides of the Same Coin: Modernity and Tradition in Islamic Education in Indonesia," *Anthropology & Culture*

The digital era has a positive and significant influence on organizational culture

Widespread and fast access to the internet allows organizations to connect with more people around the world. This creates new opportunities to communicate with various stakeholders, gather input, and promote organizational values³². Organizational culture is becoming more open, inclusive, and global. The Internet allows organizations to connect with a variety of stakeholders, including organizational members, customers, business partners, and the wider community. This allows organizations to expand the reach of their messages and interactions. By connecting to more people around the world, organizations can more easily gather input and feedback from multiple sources. This can help in improving an organization's products, services, and policies. Organizations can promote their values and their goals more effectively via the Internet. They can use social media, websites, and other online platforms to spread their message and support their mission. The ability to communicate with multiple stakeholders from different backgrounds and geographic locations can help create a more inclusive and global organizational culture. Organizations can support diversity and promote universal values. The Internet allows organizations to build stronger networks with people who share similar interests, goals, or values. This can help in sharing knowledge, resources, and collaboration opportunities.

The use of mobile devices allows organizational members to stay connected and communicate without geographic restrictions. It facilitates remote collaboration, speeds up the exchange of information, and enables access to productivity tools that improve efficiency and flexibility. Organizational culture becomes more adaptive and open to technological change. Mobile devices allow organizational members to connect anytime and anywhere, without being limited by physical location. This is especially important in the era of globalization, where organizations often have members or branches spread across various geographic locations. With mobile devices, organizational members can collaborate effectively even if they are in remote locations. They can share information, work together on projects, and communicate through various online collaboration platforms, such as instant messaging applications and cloud-based collaboration tools. Mobile devices enable real-time exchange of information. This speeds up communication and decision-making within the organization. Critical information can be accessed and shared quickly, which in turn increases the organization's responsiveness to changing market and customer needs. Mobile devices also bring a variety of productivity tools to the fingertips of organizational members. With productivity apps, they can access documents, calendars, and other work tools from their devices, improving efficiency and flexibility in carrying out daily tasks. The use of mobile devices reflects the need for flexibility in the way of working. Organization members have greater access to determine when and where they work, which fits the trend of flexibility needs of generations such as millennials. The impact of using mobile devices is a change in

glyph="@amp;" ascii="&"/> *Education Quarterly* 32, no. 3 (2001): 350–72, <https://doi.org/10.1525/aeq.2001.32.3.350>.

³² Kardi Kardi dkk., “Challenges of Online Boarding Schools In The Digital Era,” *At-tadzkiir: Islamic Education Journal* 2, no. 1 (2023): 37–51, <https://doi.org/10.59373/attadzkiir.v2i1.11>; Joep Cornelissen, *Corporate Communication: A Guide to Theory and Practice, Corporate Communication: A Strategic ...*, 2011.

organizational culture. Organizations that adopt mobile devices and encourage technology-based communication and collaboration tend to have a culture that is more adaptive, open to technological change, and responsive to the needs of organizational members.

The use of big data and analytics allows organizations to collect, analyze, and understand data better. This can help in smarter decision-making, increased operational efficiency, and a deeper understanding of organizational members and customers. Organizational culture is becoming more evidence-based and fact-oriented. Big data allows organizations to collect data from various sources, including internal organizational data, customer data, social media data, and other external data. This creates a more comprehensive understanding of various aspects of the business and stakeholders. Analytics allow organizations to dig into that data and gain deeper insights. With sophisticated analytical tools, organizations can identify trends, patterns, and relationships that may not be visible to the naked eye. With powerful data and in-depth analysis, organizations can make smarter and more informed decisions. Decisions based on evidence and data tend to be more effective and have a more positive impact. Leveraging data and analytics can create a more evidence-oriented organizational culture. Decisions and steps taken are supported by strong data and analysis. This creates a more objective and fact-focused approach to managing the organization. With a deep understanding of trends and changes in data, organizations can become more responsive to changes in markets, customer needs, and the business environment. This allows organizations to stay relevant and adapt quickly.

Leveraging advanced technologies such as artificial intelligence (AI) and the Internet of Things (IoT) allows organizations to automate routine tasks, identify trends and provide more personalized services. This can increase productivity, free up human resources for creative tasks, and increase organizational member satisfaction. Organizational culture becomes more innovative and focused on results.

In organizational culture, the digital era can create positive changes by increasing communication, collaboration and adaptability. Organizations that are open to new technologies and committed to utilizing them effectively can create an environment that is more dynamic, efficient and oriented towards achieving common goals. This helps organizations to stay relevant in an ever-changing and competitive world. The digital era allows organizations to communicate more efficiently and effectively, both internally and externally. The use of email, instant messaging applications, social media, and other communication tools allows for faster and easier exchange of information. This creates better relationships between members of the organization and with customers and external stakeholders. With collaboration technologies such as cloud-based platforms, video conferencing, and document sharing tools, organizations can facilitate more efficient team collaboration, even if team members are located far apart. This allows achieving common goals more effectively.

Organizations that are open to new technologies and committed to utilizing them effectively tend to be more adaptive to change. They are able to respond to changes in markets, technology and business trends more quickly and flexibly. With business process automation, data analysis, and productivity tools, organizations can increase operational efficiency. This leads to cost savings, resource optimization, and increased productivity.

The digital era has a positive and significant influence on organizational culture, reinforcing previous research conducted by Azem et al, which revealed that the digital era requires everyone in the organization to move toward innovation.³³ Apart from that, Wekke and Hamid in their research revealed that Islamic boarding schools can approve that they have two sides as a source of learning to shape generations to reach the world, and technology has an important role in the current era.³⁴

The Millennial Generation Has a Positive and Significant Influence on Islamic Boarding School Organizational Culture Through the Digital Era 4.0

The millennial generation has great potential to have a positive influence on Islamic boarding school organizational culture. They are a generation that grew up with digital technology and have different perspectives on various aspects of life, including education and religion. The millennial generation's ability to adapt to advanced technology and their understanding of how to use this technology can help shape a more dynamic and relevant organizational culture. Fiction reveals that the millennial generation grew up in the era of digital technology and has a deep understanding of technology³⁵. Their ability to understand and use this technology can help Islamic boarding schools modernize their organizational culture. This may include the use of modern software and equipment in teaching, administration, and internal communications. The millennial generation can help Islamic boarding schools to be more effective in conveying religious and educational values to the younger generation.³⁶ They can use digital technology to spread religious messages, organize religious activities, and facilitate more open and interactive discussions. The millennial generation can help Islamic boarding schools remain relevant in the face of current developments, make Islamic boarding school organizational culture more appropriate to the needs of the younger generation growing up in the digital era, and optimize religious education and religious values conveyed to the younger generation.³⁷

Digital Era 4.0 is a term that refers to the development of digital technology involving artificial intelligence, the Internet of Things (IoT), big data, and high connectivity. The millennial generation can utilize this technology to create a significant impact on Islamic boarding school organizational culture. They can integrate this technology into Islamic

³³ Muhammad Azeem dkk., "Expanding competitive advantage through organizational culture, knowledge sharing and organizational innovation," *Technology in Society* 66, no. January (2021): 101635, <https://doi.org/10.1016/j.techsoc.2021.101635>.

³⁴ Ismail Suardi Wekke dan Sanusi Hamid, "Technology on Language Teaching and Learning: A Research on Indonesian Pesantren," *Procedia - Social and Behavioral Sciences* 83 (2013): 585–89, <https://doi.org/10.1016/j.sbspro.2013.06.111>; J Shaturayev, "Indonesia: Superior Policies and Management for Better Education (Community development through Education)," *Архив Научных Исследований*, no. 20 (2021): 1–10.

³⁵ Urban Fiction, "Critical Readings : African American Girls," *Journal of Adolescent & Adult literacy* 53, no. April (2010): 565–74, <https://doi.org/10.1598/JA>.

³⁶ Sa'dullah Assa'idi, "The Growth of Pesantren in Indonesia as the Islamic Venue and Social Class Status of Santri," *Eurasian Journal of Educational Research*, 2021, <https://eric.ed.gov/?id=EJ1300132>.

³⁷ Syahrul Ode Aliani dkk., "The Role of Islamic Religious Counselors in Providing Religious Understanding of Ta'lim Councils in Minority Areas," *Dirasah International Journal of Islamic Studies* 1, no. 2 (29 Oktober 2023): 89–101, <https://doi.org/10.59373/drs.v1i2.19>; Muhammad Alqadri Burga dan Muljono Damopolii, "Reinforcing Religious Moderation through Local Culture-Based Pesantren," *Jurnal Pendidikan Islam* 8, no. 2 (31 Desember 2022): 145–62, <https://doi.org/10.15575/jpi.v8i2.19879>.

boarding school education, management, and communication. The significant influence of the Digital Era 4.0 refers to the millennial generation's ability to use this advanced technology to improve the organizational culture of Islamic boarding schools. This includes innovations in education, management, and communication, which can ultimately improve the efficiency and quality of Islamic boarding schools and keep them relevant in the ever-evolving digital era.³⁸

The millennial generation through the digital era 4.0 can help in transforming Islamic boarding school organizational culture.³⁹ They can promote the use of technology in the educational process, improve communication with students and stakeholders, and create an inclusive and innovation-oriented culture. This cultural transformation can help Islamic boarding schools remain relevant in the modern era and meet the needs of the younger generation. The implications of the transformation of Islamic boarding school organizational culture are the integration of technology, improved communication through digital communication, an inclusive culture, orientation towards innovation, and relevance to the modern era. Use of Technology for Religious Education: The digital era allows Islamic boarding schools to use technology in religious education. The millennial generation can play a role in designing interesting and informative digital educational content, as well as integrating technology into the learning process to make it more effective.

Connecting Santri and Online Communities: Millennials can use social media and online platforms to connect *santri* with the larger community and support the exchange of experiences, ideas, and support. This helps Islamic boarding schools to create stronger communities in the digital world. Transmitting Islamic Boarding School Messages and Values: The millennial generation can help Islamic boarding schools spread the messages and values they adhere to to a wider audience through online platforms. This creates awareness about Islamic boarding schools and can attract the interest of people who may not have been involved before.⁴⁰ Overall, the millennial generation, when given support and space to contribute, can have a significant impact on Islamic boarding school organizational culture through the use of the digital era 4.0. They bring energy, fresh ideas, and technological knowledge that can help Islamic boarding schools become more dynamic, relevant, and adaptive in facing changing times.

The ability of the digital era to mediate the millennial generation on organizational culture is an important finding in this research because no previous researchers have

³⁸ Chatia Hastasari, Benni Setiawan, dan Suranto Aw, "Students' communication patterns of islamic boarding schools: the case of Students in Muallimin Muhammadiyah Yogyakarta," *Helijon* 8, no. 1 (2022): e08824, <https://doi.org/10.1016/j.helijon.2022.e08824>; Eka Fitria Fidayani dan Farikh Marzuki Ammar, "The Use of Azhari Curriculum in Arabic Language Learning at Islamic Boarding School," *Nazhruna: Jurnal Pendidikan Islam* 6, no. 1 (9 Januari 2023): 25–45, <https://doi.org/10.31538/nzh.v6i1.2866>.

³⁹ Imron Arifin dkk., "Islamic Crash Course as a Leadership Strategy of School Principals in Strengthening School Organizational Culture," *SAGE Open* 8, no. 3 (1 Juli 2018): 2158244018799849, <https://doi.org/10.1177/2158244018799849>; Dayang Rafidah Syariff M. Fuad, Khalip Musa, dan Zahari Hashim, "Innovation Culture in Education: A Systematic Review of the Literature," *Management in Education* 36, no. 3 (1 Juli 2022): 135–49, <https://doi.org/10.1177/0892020620959760>.

⁴⁰ Mahrus As'ad, "Implementing Life Skill Education in an Environment-Based Pesantren," *Jurnal Pendidikan Islam* 8, no. 1 (30 Juni 2022): 15–24, <https://doi.org/10.15575/jpi.v8i1.18253>; Mujahid Ansori, "Pengembangan Kurikulum Madrasah Di Pesantren," *Munaddhomah: Jurnal Manajemen Pendidikan Islam* 1, no. 1 (2020): 41–50, <https://doi.org/10.31538/munaddhomah.v1i1.32>.

conducted research that places the digital era as an intervening variable between the millennial generation and organizational culture.

CONCLUSION

The conclusion from this statement is that the millennial generation has characteristics that have a positive impact on Islamic boarding school organizational culture, especially through the use of the digital era 4.0. They tend to have a desire to play an active role in leadership, take initiative, and utilize digital technology for positive transformation in Islamic boarding schools. This generation encourages innovation, collaboration, and adaptability, as well as focusing on student and staff satisfaction. With the support of modern technology, they play a key role in making Islamic boarding schools more dynamic, relevant, and responsive to changing times.

Theoretically, this research can be a reference for future researchers because the findings of this research are that the digital era can act as an intermediary that connects the millennial generation with Islamic boarding school culture, which makes this research different from previous research, besides those previous researchers did not concentrate on Islamic boarding schools or Islamic education. Meanwhile, practically, Islamic boarding school managers can make small changes to accommodate the advantages of the millennial generation.

REFERENCES

- Aditya, Dodiet. "Modul Uji Validitas dan Reliabilitas Instrumen Penelitian." *Modul Statistika*, 2014, 1–12.
- Aisyah, Siti, Munaya Ulil Ilmi, Muhammad Amirudin Rosyid, Eni Wulandari, dan Fandi Akhmad. "Kiai Leadership Concept in The Scope of Pesantren Organizational Culture." *Tafkir: Interdisciplinary Journal of Islamic Education* 3, no. 1 (2022): 40–59. <https://doi.org/10.31538/tijie.v3i1.106>.
- Aliani, Syahrul Ode, Md Shabbir Alam, Ainur Rofiq, dan Fuad Srinio. "The Role of Islamic Religious Counselors in Providing Religious Understanding of Ta'lim Councils in Minority Areas." *Dirasab International Journal of Islamic Studies* 1, no. 2 (29 Oktober 2023): 89–101. <https://doi.org/10.59373/drs.v1i2.19>.
- Ansori, Mujahid. "Pengembangan Kurikulum Madrasah Di Pesantren." *Munaddhomah: Jurnal Manajemen Pendidikan Islam* 1, no. 1 (2020): 41–50. <https://doi.org/10.31538/munaddhomah.v1i1.32>.
- Arar, Khalid, Rania Sawalhi, dan Munube Yilmaz. "The Research on Islamic-Based Educational Leadership since." *Religions* 13, no. 42 (2022): 1–23.
- Arifin, Imron, Juharyanto, Mustiningsih, dan Ahmad Taufiq. "Islamic Crash Course as a Leadership Strategy of School Principals in Strengthening School Organizational Culture." *SAGE Open* 8, no. 3 (2018). <https://doi.org/10.1177/2158244018799849>.
- . "Islamic Crash Course as a Leadership Strategy of School Principals in Strengthening School Organizational Culture." *SAGE Open* 8, no. 3 (1 Juli 2018): 2158244018799849. <https://doi.org/10.1177/2158244018799849>.
- Arikunto, Suharsimi. *Prosedur penelitian : suatu pendekatan praktik*. Ed. Rev 20. Jakarta: Rineka Cipta, 2010.

- As'ad, Mahrus. "Implementing Life Skill Education in an Environment-Based Pesantren." *Jurnal Pendidikan Islam* 8, no. 1 (30 Juni 2022): 15–24. <https://doi.org/10.15575/jpi.v8i1.18253>.
- Asmawati, Luluk. "The Development of Puzzle Games for Early Childhood Based on the Banten Local Culture." *Jurnal Ilmiah Peuradeun* 11, no. 2 (30 Mei 2023): 531–50. <https://doi.org/10.26811/peuradeun.v11i2.895>.
- Assa'idi, Sa'dullah. "The Growth of Pesantren in Indonesia as the Islamic Venue and Social Class Status of Santri." *Eurasian Journal of Educational Research*, 2021. <https://eric.ed.gov/?id=EJ1300132>.
- Azeem, Muhammad, Munir Ahmed, Sajid Haider, dan Muhammad Sajjad. "Expanding competitive advantage through organizational culture, knowledge sharing and organizational innovation." *Technology in Society* 66, no. January (2021): 101635. <https://doi.org/10.1016/j.techsoc.2021.101635>.
- Bakar, Muhammad Abu, Khidriyah Amimatul Umroh, dan Fatima Hameed. "Improving Quality Islamic Education for Today's Generation." *At-Tadzkiir: Islamic Education Journal* 2, no. 2 (26 Agustus 2023): 118–28. <https://doi.org/10.59373/attadzkiir.v2i2.42>.
- Brooks, Melanie C., dan Miriam D. Ezzani. "Islamic school leadership: advancing a framework for critical spirituality." *International Journal of Qualitative Studies in Education* 35, no. 3 (16 Maret 2022): 319–36. <https://doi.org/10.1080/09518398.2021.1930265>.
- Burga, Muhammad Alqadri, dan Muljono Damopolii. "Reinforcing Religious Moderation through Local Culture-Based Pesantren." *Jurnal Pendidikan Islam* 8, no. 2 (31 Desember 2022): 145–62. <https://doi.org/10.15575/jpi.v8i2.19879>.
- Clifton, Jim, Chairman and CEO. "How Millennials Want to Work and Live Purpose • Development • Coach • Ongoing Conversations • Strengths • Life THE SIX BIG CHANGES LEADERS HAVE TO MAKE." *Gallup*, 2016, 23.
- Cornelissen, Joep. *Corporate Communication: A Guide to Theory and Practice. Corporate Communication: A Strategic ...*, 2011.
- Dessler, Gary. *Manajemen Sumber Daya Manusia*. 10 ed. Jakarta: Indeks, 2011.
- Eva, Nathan, Mulyadi Robin, Sen Sendjaya, Dirk van Dierendonck, dan Robert C. Liden. "Servant Leadership: A Systematic Review and Call for Future Research." *The Leadership Quarterly* 30, no. 1 (1 Februari 2019): 111–32. <https://doi.org/10.1016/j.leaqua.2018.07.004>.
- Fiction, Urban. "Critical Readings : African American Girls." *Journal of Adolescent & Adult literacy* 53, no. April (2010): 565–74. <https://doi.org/10.1598/JA>.
- Fidayani, Eka Fitria, dan Farikh Marzuki Ammar. "The Use of Azhari Curriculum in Arabic Language Learning at Islamic Boarding School." *Nazhruna: Jurnal Pendidikan Islam* 6, no. 1 (9 Januari 2023): 25–45. <https://doi.org/10.31538/nzh.v6i1.2866>.
- Fitriyana, Fitriyana, Henny Widya Astuti, Abdul Rahman, Rini Werdiningsih, dan Syech Idrus. "Servant Leadership and Perceived Organizational Support for Lecturer Loyalty Through Empowerment." *Tafkir: Interdisciplinary Journal of Islamic Education* 4, no. 1 (5 Maret 2023): 113–27. <https://doi.org/10.31538/tijie.v4i1.318>.
- Fuad, Dayang Rafidah Syariff M., Khalip Musa, dan Zahari Hashim. "Innovation Culture in Education: A Systematic Review of the Literature." *Management in Education* 36, no. 3 (1 Juli 2022): 135–49. <https://doi.org/10.1177/0892020620959760>.
- Hariyanto, Erie, Abd Hannan, Arif Wahyudi, Eka Susylawati, dan Bhismodi Tri Wahyu Faizal. "Sakinah Family Empowerment by Optimizing the Role of BP4 and Parents Mental Revolution Perspective." *Samarah: Jurnal Hukum Keluarga Dan Hukum Islam* 5, no. 2 (26 Desember 2021): 619–47. <https://doi.org/10.22373/sjhc.v5i2.10965>.

- Hastasari, Chatia, Benni Setiawan, dan Suranto Aw. "Students' communication patterns of islamic boarding schools: the case of Students in Muallimin Muhammadiyah Yogyakarta." *Heliyon* 8, no. 1 (2022): e08824. <https://doi.org/10.1016/j.heliyon.2022.e08824>.
- Honesti, Leli, Edison Hatoguan Manurung, Charles Sitindaon, dan Muji Indarwanto. "Innovation Utilization of Digital Applications Efforts to Improve College Achievement of Civil Engineering Students," 2012, 10383–92.
- Joshi, Ankur, Saket Kale, Satish Chandel, dan D. Pal. "Likert Scale: Explored and Explained." *British Journal of Applied Science & Technology* 7, no. 4 (2015): 396–403. <https://doi.org/10.9734/bjast/2015/14975>.
- Judge, Stephen P. Robbins and Timothy A. *Perilaku Organisasi*. Disunting oleh Ria Cahyani dan Abdul Rosyid Diana Angelica. Edisi 12. Jakarta: Salemba Empat, 2008.
- Kardi, Kardi, Hasan Basri, Andewi Suhartini, dan Fitri Meliani. "Challenges of Online Boarding Schools In The Digital Era." *At-tadzkiir: Islamic Education Journal* 2, no. 1 (2023): 37–51. <https://doi.org/10.59373/attadzkiir.v2i1.11>.
- Karim, Abdul, Oman Fathurrohman, Muhammadun, Wahyu Saripudin, Diding Rahmat, dan Firman Mansir. "Altruistic works, religion, and corruption: Kiai s' leadership to shape anti-corruption values in pesantren." *Cogent Social Sciences* 9, no. 1 (2023). <https://doi.org/10.1080/23311886.2023.2238968>.
- Kartiko, Ari, dan Jaya Roza Azzukhrufi. "Pengaruh Budaya Organisasi Dan Kompensasi Terhadap Kinerja Pendidik Di Madrasah Aliyah Nahdlatul Ulama Mazro'atul Ulum Paciran." *Nidhomul Haq: Jurnal Manajemen Pendidikan Islam* 4, no. 2 (2019): 207–26. <https://doi.org/10.31538/ndh.v4i2.351>.
- Kurniawan, Cahya, Lina Cynthia Dewi, Weny Maulatsih, dan Willy Gunadi. "Factors influencing housing purchase decisions of millennial generation in Indonesia." *International Journal of Management* 11, no. 4 (2020): 350–65. <https://doi.org/10.34218/IJM.11.4.2020.035>.
- Likert, Rensis. "The Method of Constructing an Attitude Scale." Routledge, 1974.
- Lukens-Bull, Ronald A. "Two Sides of the Same Coin: Modernity and Tradition in Islamic Education in Indonesia." *Anthropology & Education Quarterly* 32, no. 3 (2001): 350–72. <https://doi.org/10.1525/aeq.2001.32.3.350>.
- Mahfud, Choirul, Rika Astari, Abdurrohman Kasdi, Muhammad Mu'ammarr, Muyasaroh Muyasaroh, dan Firdaus Wajdi. "Islamic cultural and Arabic linguistic influence on the languages of Nusantara; From lexical borrowing to localized Islamic lifestyles." *Wacana, Journal of the Humanities of Indonesia* 22, no. 1 (30 April 2021). <https://doi.org/10.17510/wacana.v22i1.914>.
- Maulani, Gilang. "Tantangan Generasi Milenial dalam Dunia Kerja." *QuBisa*, 24 Januari 2023.
- Müller, Sune Dueholm, Nikolaus Obwegeser, Jakob Vang Glud, dan Gunnar Johildarson. "Digital innovation and organizational culture: The case of a danish media company." *Scandinavian Journal of Information Systems* 31, no. 2 (2019): 3–34.
- Nurhanisah, Yuli. "Usia Muda Dominasi Penduduk Indonesia." *Indonesiabaik.id*, 2020.
- Nurmawati, Nurmawati, Cheri Julida Panjaitan, dan Khairul Amri. "Measurement of the Parenting Style of the Character of Millennial Students at State Islamic Higher Educational Institutions." *Jurnal Ilmiah Peuradeun* 10, no. 3 (30 September 2022): 685–98. <https://doi.org/10.26811/peuradeun.v10i3.712>.
- Pamuji, Zuri, dan Fauzi Fauzi. "Service Innovation Model in Boarding School Programs for New Students at Islamic Higher Education." *Tafkir: Interdisciplinary Journal of Islamic Education* 4, no. 2 (5 Juli 2023): 319–34. <https://doi.org/10.31538/tijie.v4i2.443>.

- Paul, Metty, Leandros Maglaras, Mohamed Amine Ferrag, dan Iman Almomani. "Digitization of healthcare sector: A study on privacy and security concerns." *ICT Express* 9, no. 4 (2023): 571–88. <https://doi.org/10.1016/j.ict.2023.02.007>.
- Purwanto. *Teknik Penyusunan Instrumen Uji Validitas Dan Tealiabilitas Untuk Penelitian Ekonomi Syariab. Staiapress*. Vol. 13, 2018.
- Qadri, Syed Usman, Muhammad Amjad Bilal, Mingxing Li, Zhiqiang Ma, Safwan Qadri, Chengang Ye, dan Fawad Rauf. "Work Environment as a Moderator Linking Green Human Resources Management Strategies with Turnover Intention of Millennials: A Study of Malaysian Hotel Industry." *Sustainability (Switzerland)* 14, no. 12 (2022). <https://doi.org/10.3390/su14127401>.
- Reza, Mohammad, Rofiaty Rofiaty, dan Atim Djazuli. "The Influence of Situational Leadership, Organizational Culture and Training on Employee Performance and Work Motivation of Millennial Generation at the Inspection Office of BRI Malang." *Wacana* 21, no. 2 (2018): 89–95.
- Safira Mayhara, Siti, Yeni Absah, dan Amlis Syahputra Silalahi. "The Effect of Changes in Organisation and Organisation Culture towards Employee's Performance through Job Satisfaction of Millennials Generation in PT X North Sumatera Branch." *International Journal of Educational Review*, 2023, 1041–50.
- Salma, Andrea Amalia, Zahrotuz Zakiyah, dan Zeti Pazita. "Views of Islamic Organizations on the Tradition of Not Slaughtering Cows in Kudus." *Dirasah International Journal of Islamic Studies* 1, no. 1 (2023): 27–35. <https://doi.org/10.59373/drs.v1i1.6>.
- Shaturaev, J. "Indonesia: Superior Policies and Management for Better Education (Community development through Education)." *Архив Научных Исследований*, no. 20 (2021): 1–10.
- Shonfeld, Miri, Megan Cotnam-Kappel, Miriam Judge, Carolyn Yeehan Ng, Jean Gabin Ntebutse, Sandra Williamson-Leadley, dan Melda N. Yildiz. "Learning in digital environments: a model for cross-cultural alignment." *Educational Technology Research and Development* 69, no. 4 (2021): 2151–70. <https://doi.org/10.1007/s11423-021-09967-6>.
- Solomon, Camille Kapoor and Nicole. "Understanding and managing generational differences in the workplace." *The Electronic Library* 3, no. 4 (2011): 308–19. <https://doi.org/10.1108/17554211111162435>.
- Suciati, Rizkia, Herawati Susilo, Abdul Gofur, Umie Lestari, dan Izza Rohman. "Millennial Students' Perception on the Integration of Islam and Science in Islamic Universities." *Indonesian Journal of Islam and Muslim Societies* 12, no. 1 (4 Juni 2022): 31–57. <https://doi.org/10.18326/ijims.v12i1.31-57>.
- Trushkina, Nataliia, Rafis Abazov, Natalia Rynkevych, dan Guzelya Bakhautdinova. *Digital Transformation of Organizational Culture Under Conditions of the Information Economy. Virtual Economics*. Vol. 3, 2020. [https://doi.org/10.34021/ve.2020.03.01\(1\)](https://doi.org/10.34021/ve.2020.03.01(1)).
- Wekke, Ismail Suardi, dan Sanusi Hamid. "Technology on Language Teaching and Learning: A Research on Indonesian Pesantren." *Procedia - Social and Behavioral Sciences* 83 (2013): 585–89. <https://doi.org/10.1016/j.sbspro.2013.06.111>.
- Yamin, Moh., Hasan Bastri, dan Andewi Suhartini. "Learning Management in Salaf Islamic Boarding Schools." *At-tadzkiir: Islamic Education Journal* 2, no. 1 (2023): 25–36. <https://doi.org/10.59373/attadzkiir.v2i1.10>.
- Zhen, Zhang, Zahid Yousaf, Magdalena Radulescu, dan Muhammad Yasir. "Nexus of digital organizational culture, capabilities, organizational readiness, and innovation: Investigation of smes operating in the digital economy." *Sustainability (Switzerland)* 13, no. 2 (2021): 1–15. <https://doi.org/10.3390/su13020720>.