

Innovative Approach to Minimize Balancing Weight in Railway Wheel Sets

Jeetender Singh Kushawaha

Indus Institute of Technology and Management, Bilhaur, Kanpur, 209202, INDIA

Article Info

Article history:

Received 6 November, 2024
Revised 14 November, 2024
Accepted 25 November, 2024

Keywords:

Balancing
Dynamic balancing
Balancing weight
Railway wheel
Wheel boring
Press fitting

ABSTRACT

This study elaborates the re-iterative, trial& error procedure adapted to reduce the excessive consumption of balancing weights in the railway wheel sets during wheel set assembling. The process involved MATLAB programming for dynamic balancing equations and CAD simulations to arrive at the solution. On the completion of the study and implementation of findings, the reduction in the consumption of balancing weight by 95.9% has been realized.

**Corresponding Author:*

Jeetender Singh Kushawaha
Former, Head, Department of Mechanical Engineering, Indus Institute of Technology and Management, Bilhaur, Kanpur, 209202, INDIA
Email: k.jitendrasingh@yahoo.com

1. INTRODUCTION

1.1. Need

The money saved is money generated, based on this phrase this study is performed at wheel, axle and brake disc assembly plant in one of the railway production units of India. It was observed that excessive consumption of external balancing weight is taking place and author could get the access to study the problem. The excessive balancing weight consumption resulted in the increased cost of assembling of wheel sets for in house coach production. The need was felt to work for reduction of balancing weight consumption. The study was performed using the statistical, mathematical analysis along with MATLAB programming for the dynamic balancing equations for simulating the position and quantification of the balancing weight to match with the actual position and quantity of the balancing weight.

1.2 Assembly procedure

In the rail wheel, axle and brake disc assembly plant, rail wheel, axle, bearing and brake discs are taken as raw products and custom assembled to match the specified press fit limits, for the assembled wheel sets. The wheel set assembly plant is fully automated wherein the manual loading for the axle, rail wheel, brake discs and bearings is performed to place these items on the feeding conveyors.

The various operations performed on the axle in chronological order are cleaning, loading on feeding conveyors, facing, initial surface turning, drilling, threading, identification marking, surface turning, surface grinding, magnetic particle crack detection, washing, automated dimension measurements and transfer for brake disc positioning.

The various operations performed on rail wheel in chronological order are cleaning, loading on feeding conveyors, boring to match the dimensions as per the in-coming axle to meet the specified press fit limits and transfer for positioning of the rail wheels on the axle.

The pre-positioned brake discs and rail wheels are press fitted with specified pressing pressure and the assembled wheel set is transferred for turning the wheel tread to specified dimensions as per the wheel profile.

The turned wheel set is transferred to balancing machine for performing the balancing test wherein external balancing weight are pasted at the specified position, of specified quantity as indicated by the balancing machine algorithm.

The balanced wheel sets are transferred further for fitment of the bearings and onward dispatch for further utilization in the bogie assembly.

2. OBSERVATIONS

The problem of excessive consumption of balancing weight needed to be sorted out and minimization of the balancing weights was to be achieved. The problem was analyzed and predictable points of deliberation were found to be eccentricity of axle, unbalancing of the brake discs, eccentricity in the rail wheel boring, un-balance introduced during the tread machining and balancing machine. The methodology to diagnose and solve the problem was planned and worked out in following steps.

2.1. Eccentricity of axle

The process of axle turning was scrutinized and found that the probability is negligible as the axles are measured for any eccentricity using a continuous rotation path for measurement.

2.2. Brake disc

The brake discs were checked for any deformation and no abnormality was observed.

2.3. Wheel boring machine

The rail wheel boring process was scrutinized and no abnormality was observed in the wheel boring machine.

2.4. Tread turning machine

The tread machining process was scrutinized. The rollers for holding and rolling mechanism of the tread turning machine were found to be un-evenly worn out, reaching up-to 1 mm. The excessive and abnormal noise was also observed during the operation of the machine.

2.5. Balancing machine

The observation was made that in average approximately 250 grams of external balancing weight was required to be pasted on each wheel set (The two wheels mounted on the axle along with brake discs) at the balancing machine to bring the wheel set balancing in the specified limits.

Based on these observations and the problem in hand it was concluded to go for deep study as the balancing weight of about 120 gram cannot be contributed by the tread turning machine independently, however it may provide the random variation in the quantity and position of the balancing weights.

3. The assumption

The assumption was made that there is a certain significant amount of eccentricity contributed by the wheel boring machine.

4. The methodology

The methodology adapted to arrive at the solution was re-iterative and combination of trial & error, here it is, deliberated in following steps:

4.1. Data collection

The data regarding the position and quantity of balancing weight required for bringing the balancing in the specified limit was tabulated for more 50 wheel sets. The variation in the quantity and angular position was found to be 50 grams and 30 degrees. The angular positions were measured relative to location on right side wheel. This provided quite randomness and difficulty in making the conclusions. So, the modification in the process was incorporated and the rail wheels were marked a certain indicator arrow on the web portion. Now, a certainty of position of the balancing weight was achieved and the position of the balancing weight could be marked in advance at the loading stage, with accuracy in the range of 20 degrees.

4.2. Mathematical modeling

The dynamic model of railway vehicle for weigh in motion methodology for railway tracks [1] initiated to further study on the problem in hand. MATLAB programming [2]-[5] of dynamic balancing equations was performed to study the impact of brake disc balancing and its angular positions; this was found to be negligible in relation to the requirement of balancing weight on the rail wheels. Figure 1, shows the complete assembled wheel set with bearings, it also indicates the locations of the planes considered for dynamic balancing equations.

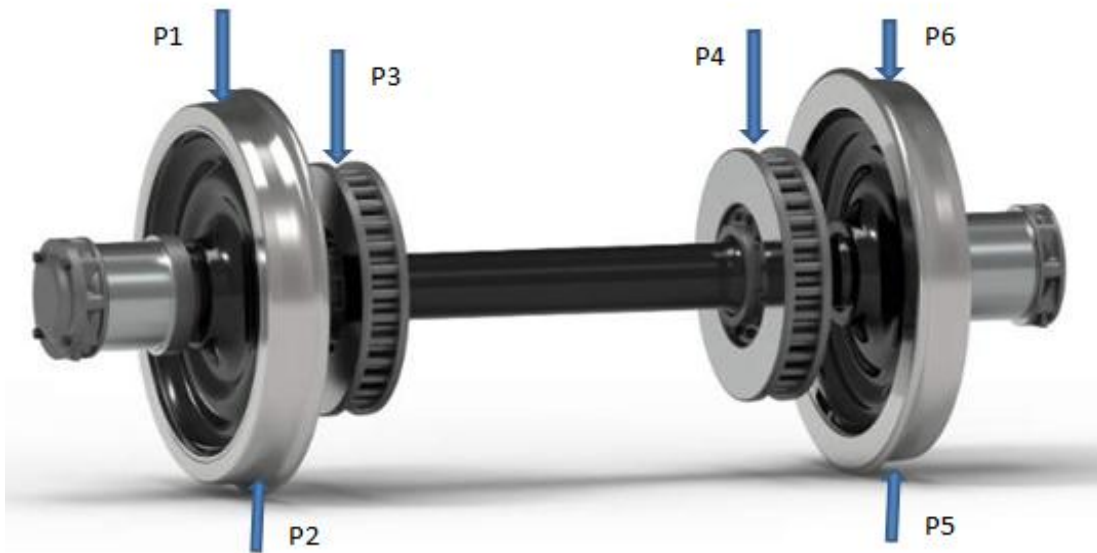

Figure 1. The complete wheel set with bearings

Six planes were considered to simulate the requirement of balancing weights. The planes passing through point of contact of tread and mid points of the brake disc were considered as reference planes P1, P3, P4, and P6, these were assumed to be containing the out of balance masses, m_1, m_2, m_3, m_4 . The planes P2 and P5 were located based upon the location of the fixing of counter balancing weights m_{c1} and . The following equations for complete dynamic balancing were used, in reference to the book by S.S. Rattan [6],

$$\sum mr + m_{c1}r_{c1} + m_{c2}r_{c2} = 0 \quad (1)$$

$$\sum mrl + m_{c2}r_{c2}l_{c2} = 0 \quad (2)$$

To find the angular positions of the counter balancing weights the following equations were derived from equation (1) and (2):

$$\tan \theta_{c2} = \frac{-\sum mr \sin \theta}{-\sum mr \cos \theta} \quad (3)$$

$$\tan \theta_{c1} = \frac{-(\sum mr \sin \theta + m_{c2}r_{c2} \sin \theta_{c2})}{-(\sum mr \cos \theta + m_{c2}r_{c2} \cos \theta_{c2})} \quad (4)$$

The r, l and θ indicates the radius, distance of plane of rotation from reference plane and angular position of the unbalancing/ counter balancing weights and subscript c refers to counter balancing weights. The equations were iteratively solved with various combinations of unbalancing weights. The solutions to the equations indicated that there was certain relation with the practically required balancing weights and there exists some eccentricity in the rail wheel.

4.2. Verification

The MATLAB code was composed and a test example, 14.3 was solved, for verification of MATLAB code, from reference [6] for the required balancing mass. The angular distribution and the required balancing masses are graphically represented in the figure 2. The screen shot of result of the MATLAB code is presented in figure 3. Based on the accuracy of these results, equations were developed and solved for our problem and re-iterative work was done to find the solutions to problem in hand.

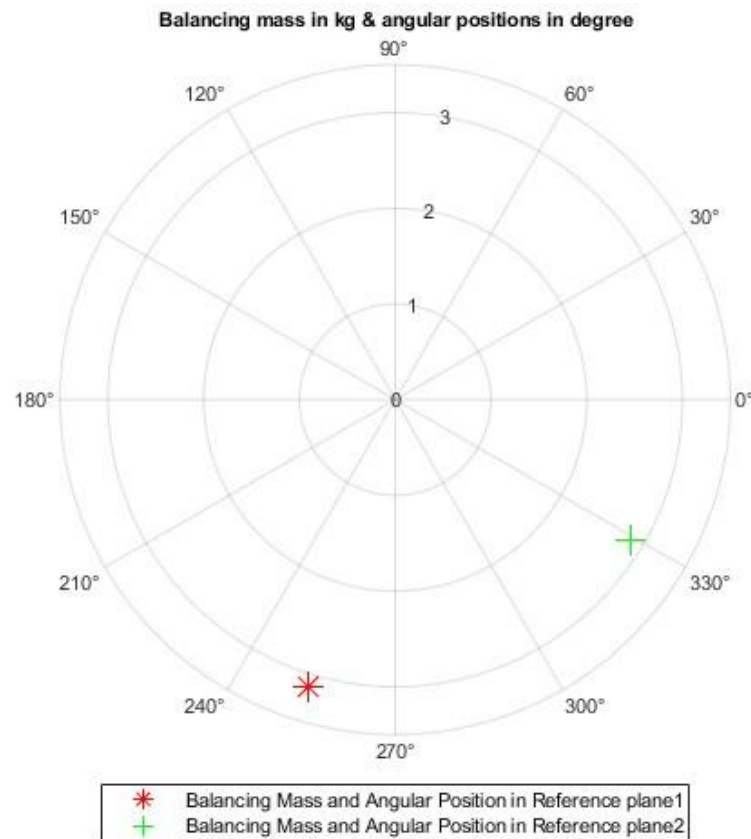

Figure 2. The distribution of balancing mass and their angular position

```

Command Window

>> Verification_Numerical_14_3_TOM_SS_Rattan_03_Feb_2022

Balancing_Mass_and_Angular_Position_in_Reference_plane1 =

    3.1412
    253.2393

Balancing_Mass_and_Angular_Position_in_Reference_plane2 =

    2.8680
    329.2767
    
```

Figure 3. The screen shot of results of MATLAB code

4.3. CAD (NX) modeling

As it was quite clear that there is certain eccentricity in the rail wheel, a CAD model of the rail wheel was operated upon for various subset operations and it was found that arc shaped elemental volumes, in the hub and rim portions, left during the tread turning operation, contributed to the unbalance. Figure-4 presents an elemental arc during the unbalance calculation simulation using the CAD modeling [7]-[9], with trial and error approach. The volume and mass of the arc element were calculated. To approximately match the unbalance, the eccentricity was calculated to be around 325 micros.

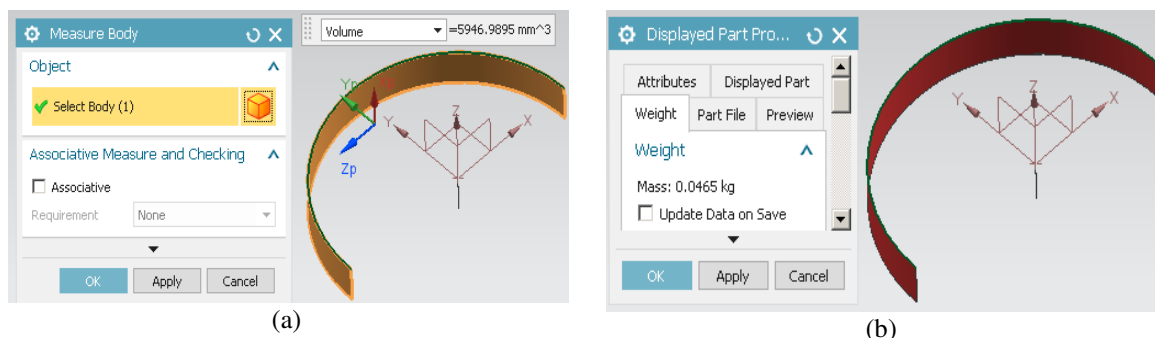

Figure 4. CAD simulation for volume and Mass, (a) Volume calculation, (b) Mass calculation

4.4. Axis Offset

With the confidence achieved from the MATLAB solution of dynamic balancing equations applied to wheel set, CAD modeling and correlation of eccentricity and the un-balancing weights, the assumption that there is eccentricity in the rail wheel boring got strengthened and now it was required to correlate and transform the simulated eccentricity to the wheel boring machine for correlation and eradication of problem.. The pre- anticipated markings were done on the wheel web to match the heavy and light points on the wheel using the trial and error method to achieve a minimum variation which amounted to be about 10 degrees in relation to each wheel. The in-depth scrutiny and inspection was done to find any leftover clues of eccentricity to re-confirm from the physical evidences. In ten wheel sets the measurement for deviation of inner race of wheel was conducted using the dial test indicator and a deviation of 310 microns to 340 microns was observed. This deviation when transformed to the rail wheel position on the chuck of wheel boring machine indicated that the axis of the rail wheel when fixed on the machine chuck was offset.

To confirm the analytical simulation values and observations, the wheel boring machine was checked for the offset, using the semi-finished rail wheel as test piece with dial test indicator and it was observed that an offset of 328 microns existed with that particular rail wheel working as test piece.

4.5. Solution

The wheel boring machine was adjusted for the axis offset and the reduction in the consumption of balancing weight was achieved by 95.9%. The table-1 presents the comparison of balancing weight consumption for production of two different days, one before the implementation of results and one after the implementation of the results and suggestions arising out of this study.

Table 1 - Comparative results

Balancing weight consumed on 24 Jan, 2020 per wheel set in grams	Balancing weight consumed on 24, Mar 2020 per wheel set in grams	Saving of balancing weight per wheel set in grams	% Saving of balancing weight per wheel set in grams
250.13	10.19	239.94	95.9

5. DISCUSSION AND CONCLUSION

The consumption of balancing weights was reduced and it is noted that the wearing out of the rollers contributed to the random variation and the main source of un-balance generation was the wheel boring machine. The correction in the off-set adjustments of the chuck assembly solved the problem. Here one can conclude that the consumption of external balancing weights in the rail wheel sets can be grading criteria for the quality of the wheel set production.

ACKNOWLEDGEMENTS

The author is grateful to the Chief Design Engineer for providing the necessary permission to conduct the study. Author is thankful to MathWorks® in supporting the programming work and solution by providing access to MATLAB® software. Author is also grateful to the wheel shop in-charge and all the staff for providing accommodative environment for the successful completion of this study.

CONFLICTS OF INTEREST

The author(s) declared no potential conflicts of interest with respect to the research, authorship, and/or publication of this article.

REFERENCES

- [1] B. Pintao, A. Mosleh, C. Vale, P. Montenegro and P. Costa, "Development and Validation of a Weigh-in-Motion Methodology for Railway Tracks," *Sensors*, vol. 22, pp. 19769(1-20), 2022.
- [2] B. Hunt, R. Lipsman, J. Rosenberg, K. Coombes, J. Osborn and G. Stuck, "A guide to MATLAB for Beginners and Experienced Users", Cambridge University Press, New York, 2001.
- [3] S. R. Otto and J. P. Denier, "An Introduction to Programming and Numerical Methods in MATLAB", Springer, USA, 2005.
- [4] S. J. Chapman, "MATLAB: Programming for Engineers", Fourth Edition, Thomson, Canada, 2008.
- [5] MATLAB The Language of Technical Computing, *MATLAB Programming* MathWorks Inc, 2005.
- [6] S. S. Ratan, "Theory of machines", Tata McGraw Hill, New Delhi, 2009.
- [7] Y. O. Elgammal and A. A. Gaffar, "Computer Aided Drafting Application (CAD) as – A Design Tool," *International Journal of Architecture, Arts and Applications*, vol. 7(4), pp. 107-118, 2021.
- [8] M. Saini, "AI and its Application in CAD," *International Journal of Advances in Engineering and Management*, vol. 5(4), pp. 1874-0879, 2023.
- [9] B. R. Hunde and A. D. Woldeyohannes, "Future Prospects of Computer-Aided Design (CAD) – A Review from the Perspective of Artificial Intelligence (AI), Extended Reality, and 3D Printing," *Results in Engineering*, vol.14, pp. 1-9, 2022.