

Development of Power Management on Unmanned Surface Vehicles to Measure Battery Voltage and Power

Diana Alia*, Henna Nurdiansari, Akhmad Kasan Gupron, Amelia Greacy Talenta Siregar

Marine Electricity Engineering, Politeknik Pelayaran Surabaya, Indonesia
**Corresponding author: diana.alia@polteknik-pel-sby.ac.id*

Article history:

Received: 27 September 2024 / Received in revised form: 3 November 2024 / Accepted: 11 November 2024
Available online 31 January 2025

ABSTRACT

This research focuses on designing an electrical system for unmanned surface vehicles (USV) to ensure optimal performance during survey operations. This USV ship is a catamaran-type ship with a Sonar Deeper depth sensor to know the depth of the water and is equipped with long range (LoRa) as a data transmitter. The USV electrical system design incorporates the use of a 4050 mAh 11.1 V LiPo battery and an iMAX B6AC charger, with evaluations covering battery charging, power consumption, and voltage stability. The trials showed that the battery supported the operation of the USV for approximately 47.8 minutes at a power load of 45.08 Watts. Battery charging showed two main phases: constant current and constant voltage, with a full charge time of approximately 2.7 hours. During operation, voltage consumption showed significant fluctuations, highlighting the need for an electrical system design that maintains voltage stability to improve performance. From the test results, the battery efficiency was found to be 91.29%. These findings emphasize the importance of appropriate component selection and efficient power management to achieve reliable and efficient USV operation. With a deep understanding of the charging characteristics and power consumption, the designed electrical system can ensure more stable USV operation and better performance under various survey conditions.

Copyright © 2025. Journal of Mechanical Engineering Science and Technology.

Keywords: *Electrical system, LiPo battery, power consumption, unmanned surface vehicle, voltage stability*

I. Introduction

Unmanned Surface Vehicle (USV) is one of the advances in maritime technology that is now beginning to be applied in Indonesia's waters, especially for surveying [1]. By combining autonomous navigation, environmental sensors, and multibeam echo sounders, the USV is able to collect important data such as topography and temperature, which are invaluable to the shipping world [2], [3]. Its main advantage is the ability to conduct surveys in dangerous or hard-to-reach areas without putting humans at risk while maintaining smooth shipping traffic [4].

Unmanned Surface Vehicles (USVs) are emerging as a valuable tool for maritime operations in Indonesia and globally. This autonomous boat integrates a navigation system, environmental sensors, and a multibeam echosounder to collect important data such as bathymetry and temperature [5]. USVs offer advantages in surveying dangerous or inaccessible areas without risking human lives, while maintaining the smooth flow of maritime traffic [6]. Recent developments include an affordable design with a rudderless configuration and two thrusters as well as proportional integral derivative (PID) control for autonomous missions [7]. Performance tests in Indonesia waters have shown good stability and data collection capabilities, with roll and pitch values within an acceptable range [6].



The technology has evolved from a research concept to a commercial product, with applications in various maritime sectors. However, challenges still exist in fully meeting the specific needs of the maritime industry [8].

However, despite the promise of this technology, its application in Indonesia still faces significant challenges, especially in terms of electrical system design. This challenge is not something that can be ignored. The electrical system on a USV is very important because it is the backbone of all its operations, from the propulsion system to sensors and communications. Failures in the electrical system can cause the USV to be unable to maneuver, lose orientation, lose communication, and all sensors to fail. Poor power management can cause power outages during a mission, limiting the USV's operational duration. The electrical load on a large USV requires very careful energy planning [9]. Inaccuracies in the selection of generators or batteries are not just a technical matter but can lead to serious problems that affect the performance and stability of the ship. A USV that loses stability not only fails to carry out its mission but can also be a threat at sea [10].

Recent research has explored the design of electrical systems for USVs and marine vessels. Zaldi and Zainal developed a USV prototype control system using an Arduino microcontroller and remote control, with a maximum communication range of 80 meters [11]. For electric vehicles, an electrical system with four 12V batteries arranged in series, providing a maximum power of 152,424 watts was designed by Mulyadi et al. [12]. Mahmuddin et al. [13] emphasized the importance of an emergency power system on ferries, recommending generator capacity planning and careful cable diagram design. Dewantara [14] proposed a solar-powered electrical system for fishing vessels, utilizing photovoltaic modules to power various equipment on board. Their design includes four 210 Wp solar panels, a 60 A charge controller, and twenty 100 AH batteries. These studies demonstrate diverse approaches in electrical system design for different maritime applications, with a focus on efficiency, reliability, and sustainability [15].

The papers highlight the crucial role of electrical systems in maritime vessels, emphasizing safety and efficiency. Proper planning for emergency power systems is essential for ferry operations [13]. Hybrid power systems that combine solar panels and diesel generators offer the potential to reduce fuel consumption and emissions on ships [16]. The selection of generator capacity is crucial, with studies showing that a 13 kVA generator can meet 77% of the maximum load requirements for a 15 GT fishing vessel [17]. Electrical safety systems are vital, especially for large commercial vessels that use diesel generators as the primary power source. Proper maintenance and repair of diesel generators are necessary for optimal ship performance [18]. These studies emphasize the importance of careful electrical system design, generator selection, and safety measures in maritime applications to ensure ship stability and operational efficiency. This is where some crucial questions arise: How to design the right electrical system for USVs? How to ensure that this system not only supports but also improves the performance of the USV during operation? It needs a technical solution and also explores optimal energy requirements and battery life under maximum usage conditions. Thus, the resulting electrical system design is expected to meet the operational needs of the USV well, ensuring stability, efficiency, and the success of each survey mission carried out [19]. So, this study aims to design an electrical system for USV to ensure optimal performance during survey operations.

II. Material and Methods

The design of this research system is designed in stages and systematically to ensure that each stage of the design of the USV electrical system meets the technical specifications and functions optimally in the field [20]. Figure 1 shows a step-by-step electricity design where power, voltage, and current are factors that are taken into consideration apart from dimensions and weight. The battery type is chosen by taking into account the ship's dimensions, maximum load, and the power required by the USV ship, as well as a low cost. The 4050 mAh LiPo battery was chosen as the main power source, supported by a battery indicator system that provides real-time information about the power status, which is important for the continuity of the USV operation [5], [21].

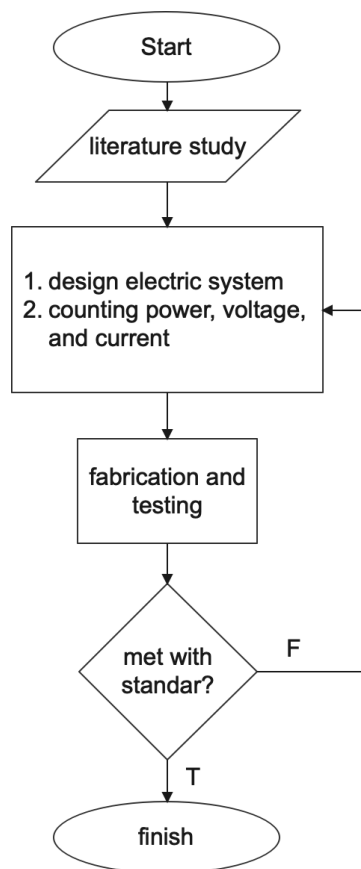

Fig. 1. Flow chart of electricity design

1. Construction Design

The USV uses a catamaran design with a double hull, 1 meter long, 0.4 meter wide, and 0.2 meter high, driven by a 1620 kV DC brushless motor. The design of the laying of the electrical system is arranged to maintain the stability and efficiency of the ship [22]. In this proposed method, the USV dimension is shown in Table 1.

For the design of the laying of the electrical system for the surface vehicle, this catamaran will be made in such a way that it is in accordance with the ship's proportions that pay attention to stability and efficiency. The laying design for the electrical system will be designed on the hull arranged in such a way as to keep in mind the stability of the ship which can be seen in Figure 2.

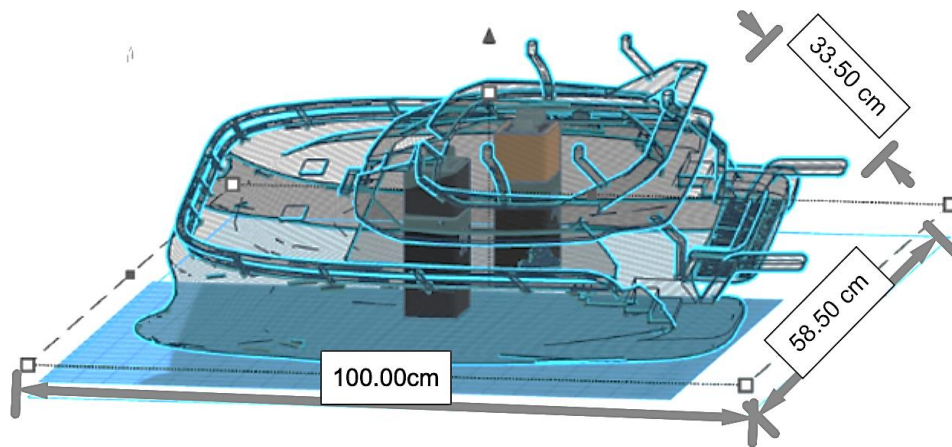

Fig. 2. Construction of catamaran ships

Table 1. Ship Particular

Submerged Length	0.85 meter
Submerged Breadth	0.16 meter
Submerged Draft	0.07 meter
Lpp	0.67 meter
LOA	0.96 meter
LWL	0.85 meter
Draught of Beam	0.4 meter
Beam Depth	0.2 meter

2. Electrical Load Calculation and Battery

The load consists of a drive motor, a DC pump, an electronic speed controller (ESC), a servo motor, and a microcontroller. Testing of the 4050 mAh LiPo battery shows that it meets the power needs of the USV and the calculation of battery life used Eq. (1). Table 2 shows the details of the voltage and current for each load.

Table 2. List of load voltages and currents

Component	Power Max (Watt)	Voltage Max (V)	Current Max (Ampere)
Motor driver	24.00	12.00	2.00
Arduino Uno	0.25	5.00	0.05
DC pump	1.50	6.00	0.25
ESC encoder	0.53	6.00	0.09
Motor servo	6.00	6.00	1.00
Long range	0.07	3.30	0.02
Receiver	0.03	3.00	0.01
Compas	0.15	5.00	0.03
Rotary encoder	0.12	4.00	0.03

$$Battery\ life = \frac{Battery\ Capacity\ (Wh)}{Power\ consumption\ (W)} \dots\dots\dots(1)$$

The main source of electricity on this USV is a Lipo battery; the battery is directly connected to electrical loads such as cooling pumps, ESCs, and DC motors [17]. For other loads, the voltage from the battery must pass through a voltage divider circuit, to meet the small voltage required by microcontrollers such as Arduino Uno, rotary encoders, remote receivers, compasses, and LCD monitors.

3. Battery Indicator Series

Battery indicators in the form of red, yellow, and green lights are used to indicate the power status, which is added to prevent running out of power in the middle of operation. The power indicator on the battery used in this USV is an indicator in the form of a lamp [23]. The indicator lights are red, yellow, and green. Red indicates that the battery is low (<25%), yellow indicates a medium battery (25% < battery > 75%), while green indicates that the battery still has enough power in the range of >75% [24]. In this proposed method, the indicator battery, as shown in Figure 4, is placed inside the USV and also on the remote control. Where the battery indicator data is sent to the remote control so that it can be displayed on the LCD.

Figure 3 shows the voltage divider circuit to be used on the battery level indicator. This series is added to indicate the battery level, as shown in Figure 4, to the operator in order to avoid this USV running out of power in the middle of the water.

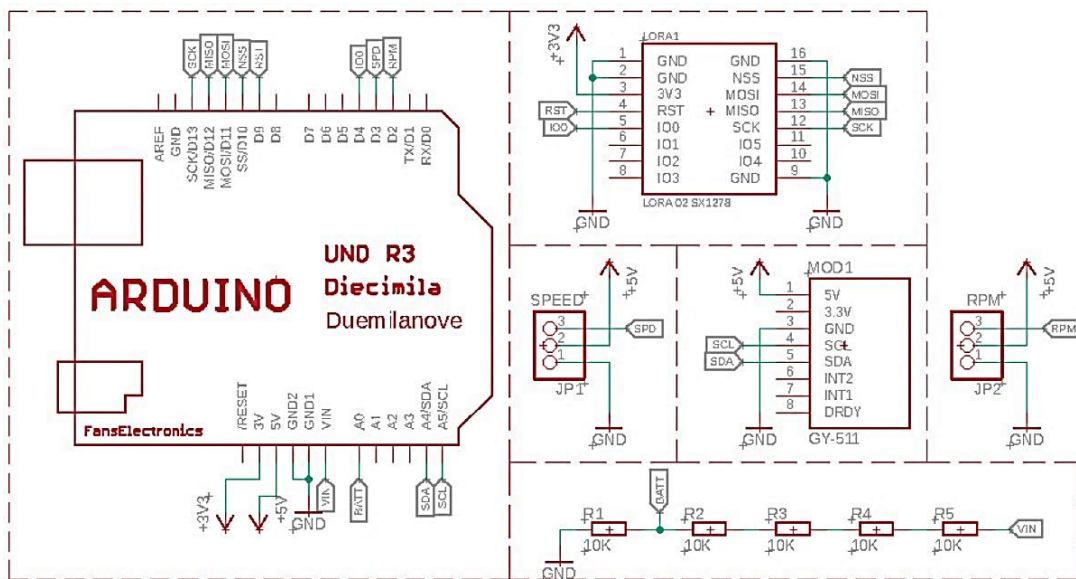

Fig. 3. Wiring diagram of electricity design

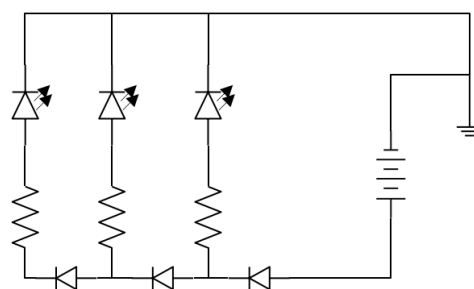

Fig. 4. Battery indicator level circuit

4. Product Trial Design

USV testing is focused on electrical system reliability, battery life, charging time, and voltage and rotation per minute (RPM) input analysis to ensure operational stability and efficiency. Charging efficiency, expressed in Eq. (2), indicates how efficiently the charging process converts electrical energy into stored energy in the battery, accounting for energy losses such as heat. Initial testing is carried out in swimming pools to identify and fix problems before intensive testing in the field [25],[26].

$$\text{Charging Efficiency} = \frac{\text{Energy Used to Charge the Battery}}{\text{Energy Stored in the Battery}} \times 100\% \dots \dots \dots (2)$$

III. Results and Discussions

Product test results testing of USV products is essential to ensure the design meets operational needs, especially with regard to electrical power consumption [27]. The test aims to analyze energy requirements and ensure optimal performance. Errors in testing can result in inefficient and unreliable products [28]. Testing of catamaran ship components, the stability of ships, and other components is a crucial step to ensure that the ship's design can withstand the expected loads, as shown in Figure 5. Draft checks, weight distribution, and buoyancy are important indicators for the stability and performance of the vessel [29].



Fig. 5. Catamaran hull trials

Battery and motor testing LiPo batteries with a capacity of 4050 mAh and a voltage of 12V are tested to support USV operation. Although simple, testing with an AVO meter provides basic information about the battery voltage. It does not reflect performance under actual load. Servo motors and DC pumps are tested to ensure functionality under a wide range of operating conditions, including resistance to voltage drops [30]. The actual testing is taken when the USV is operating in the waters. all active components are by their functions. USV runs in water and revolves around the pool until the battery level is less than 25%.

The DC pump test was carried out by being given a voltage of 12 V. Once stressed, the DC pump can suck and circulate the cooling water. However, although the DC pump is functioning well at the initial voltage, critical observation of its performance is necessary when the battery experiences a drop of up to 3.3 volts. At this voltage level, even if the pump is still operating, the performance and efficiency of the pump may be affected. It is important to evaluate whether this voltage drop is significantly affecting the suction and circulation power of the pump, as well as to ensure that the cooling system remains effective in critical conditions. Further analysis is needed to ensure that the DC pump is not only functioning under ideal conditions but can also operate reliably over longer periods and at low voltage conditions.

This brushless DC motor is supplied with a voltage of 11.1 V, 4050 mAh, so the voltage provided also affects the resulting RPM. With full battery voltage, the motor can produce 11332 RPM [31]. The part tests as shown in Figures 6 and 8 were carried out using a stroboscope to measure motor RPM and an AVO meter to measure voltage and amperage. From the test results, data on the maximum RPM and current consumption were obtained using motors with different battery voltages [32]. Figure 7 shows the correlation between motor speed and current (shown by the red line), and the correlation between motor speed and voltage (shown by the blue line), where motor speed is directly proportional to current and voltage. According to Figure 7, in this proposed method, to generate 2000 RPM, a voltage of 6.5 V and a current of 2 A is required.



Fig. 6. DC pump testing

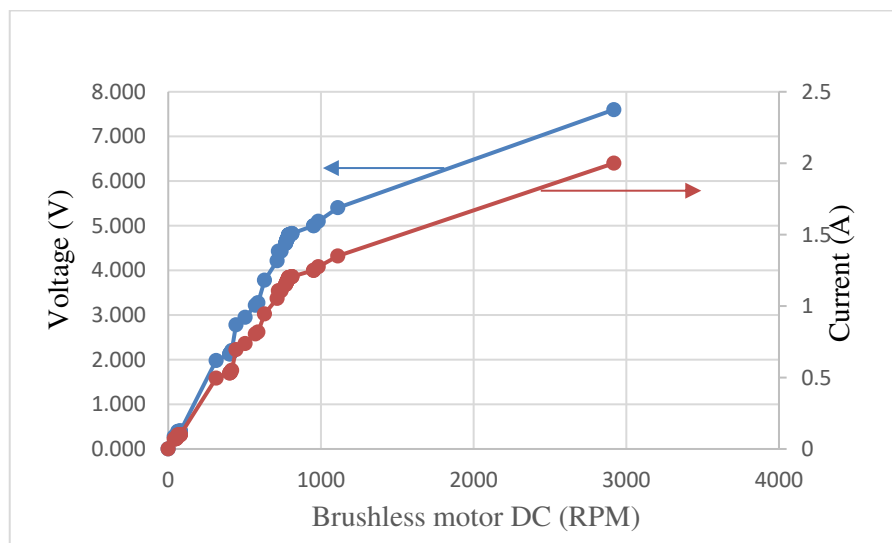

Fig. 7. Brushless DC motor test results

Figure 8 shows the test results of brushless DC motors with different voltage and current variations. From this data, it can be seen that the relationship between voltage, current, and RPM is always linear, which requires more in-depth analysis. At a voltage of 7.6 V, the motor produces a maximum RPM of 2919 with a current of 2.0 A, while at a higher voltage of 11.1 V, the current increases to 2.8 A, and the maximum RPM jumps sharply to 11332. These results prove that RPM is directly proportional to voltage and electric current.



Fig. 8. DC brushless motor testing

Figure 9 shows the average time taken to recharge the battery. It takes about 2 hours and 40 minutes to charge the battery. This measurement will later be used to calculate the battery efficiency. The Arduino was tested by comparing the accuracy of the voltage measured on the battery using an Avometer and the voltage recorded on the monitoring LCD, as shown in Figure 10.

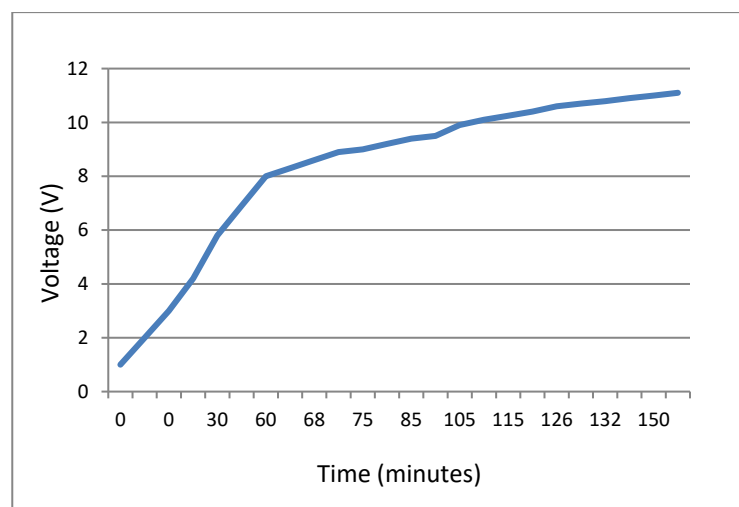

Fig. 9. Charging duration



Fig. 10. Data accuracy testing between Arduino and AV meter

The electrical schematic design of the USV is a graphical representation of the electrical system in the Uninterruptible Power Supply unit. The schematic design of the USV BLDC motor can be seen in Figure 11. This schematic describes the relationship between the electrical components contained in the USV, including the input power source, the electrical functions that occur in the USV, and how the output power source is arranged. The main source of electricity in this USV is the Lipo battery, from the battery directly connected to the electrical load such as the cooling pump, ESC, and DC motor. For other loads, the voltage from the battery must pass through a series of voltage dividers, to meet the small voltage required by microcontrollers such as Arduino Uno, rotary encoder, remote receiver, compass, and LCD monitor [31]. In ballast systems, flow meters help measure the volume of water taken in or taken out of the ballast tank to adjust the balance and trim of the vessel. Ballast regulation is critical for USV stability and maneuverability, especially on unmanned ships that rely on automated systems. According to Table 2, the total load of USV is 32.65W. By using Eq (1), and Eq. (2), the battery life can be calculated as 1.37 hours or 1 hour 22 minutes, and charging efficiency of 91.29%.

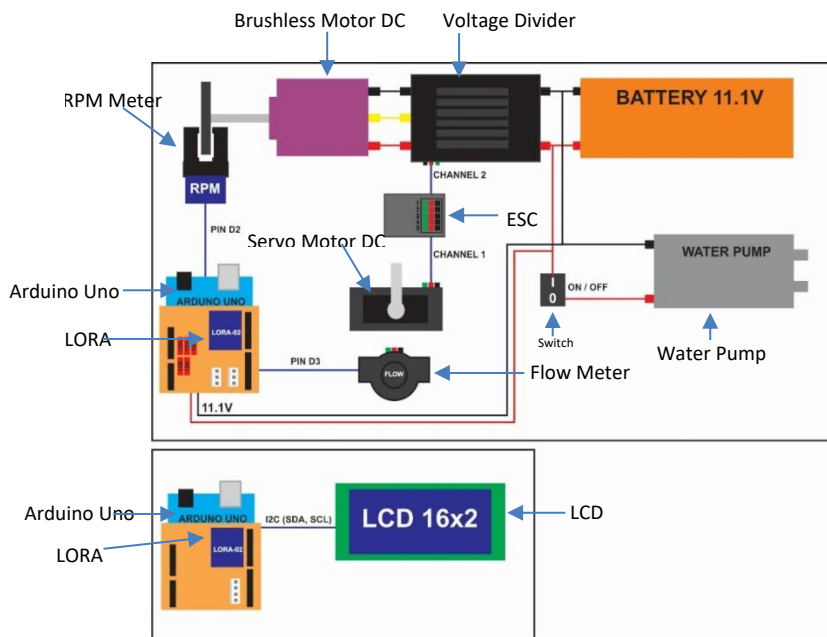

Fig. 11. Electrical schematic design of USV

The battery capacity used is actually sufficient, but it is very close to the power limit needed. With an efficiency of 91.29%, this battery is classified as high-performance,

corresponding to Lithium-ion having an efficiency between 85% and 95%. This energy is usually lost as heat due to internal resistance or other factors such as incomplete chemical reactions. This means that it may be necessary to consider batteries with a larger capacity to ensure stable USV operation, especially when under full load [32]. This is important, not only to meet basic needs but also to provide sufficient power reserves to deal with unexpected situations. Secondly, when tested, the battery charging system turned out to be very important for long-term operation [33]. If charging the battery takes too long, this can hinder missions that require quick readiness. So, efficient and safe charging management must be considered. The use of the iMAX B6AC charger is good, but it is necessary to make sure that the charging process is fast and does not reduce battery life [34].

Voltage stability during operation is critical to the overall performance of the USV. There are voltage fluctuations when the motor is operating at high RPM, which indicates the need for components that can keep the voltage stable, such as voltage regulators and responsive ESCs [35]. If the voltage is unstable, the motor and other components can be disrupted, which can lead to failures in operation. Overall, the electrical system must more than meet basic needs. The system needs to be designed to anticipate and address the challenges that arise during USV operations [36]. By selecting the right battery, ensuring charging efficiency, and maintaining voltage stability, the performance and reliability of the USV can be significantly improved under a wide range of conditions [37].

IV. Conclusions

Based on the data and analysis that has been carried out, the design of the electrical system for the unmanned surface vehicle (USV) needs to pay attention to several important aspects to achieve optimal performance. Tests show that a LiPo battery with a capacity of 4050 mAh and a voltage of 11.1 V is sufficient to support USV operation during an adequate time. However, it is important to choose a battery with a slightly larger capacity to avoid degraded performance, given that the power load is close to the capacity of the battery. The battery charging system, which uses a professional charger such as the iMAX B6AC, takes about 2.7 hours to charge the battery to full capacity. This confirms the need for an efficient charging system in the design to ensure power is available quickly and safely. Additionally, voltage fluctuations detected during testing demonstrate the importance of maintaining voltage stability. The use of components such as motor speed controllers (ESCs) and effective voltage regulators is indispensable to maintain system stability and maximize USV performance in the field. Overall, the proper design of an electrical system involves the selection of appropriate components, efficient power and charging management, and stable voltage control. With this approach, the electrical system not only supports but also improves the performance of the USV, ensuring reliable and efficient operations.

Acknowledgment

In this study, we would like to express our deepest gratitude to all parties who have provided very meaningful support and contributions. We would also like to express our special thanks to the laboratory team who have assisted in the testing and analysis of the data, as well as to our colleagues who have provided moral and technical support. This research is also inseparable from the contribution and dedication of all parties involved in the development and testing of electrical systems, including component and device providers who play an important role in this study. Hopefully, the results of this research can provide significant benefits in the development of electrical systems for USVs and improve reliability and operational efficiency in the future.

References

- [1] D. Zhao, T. Yang, W. Ou, and H. Zhou, "Autopilot design for unmanned surface vehicle based on CNN and ACO," *International Journal of Computers, Communications and Control*, vol. 13, no. 3, pp. 429–439, 2018, doi: 10.15837/ijccc.2018.3.3236.
- [2] J. Xin, J. Zhong, F. Yang, Y. Cui, and J. Sheng, "An improved genetic algorithm for path-planning of unmanned surface vehicle," *Sensors (Switzerland)*, vol. 19, no. 11, pp. 1–23, 2019, doi: 10.3390/s19112640.
- [3] A. Yang, W. Naeem, G.W. Irwin, and K. Li, "Stability analysis and implementation of a decentralized formation control strategy for unmanned vehicles," *IEEE Transactions on Control Systems Technology*, vol. 22, no. 2, pp. 706–720, 2014, doi: 10.1109/TCST.2013.2259168.
- [4] E.I. Sarda, H. Qu, I.R. Bertaska, and K.D. von Ellenrieder, "Station-keeping control of an unmanned surface vehicle exposed to current and wind disturbances," *Ocean Engineering*, vol. 127, pp. 305–324, 2016, doi: 10.1016/j.oceaneng.2016.09.037.
- [5] F. Sotelo-Torres, L.V. Alvarez, and R.C. Roberts, "An unmanned surface vehicle (USV): development of an autonomous boat with a sensor integration system for bathymetric surveys," *Sensors*, vol. 23, no. 9, 2023, doi: 10.3390/s23094420.
- [6] R. Fauzi, I. Jaya, and M. Iqbal, "Unmanned surface vehicle (USV) performance test in Bintan Island Waters," *IOP Conference Series: Earth and Environmental Science*, vol. 944, no. 1, 2021, doi: 10.1088/1755-1315/944/1/012013.
- [7] J.D. Setiawan, M.A. Septiawan, M. Ariyanto, W. Caesarendra, M. Munadi, S. Alimi, "Development and performance measurement of an affordable unmanned surface vehicle (USV)," *Automation*, vol. 3, no. 1, pp. 27–46, 2022, doi: 10.3390/automation3010002.
- [8] C. Barrera, I. Padron, F.S. Luis, O. Llinas, and G.N. Marichal, "Trends and challenges in unmanned surface vehicles (Usv): From survey to shipping," *TransNav*, vol. 15, no. 1, pp. 135–142, 2021, doi: 10.12716/1001.15.01.13.
- [9] Z. Liu, Y. Zhang, X. Yu, and C. Yuan, "Unmanned surface vehicles: An overview of developments and challenges," *Annual Reviews in Control*, vol. 41, no. March 2018, pp. 71–93, 2016, doi: 10.1016/j.arcontrol.2016.04.018.
- [10] H. Halvorsen, *Cybernetics Dynamic Positioning for Unmanned Surface Vehicles*, Master of Thesis, Norwegian University of Science and Technology, pp. 1–104, June 2008.
- [11] A.Y.Z. Zaldi, and M. Zainal, "Perancangan sistem kendali dan navigasi pada prototype unmanned surface vehicle (USV)," *Jurnal Mosfet*, vol. 3, no. 1, pp. 10–17, 2023, doi: 10.31850/jmosfet.v3i1.2313.
- [12] R. Mulyadi, K.D. Artika, and M. Khalil, "Perancangan sistem kelistrikan perangkat elektronik pada mobil listrik," *Elemen : Jurnal Teknik Mesin*, vol. 6, no. 1, p. 07, 2019, doi: 10.34128/je.v6i1.85.
- [13] F. Mahmuddin, B. Baharuddin, and M. Natsir, "Kebutuhan listrik untuk keadaan darurat pada kapal Ferry Ro-Ro KMP. Tuna 600 GRT," *Jurnal Penelitian Enjiniring*, vol. 23, no. 1, pp. 45–51, 2019, doi: 10.25042/jpe.052019.07.
- [14] B. Y. Dewantara, "Perancangan perahu nelayan ramah lingkungan menggunakan motor listrik bertenaga surya," *Cyclotron*, vol. 2, no. 1, pp. 1–4, 2019, doi: 10.30651/cl.v2i1.2530.
- [15] A. Makhsoos, H. Mousazadeh, and S.S. Mohtasebi, "Evaluation of some effective parameters on the energy efficiency of on-board photovoltaic array on an unmanned

- surface vehicle,” *Ships and Offshore Structures*, vol. 14, no. 5, pp. 492–500, 2019, doi: 10.1080/17445302.2018.1509413.
- [16] P.G. Chamdareno, E. Nuryanto, and E. Dermawan, “Perencanaan sistem pembangkit listrik hybrid (panel surya dan diesel generator) pada kapal KM. Kelud,” *RESISTOR (elektRONika kEndali telekomunikaSI tenaga liSTrik kOmputeR)*, vol. 2, no. 1, p. 59, 2019, doi: 10.24853/resistor.2.1.59-64.
- [17] I.K.B.S. Darma, U. Mudjiono, A.S. Setiyoko, and J. E. Poetro, “Analisis kapasitas generator pada kapal ikan 15 Gt,” *Jurnal 7 Samudra*, vol. 7, no. 1, 2022, doi: 10.54992/7samudra.v7i1.102.
- [18] M. Marwiyah Nst, Y. Sutria, and T. Taruna, “Sistem pengaman kelistrikan kapal di Belawan,” *Journal of Maritime and Education (JME)*, vol. 5, no. 1, pp. 456–461, 2023, doi: 10.54196/jme.v5i1.100.
- [19] H. Nurhadi, E. Apriliani, T. Herlambang, and D. Adzkiya, “Sliding mode control design for autonomous surface vehicle motion under the influence of environmental factor,” *International Journal of Electrical and Computer Engineering*, vol. 10, no. 5, pp. 4789–4797, 2020, doi: 10.11591/ijece.v10i5.pp4789-4797.
- [20] I. Bae and J. Hong, “Survey on the developments of unmanned marine vehicles: Intelligence and cooperation,” *Sensors*, vol. 23, no. 10, 2023, doi: 10.3390/s23104643.
- [21] Synopsys, “What is a Battery Management System?,” Synopsys, 2024, [Online]. Available: <https://www.synopsys.com/glossary/what-is-a-battery-management-system.html>.
- [22] V. Bolbot, A. Sandru, T. Saarniniemi, O. Puolakka, P. Kujala, and O.A. V. Banda, “Small unmanned surface vessels—A review and critical analysis of relations to safety and safety assurance of largerautonomous ships,” *Journal of Marine Science and Engineering*, vol. 11, no 12, pp. 2–28, 2023, doi: 10.3390/jmse11122387
- [23] M. Puzan, “Rancangan alat indikator level tegangan baterai berbasis operational amplifier (Op Amp),” *Teknokom*, vol. 2, no. 1, pp. 11–16, 2019, doi: 10.31943/teknokom.v2i1.26.
- [24] M. Kilinc, “Modeling and control of a fully actuated unmanned,” Master of Thesis, The Graduate School of Natural and Applied Science, Middle East Technical University, Ankara, Turkey, April, 2023.
- [25] G. Romeo, G. Frulla, and E. Cestino, “Design of a high-altitude long-endurance solar-powered unmanned air vehicle for multi-payload and operations,” *Proceedings of the Institution of Mechanical Engineers, Part G: Journal of Aerospace Engineering*, vol. 221, no. 2, pp. 199–216, 2007, doi: 10.1243/09544100JAERO119.
- [26] M. Breivik, V.E. Hovstein, and T.I. Fossen, “Straight-line target tracking for unmanned surface vehicles,” *Modeling, Identification and Control*, vol. 29, no. 4, pp. 131–149, 2008, doi: 10.4173/mic.2008.4.2.
- [27] S.W. Satoto, N.A. Prasetyo, and A.L.A. Risdianto, “A 3 Ft gurindam unmanned surface vehicle (USV) stability hullform performance,” *Jurnal Teknologi dan Riset Terapan (JATRA)*, vol. 2, no. 2, pp. 2685–4910, 2020.
- [28] K. Watanabe and M. Shimpo, “Development of a USV testbed and its system check experiments at sea,” *Proceedings of International Conference on Artificial Life and Robotics*, no. 1, pp. 789–792, 2022, doi: 10.5954/icarob.2022.os29-6.
- [29] U. Son, J.S. Yoon, J.H. Huh, and J.H. Choo, “Empirical study on the development of ESS-based electric propulsion system for a catamaran USV,” *IEEE Access*, vol. 11, no. June, pp. 66895–66909, 2023, doi: 10.1109/ACCESS.2023.3289938.

- [30] K. Alam, *Development of an Optimization Framework for the Design of Unmanned Underwater Vehicles,*” Dissertation, School of Engineering and Information Technology, University of New South Wales, Canberra, Australia, 2024.
- [31] M.A. Salam, R.E.A. Kadir, and N. Gamayanti, “Modeling and control unmanned surface vehicle (USV) with hybrid drivetrain,” *JAREE (Journal on Advanced Research in Electrical Engineering)*, vol. 3, no. 2, pp. 72–77, 2019, doi: 10.12962/j25796216.v3.i2.86.
- [32] P. Sattayasoonthorn and J. Suthakorn, “Battery management for rescue robot operation,” *2016 IEEE International Conference on Robotics and Biomimetics, ROBIO 2016*, pp. 1227–1232, 2016, doi: 10.1109/ROBIO.2016.7866493.
- [33] D. H. L. Technology, “(2) Why Is Your Service Battery Charging System Lit Up and What Can Hoppt Battery Do to Help? | Link,” Dongguan Hoppt Light Technology. <https://www.linkedin.com/pulse/why-your-service-battery-charging-system-lit-up-what-can-hoppt-howhc/>.
- [34] A.M. Bradley, M.D. Feezor, H. Singh, and F.Y. Sorrell, “Power systems for autonomous underwater vehicles,” *IEEE Journal of Oceanic Engineering*, vol. 26, no. 4, pp. 526–538, 2001, doi: 10.1109/48.972089.
- [35] I. Hamidah, D.F. Ramadhan, R. Ramdhani, B. Mulyanti, R.E. Pawinanto, L. Hasanah, A.B.D. Nandiyanto et al., “Overcoming voltage fluctuation in electric vehicles by considering Al electrolytic capacitor-based voltage stabilizer,” *Energy Reports*, vol. 10, pp. 558–564, 2023, doi: 10.1016/j.egy.2023.07.009.
- [36] J. Strickland, D. Carlucci, C. Serratella, M. Dowling, and R. Delpizzo, “Development of an equipment and system reliability qualification process for unmanned surface vessels,” *SNAME Maritime Convention 2021, SMC 2021*, no. October, 2021, doi: 10.5957/SMC-2021-042.
- [37] Y.L. Wang, Q.L. Han, M.R. Fei, and C. Peng, “Network-based T-S Fuzzy dynamic positioning controller design for unmanned marine vehicles,” *IEEE Transactions on Cybernetics*, vol. 48, no. 9, pp. 2750–2763, 2018, doi: 10.1109/TCYB.2018.2829730.