

# Vehicle Safety System Integrated with GSM Network (*Global System for Mobile Communications*) on Vehicle Ignition System

Akhmad Riszal<sup>1</sup>, Suryadiwansa Harun<sup>1</sup>, Yanuar Burhanuddin<sup>1</sup>, Martinus<sup>1</sup>, Arinal Hamni<sup>1</sup>, Rizal Adi Saputra<sup>1</sup>, and Rizal Nazarrudin<sup>1,\*</sup>

<sup>1</sup> Department of Mechanical Engineering, Faculty of Engineering, University of Lampung, Building H, Floor. 2, Jl. Prof. Soemnantri Brojonegoro No. 1, Bandar Lampung 35143, Indonesia

\*Corresponding Author: [rizalnazar@eng.unila.ac.id](mailto:rizalnazar@eng.unila.ac.id)

## Article history

Received: 07.03.2025

Revised: 22.04.2025

Accepted: 28.04.2025

DOI:10.31629/jit.v6i1.7347

## Abstract

This research aims to design and create a sms-based motor vehicle security system with an ATmega 8535 *microcontroller*. This research utilizes *hand phone* technology and *microcontroller*. Making this tool has an economical price to secure motorized vehicles. Important *prototypes* in making this tool are the ATmega 8535 *microcontroller*, GSM Modem and HP. In making this tool the first thing to make is to make a *microcontroller* program for the controller. Making this program uses CV Avr *soft ware* (*Code Vision Avr*). After the program is finished, the program is *downloaded* to the *microcontroller*. Control is done by the *microcontroller* when it gets *input*. The result of this research is to get a vehicle security system that is integrated by the ignition system on a motorcycle. The process of securing a motorized vehicle when it is stolen is, the security system will send sms information that the motorcycle is stolen, the alarm sounds and the ignition system is cut off. To turn off the alarm and start the motorcycle, the owner sends an SMS with the format \*ALOF# to the security system and starts the motorcycle normally (Pull the front brake three times then position the key to ON mode).

**Keywords:** Microcontroller; ATmega 8535; CV Avr; GSM modem; Alarm

## 1. Introduction

Nowadays, motor vehicle theft is increasingly rampant, so there are many sophisticated safety devices to secure vehicles. The more rampant the crime of motor vehicle theft, vehicle owners are required to be more careful and have an extra security system in addition to the main key when the vehicle is parked or left by the owner. The number of vehicles used by the community, there are also many people who have bad intentions and take advantage of the security situation on the vehicle, one of which is motorcycle theft. Motorcycle theft is utilized by the

perpetrator when the vehicle owner is off guard with his motorcycle or away from parking. The mode of motorcycle theft is very diverse. The theft mode is carried out in groups or using sophisticated tools. So that vehicle owners are encouraged to provide additional keys besides the main key to avoid theft. As reported by the Bandar Lampung Police, in 2023 there were 4,476 cases of crime in the city of Bandar Lampung. From the case data, the crime of vehicle theft was theft of motorcycles, which amounted to 468 cases [1]. The data shows that motorcycle theft cases are very large, this is due to the lack of attention and security from

vehicle owners so that theft cases can be easily carried out by thieves.

### 1.1 Safety System

Utilization of cell phones and *microcontrollers* can find out if the vehicle is stolen by using sms facilities to send and receive short text messages via wireless devices and control systems with *microcontrollers*. The text message will be processed by the ATmega 8535 *microcontroller* for remote control notification with modem media (*Modulator-Demodulator*) to exchange vehicle safety system information with the vehicle owner or vice versa. Microcontrollers are small computers in the form of IC chips that function to control various electronic devices automatically, such as in machine control systems, medical equipment, and other embedded devices [2]. *Microcontroller* is used as a center for regulating and controlling the robot or often referred to as the robot's brain. ATmega 8535 can operate at a maximum speed of 16 MHz and has 6 *sleep mode* options to save electrical power usage. The ATmega 8535 pin configuration is the basic function of the *microcontroller* pin configuration that is already in it. As shown in Figure 1:

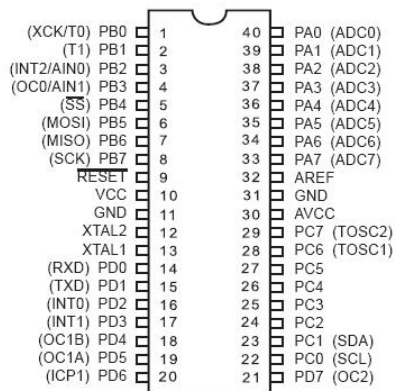

Figure 1. ATmega 8535 Pin Configuration

Previous research on vehicle safety systems using Bluetooth connection via motorcycle rider's hand phone as input [3]. Utilization of Arduino Uno and GSM connection in the form of sms is able to connect according to user commands in turning on and off a lamp [4]. So that the working principle of sms is *store and forward*. This short message delivery between terminals can occur because of the SMSC (Short Message Service Center). The task of this SMSC device is to store and forward

messages from the sender side to the recipient side if the sms recipient is active. But if the recipient number is not active then the sms will be stored (*forward*) in SMSC until the recipient number is active within a certain time. So that within a certain time the destination number is not active, the sms will automatically be deleted by SMSC.

Communication between the user and the system, an important component is the use of GSM modules via Wireless such as figure 2. The use of this modem module is used to communicate the safety system in the form of sms with the user in the event of abnormal vehicle usage. Modem comes from the word *modulator* and *demodulator*. *Modulate* is the process of translating data from digital to analog so that it can be transmitted. *Demodulate* is the process of translating from analog to digital. The modulator is the part that converts the information signal into a carrier signal and is ready to be transmitted, while the demodulator is the part that separates the information signal (which contains data or messages) from the received carrier signal so that the information can be received properly. The use of the wavecom module can be connected to the controller using AT-Commad as a command in sending data [5].



Figure 2. GSM Communication produced by Wavecom.Inc

Vehicle security system using GPS with telegram application communication [6]. The use of *AT-Command* that must be considered is what *commands* must be entered at the terminal, what actions must be taken after the *command* is entered into the terminal and the last is to know what response is obtained after getting the *command* entered. AT commands must be in the format "AT <x> <n>" where x is the command and n is the argument [7].

**Table 1.** AT Command

Command	Function
AT	Checking if the modem is connected
AT+CMGF	To set the <i>mode</i> format of the terminal
AT+CSCS	To set the <i>encoding</i> type
AT+CNMI	To automatically detect new incoming SMS messages
AT+CMGL	Open the SMS list on the SIM card
AT+CMGS	Sending sms messages
AT+CMGR	Reading sms messages
AT+CMGD	Delete sms packets

### 1.2 Vehicle Ignition System

The CDI ignition system (*Capacitor Discharge Ignition*) is a motorcycle ignition system that uses CDI DC (direct current). CDI DC is a system that uses current sourced from batteries [8].

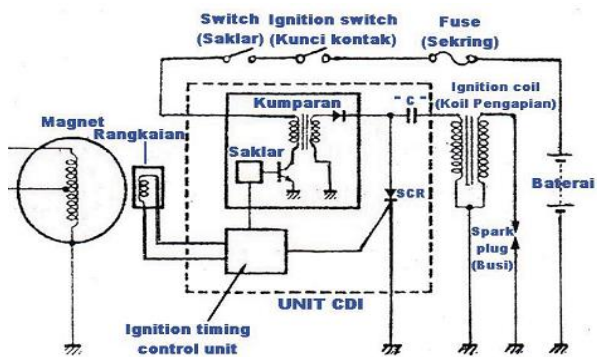

**Figure 3.** Ignition system with CDI

This research has the aim of designing and making a motorized vehicle safety system. This vehicle safety system is designed to minimize the danger of vehicles from theft. The safety system can be connected to the vehicle ignition system and by utilizing an SMS connection.

## 2. Materials and Methods

### 2.1 Vehicle Safety System

This research uses the design method in order to make this system *hardware*. The materials and equipment used are 1 unit of ATmega 8535 microcontroller minimum system, 1 unit of wavecom type modem, 2 units of relay driver circuit, Optocoupler, Pulse generator (crystal), IC 7805, 1 alarm unit, 1 unit of Honda Supra 125 motorcycle, *Toolset*, *Downloader* cable, Windows operating system computer, CV Avr software (*Code Vision Avr*), Hand Phone. The block diagram

and flowchart of the safety system are as shown in Figure 4 and Figure 5.

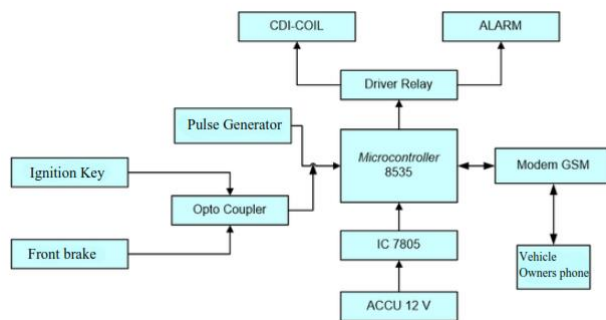

**Figure 4.** Block diagram

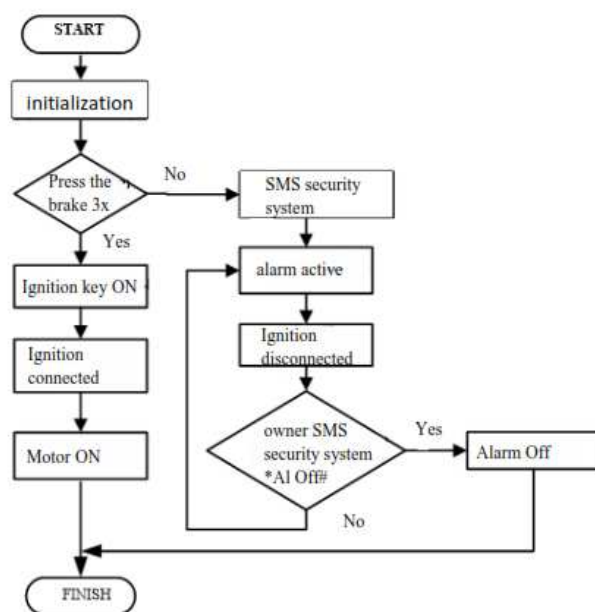

**Figure 5.** Flowchart of the safety system

### 2.2 Tool Testing

Testing of this vehicle safety device is carried out to determine the quality of the tools made and testing all aspects to secure the vehicle through providing information when the motor is stolen, the alarm sounds and disconnects the ignition system. The tests were carried out as follows:

- Testing the modem connection and the ability of the alarm to turn on when stolen and turn off the alarm with sms based on distance, namely 100m, 200m, 300m, 400m and 500m with units of time.
- Testing the system's ability to turn off the motor ignition.

### 3. Results and Discussion

Hardware design in a motor vehicle security system has been successfully made. This vehicle safety can secure motorized vehicles when the vehicle is parked. The picture of the design results as in Figure 6.



Figure 6. Motor vehicle security system

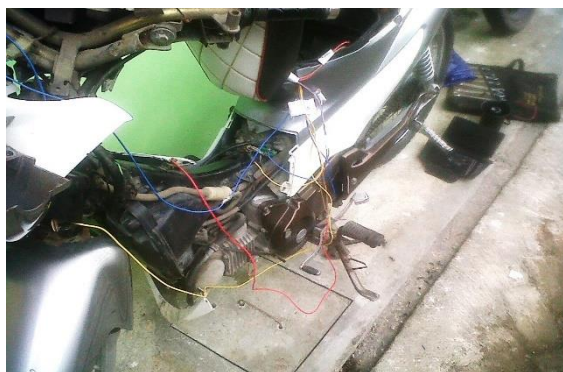

Figure 7. security system

The main components of making this vehicle safety system *hard ware* are:

1. ATmega 8535 *microcontroller* minimum system

This system has a function to process system data containing instructions to be sent to the vehicle owner or vice versa and communication with the motor (as the brain of the safety system).

2. GSM Modem

Serves for data transmission media between the vehicle owner and the security system or vice vers.

3. Relay

Serves to connect and disconnect the current from the electrical system on the

vehicle automatically. Relay works as a switch that is obtained from *its input*.

4. Alarm

This alarm has a function to notify when there is danger (theft) so that the alarm can notify people around that the vehicle is in an unsafe condition.

#### 3.1 Design with CV Avr program

Before the vehicle safety device is assembled, first make a program that will be entered into the *microcontroller*. The program is a command that is in accordance with the design (*input* or *output*). The following is a program *flowchart* that contains the workflow of the vehicle safety system.

The vehicle safety system that has been completed both *hardware* and *software*, can be implemented in accordance with the design of the command or can find out the condition of the vehicle when normal or abnormal use. The *microcontroller inputs* used for the safety system include the front brake (press 3 times), the vehicle owner sms safety system with the format \*ALOFF# and ignition key. On a motorcycle when normal use is first done is to press the front brake lever 3x, so that the brake will send a signal to the *microcontroller* and *the microcontroller* will process the input data from the front brake pulse and execute the signal given input, then the motor will start normally. When the usage is abnormal without pressing the brake lever 3x, the *input* from the ignition key sends a signal to the *microcontroller* that there has been a theft. This is because the *microcontroller* has been programmed to know the *input* and *output*, so that the system can work to execute the program that has been made. The *output* of the system can work when there is theft (abnormal usage), successively *the microcontroller* will instruct the alarm relay *driver* to sound and cut off the ignition system line. This is because in the safety system circuit there is a relay where the relay is designed as an alarm controller, breaker and ignition system line connector. The safety system circuit diagram can be seen in Fig 8.

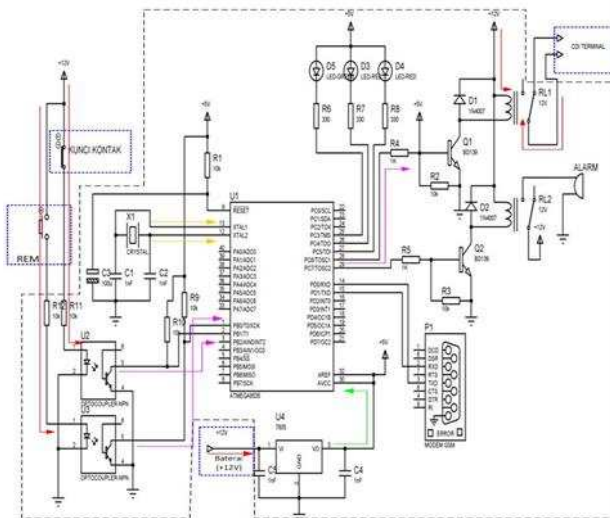

**Figure 8.** Safety System Circuit Diagram

Figure 8 shows the normal and abnormal usage circuit. *Power supply* from the battery (+12V) goes to the regulator IC 7805, then the voltage will change to 5V as a *microcontroller power supply* (AVCC). The front brake lever is pressed 3X, the ignition key is on, then the current will go to the optocoupler, in the optocoupler getting a 12V voltage, the LED in the optocoupler component will turn on so that the light-sensitive transistor component will connect the transistor, after which the optocoupler sends a logic 1 *input* to the *microcontroller* (PB0 and PB1). When the *microcontroller* works, it will be assisted by an *external crystal* to stabilize the *microcontroller's* work (XTAL1 and XTAL2). The *input* that has been processed by the *microcontroller* will be sent in the form of an *output* (PC6) which is logic 1 to the relay *driver*, then the relay *driver* will connect the ignition system (*connecting the cdi-coil*).

In the abnormal usage circuit (without pressing the front brake lever 3X). *Power supply* from the battery goes to the regulator IC 7805 to the *microcontroller* (AVCC). When the ignition key is on, it sends current to the optocoupler to give logic 1 *input* to the *microcontroller* (PB1). When the *microcontroller* works, it will be assisted by an *external crystal* to stabilize the *microcontroller's* work (XTAL1 and XTAL2). *Input* that has been processed by the *microcontroller* will be sent in the form of *output* (PC7) to the alarm and *output* (PD0 and PD1). At the *output* (PC7) has a logic 1, which in this logic will instruct the relay *driver* to connect to the alarm so that the alarm will sound. The alarm

has a voltage source from the battery (+12V). At the *output* (PD0 and PD1) will connect serial data to the modem on the TXD and RXD *ports*, so that when there is theft, the modem will send information to the vehicle owner and vice versa.

### 3.2 Modem Connection Testing

Modem testing aims to determine the process of transmitting data in the form of sms through a *microcontroller* with modem media. In the *microcontroller* block and modem block there are two serial communications, namely Tx and Rx. The serial port on the modem is connected to the serial port on the *microcontroller*. The *input* and *output* on the *microcontroller* aims to determine communication with the motor and vehicle owner. After that, the most important thing for the program to communicate with the vehicle owner is the *AT-command*. The contents of the *AT-command* are the *cell phone* number and the contents of the sms which are arranged in *text mode* format. This sms is an *asynchronous message* data type. In *asynchronous* mode each ppherical has its own *clock* source so that in this mode it only requires 2 pins, namely the TxD pin and the RxD pin. This test was conducted by the user between Gang Terong Kemiling, Bandar Lampung and vehicles in BKP (Bukit Kemiling Permai) by simulating the motor vehicle security system when the vehicle was stolen, then the vehicle owner will get a report if someone wants to steal his vehicle and normal use. Distance variations between vehicles parked by users and vehicle owners 100m, 200m, 300m, 400m and 500m. The vehicle owner tests the modem by simulating the position of the stolen vehicle, namely the information (sms) of the security system to the vehicle owner. During the simulation, the security system successfully sent a report to the owner that the vehicle was being stolen. Modem testing table as in table 2

**Table 2.** Modem Connectivity Testing.

No.	Distance	Owner sms	Sms safety system	Results
1.	100 m	-	SOMEONE STOLE YOUR BIKE... !!!!	Success
		*A1 off#	ALARM OFF OK	Success
2.	200 m	-	SOMEONE STOLE YOUR BIKE... !!!!	Success
		*A1 off#	ALARM OFF OK	Success
3.	300 m	-	SOMEONE STOLE YOUR BIKE... !!!!	Success
		*A1 off#	ALARM OFF OK	Success
4.	400 m	-	SOMEONE STOLE YOUR BIKE... !!!!	Success
		*A1 off#	ALARM OFF OK	Success
5.	500 m	-	SOMEONE STOLE YOUR BIKE... !!!!	Success
		*A1 off#	ALARM OFF OK	Success

### 3.3 Disconnecting the vehicle ignition system

Turning off the vehicle ignition system and alarm on the safety system is given 2 relays, namely for the alarm and ignition system lines. Relay serves as a medium for testing the connectivity of connecting the vehicle electrical system track, namely in the ignition system path between the CDI connection with the coil and while the relay for the alarm serves to turn on or turn off the alarm. If the microcontroller gives logic 1 then the relay will be connected and if the *microcontroller* gives logic 0 then the relay will break.

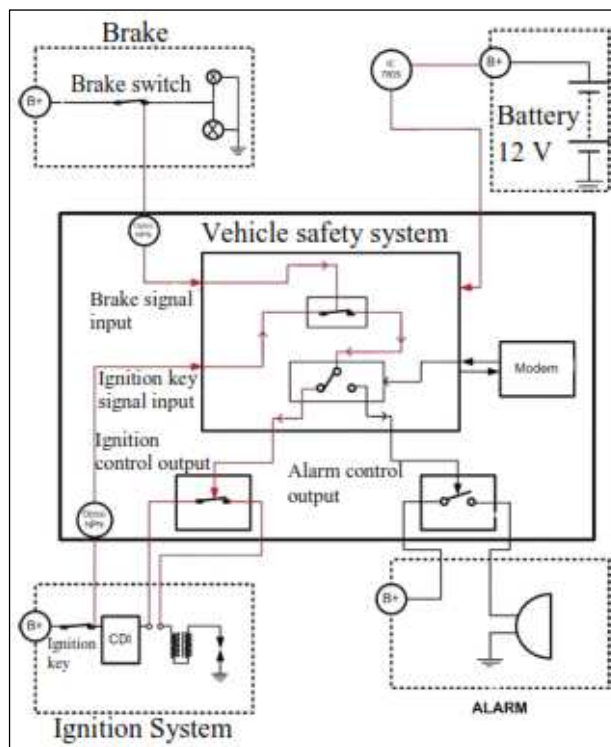

(a)

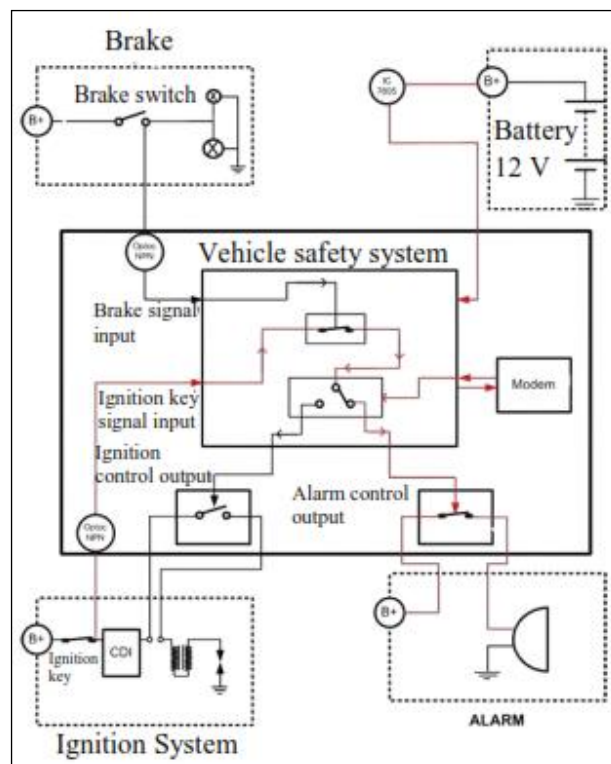

(b)

**Figure 9.** a). Normal Condition; b). Abnormal Condition

Figure 9 is the overall flow of the safety system under normal conditions (1) and abnormal conditions (2). The *microcontroller* gets its voltage source from the battery (B+), the 12V battery voltage is converted by IC 7805 into a 5V voltage. This is because the *microcontroller* only needs 5V voltage. The work flow of the vehicle safety system under normal conditions in Figure 5 is when the front brake is pressed 3X, the switch will be connected, then go to the NPN optocoupler (Optoc NPN) to provide *input* to the *microcontroller*. The ignition key is ON, then the ignition key will also provide *input* to the *microcontroller*. Both *inputs* are processed by the *microcontroller* according to the program. Then the *microcontroller* will read that the usage conditions are normal. The CV Avr program can be analogous to a switch because its use is in accordance with the programmed needs. After the *microcontroller* reads normal conditions, it then gives *output* to the relay *driver* switch and the ignition system will be connected. While the alarm relay *driver* is not connected (the alarm does not sound). In this condition, the GSM modem does not work. This is because the commands in the CV Avr program as the system controller flow. The relay *driver* switch is connected or not connected depending on the *input* from the *microcontroller*.

**Table 3.** Testing the ability of the system to control the motor

Press the front brake 3x	Contact Stops	Alarm	SMS System	Motor Condition Description	Results
Yes	On	No sound	-	-	Motor starts
No	On	Sound	Someone Stole Your Motorcycle...!!!!	Motorcycle stolen	Ignition system is off (motor stalls)

On a motorcycle when normal use, the first thing to do is press the front brake lever 3x, so that the brake will send a signal to the *microcontroller* and the *microcontroller* will process the input data from the front brake pulse and execute the signal given input, then the motorbike will start normally. When the usage is abnormal without pressing the brake lever 3x, the *input* from the ignition key

sends a signal to the *microcontroller* that there has been a theft. This is because the *microcontroller* has been programmed to know the *input* and *output*, so that the system can work to execute the program that has been made. The *output* of the system can work when there is theft (abnormal usage), successively the *microcontroller* will instruct the alarm relay *driver* to sound and cut off the ignition system line. This is because in the safety system circuit there is a relay where the relay is designed as an alarm controller, breaker and ignition system line connector.

#### 4 Conclusion

Based on the results of the research, a sms-based vehicle security system was produced. From this research, it can be concluded that this sms-based vehicle safety system was successfully made and can secure the vehicle when the vehicle is stolen. This motorized vehicle safety system can be used properly so that this research needs development. Furthermore, information from expert examiners and prospective users of this vehicle safety system suggest for development in overcoming the weaknesses of this tool that should be in securing the vehicle this tool is added with a system that can track when the vehicle is stolen (with GPS) and there needs to be development so that it does not depend on the signal from the provider used and there needs to be a minimalist hardware design development so that the safety placement can be placed in the gaps of the vehicle.

#### References

[1] RMOLLampung. (2023). Bandar Lampung Police handled 4,476 cases throughout 2023. RMOL Lampung.RMOLLampung. <https://www.rmollampung.id/polresta-bandar-lampung-tangani-4476-kasus-sepanjang-tahun-2023>.

[2] A. Junaedi, M. D. M. Puspitasari, and M. Maulidina. (2021). Pengaruh (Intensor) Induktor Heater Menggunakan Thermal Sensor Berbasis Mikrokontroler Arduino Nano Dalam Mengolah Logam, *Nusantara of Engineering (NOE)*. 4(2), pp. 169–175 doi: 10.29407/noe.v4i2.16754.

[3] J. Dewanto and F. (2021) Tanuwijaya. Sistem Pengaman Sepeda Motor Anti Begal. *Jurnal Teknik Mesin*, 17(1), pp. 6–10. doi: 10.9744/jtm.17.1.6-10.

- [4] D. T. Pandiangan (2021). Perancangan Sistem Alat Kontrol Lampu menggunakan Perintah SMS dengan Modul GSM SIM 8001 berbasis Metode Arduino. *JUKI : Jurnal Komputer dan Informatika*. 3(2), pp. 52–58. doi: 10.53842/juki.v3i2.61.
- [5] Nurul Chafid and Zulkifli. (2022). Sistem Keamanan Brankas Menggunakan Kunci Otomatis Dengan SMS. *Jurnal Satya Informatika*. 6(2), pp. 40–55. doi: 10.59134/jsk.v6i02.27.
- [6] M. F. Ferdhiansyah, N. Y. D. Setyaningsih, and M. Dahlan (2022). Physical Touch Code Sistem Pengaman Sepeda Motor Menggunakan GPS,” *Pseudocode*. 10(2), pp. 97–105. doi: 10.33369/pseudocode.10.2.97-105.
- [7] W. Budiharto. (2009). *Smart Control Based on SMS/Web/TCP-IP*. Jakarta: PT Elex Media Komputendo.
- [8] Kurniawan Rahmanto. (2024). Pengaruh Pemakaian CDI Type DC Terhadap Performa Mesin Kendaraan Honda Supra 100cc. *Mars : Jurnal Teknik Mesin, Industri, Elektro Dan Ilmu Komputer*. 2(1), pp. 01–18. doi: 10.61132/mars.v2i1.43.



This is an open-access article distributed under the terms of the Creative Commons Attribution 4.0 International License (CC-BY).