

# Hydrogen Generator Design Using Motorcycle Electricity Source

Jalu Nur Septiyanto

Mechanical Engineering Study Program, Faculty of Industrial Technology, National Institute of Technology

Email: jalunur15@gmail.com

Received: 2025-03-03 Received in revised from 2025-05-17 Accepted: 2025-05-22

## Abstract

The global energy crisis has led to a spike in crude oil prices that has had a significant impact on the world economy. Indonesia, as a country facing a real energy crisis, is experiencing increasing energy consumption and decreasing availability of primary fossil energy. To overcome this problem, people are expected to save fuel by reducing the use of private vehicles. This research aims to develop a hydrogen generator model that uses electricity from motorbikes as an effort to save fuel. The hydrogen generator is designed with several sample models, the first using 4 stainless steel plates, the second 8 stainless steel plates and the third 12 stainless steel plates by connecting two electrolytic cells in parallel. In the experiments, the number of stainless steel anode and cathode plates was varied and the voltage was set at 12 voltages and 6 amperes of current, and tested using 2 methods, namely water and water with baking soda to evaluate the effect on hydrogen production. The results showed a certain trend in hydrogen production related to the variation of the parameters tested and the most effective in this test is 4 plates of water (800 ml) with 10 grams of baking soda and 8 plates of water (800 ml) with 10 grams of baking soda on the manometer gauge an increase of 1 ml.

**Keywords:** *Effective; Fuel; Hydrogen generator; Savings*

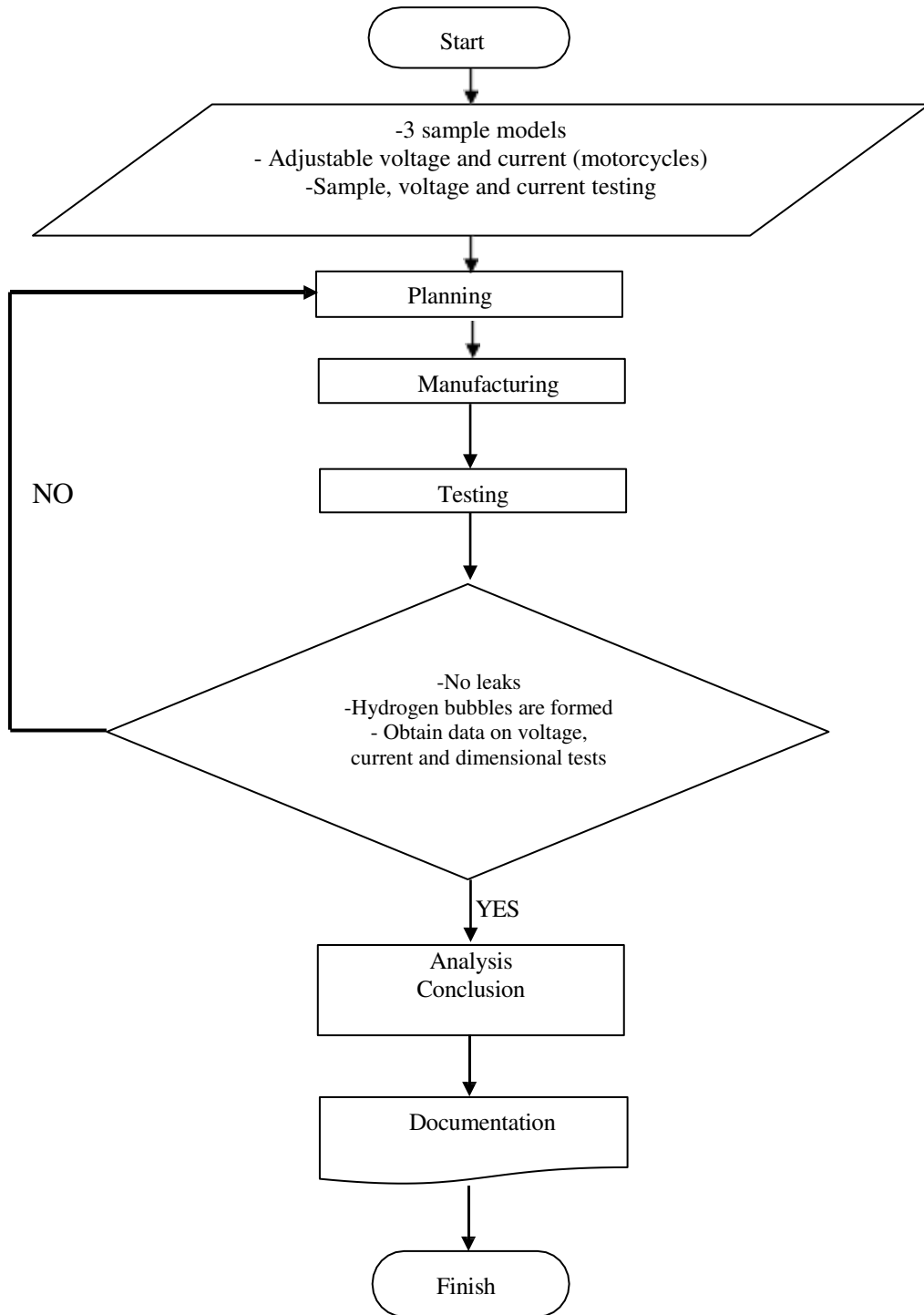
## 1. Introduction

The energy crisis affecting the world has led to high global crude oil prices. This directly impacts economic activities. Indonesia faces an increasingly evident energy crisis due to rising energy consumption and the depleting availability of primary fossil energy. With the rapid advancement of transportation technology innovations, the demand for fuel oil has become a necessity that the government must fulfill to maintain economic stability for society. Meanwhile, in Indonesia, dependence on fossil fuels remains very high, especially for fuel oil from year to year. This is based on the projected total energy demand data from 2010 to 2030, while fuel oil production continues to decline annually. On one hand, fuel oil consumption remains the largest in Indonesia, especially for Diesel and Otto engine usage [1].

Therefore, the people in Indonesia must conserve fuel by reducing the use of private vehicles. One fuel-saving effort is by mixing fuel oil with H<sub>2</sub> produced from electrolysis using a hydrogen generator device. Hydrogen has been developed where two electrolyte cells are connected in parallel. This research will create a hydrogen generator model that can utilize electricity from motorcycles. The resulting device will be tested to observe the tendency of hydrogen production by varying the number of anode and cathode plates as well as variations in voltage and electric current.

## 2. Method

### 3.1. Flowchart Diagram



**Figure 1. Flowchart diagram**

#### Explanation of Flowchart

Below is the explanation of the flowchart shown in the Figure 1:

#### 1. Design Creation

In this hydrogen generator research, there will be three sample models.

2. Component Preparation

The components for constructing the hydrogen generator must be assembled according to the design.

3. Measuring Instruments

The measuring instrument used in this test is a U-manometer to measure the increase in hydrogen produced by the wet cell hydrogen generator during testing.

4. Testing

The testing is conducted by observing voltage and current while the device operates. There are three sample models in this test: the first with 4 plates, the second with 8 plates, and the third with 12 plates.

5. Data Recording

After conducting the tests, the data is recorded for further analysis.

6. Analysis and Conclusion

The obtained data is analyzed to determine the optimal hydrogen production, which is then processed to draw conclusions from the wet cell hydrogen generator testing.

2.2. Wet cell Hydrogen Generator Scheme

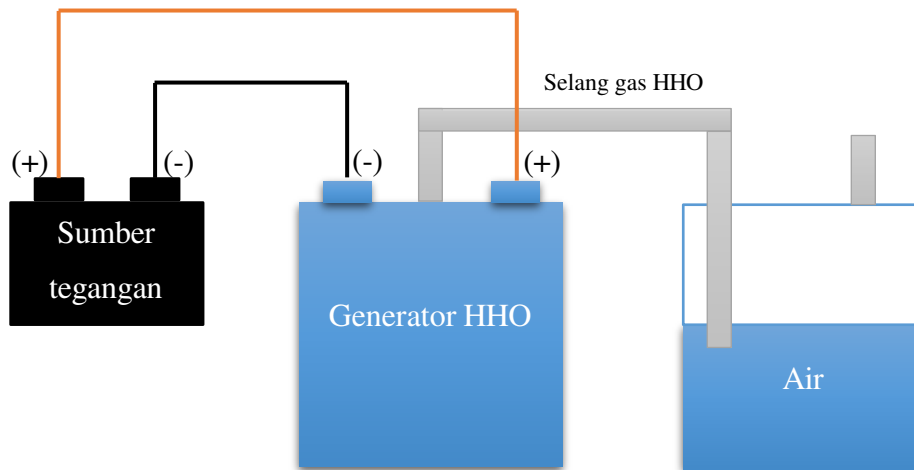


Figure 2. Schematic of a wet cell hydrogen generator

2.3. Research Location

The research location is in the workshop. Because most of the work is done in the workshop, such as cutting using a hand grinder, making holes using an 8 mm and 6 mm drill and measuring using a caliper.

2.4. Draft Cost Budget

Table 1. Draft cost budget

No.	Item Name	Quantity	Price
1	Stainless steel	Per kilogram, size 1.08 m	70,000
2	AWG Cable	Per meter	3,500
3	Straight Pneumatic Hose Fitting (Slip Lock)	Unit, size 8mm	24,000
4	Elbow Pneumatic Hose Fitting (Slip Lock)	Unit, size 8mm	24,000
5	Pneumatic Hose	Per meter, size 8mm	10,000
6	Plastic Jar	Unit, size 155mm x 115mm x 125mm	36,000
7	Plastic Insulator	-	2,000
8	Catalyst Liquid	1 kg	14,500
9	M8 Bolt	Unit, size 8mm	4,000
10	M6 Bolt	Unit, size 6mm	3,500
11	U-Manometer	-	130,000
12	Power Supply	1 unit	860,000
	<b>Total</b>		<b>1,181,500</b>

### Characteristics of Stainless Steel

#### 1. Corrosion Resistance

Type 304 has excellent corrosion resistance in various environments and when in contact with different corrosive media. Pitting and crevice corrosion may occur in environments containing chloride. Stress corrosion cracking can occur at temperatures above 60°C.

#### 2. Heat Resistance

Type 304 has good oxidation resistance in intermittent use up to 870°C and continuous use up to 925°C. However, continuous use at temperatures between 425-860°C is not recommended. In such cases, 304L is recommended due to its resistance to carbide precipitation. Where high strength is required at temperatures above 500°C and up to 800°C, grade 304H is recommended. This material will maintain its water corrosion resistance.

#### 3. Chemical Composition

Table 2 shows the chemical composition.

**Table 2. Chemical Composition**

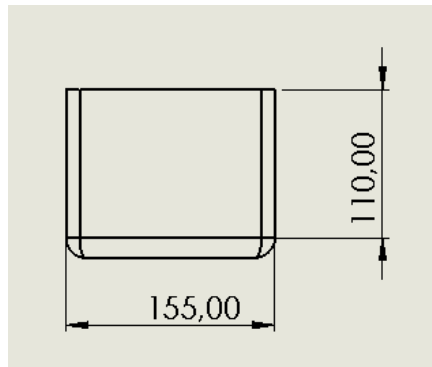
Element	% (Percentage)
Carbon (C)	0.07
Chromium (Cr)	17.50-19.50
Manganese (Mn)	2.00
Silicon (Si)	1.00
Phosphorus (P)	0.045
Sulfur (S)	0.015
Nickel (Ni)	8.00-10.50
Iron (Fe)	Balance
Nitrogen (N)	0.10

### 2.5. Tool Design

The design of the wet cell hydrogen generator must be adjusted to the component requirements below:

#### 1. Square Jar

The size of the box jar is 125 mm high, 115 mm wide and 155 mm long. Figure 3.4 shows the design of a square jar.



- [1] S. Li, B. Ragu-Nathan, T. S. Ragu-Nathan, and S. Subba Rao, "The impact of supply chain management practices on competitive advantage and organizational performance," *Omega*, vol. 34, no. 2, pp. 107–124, 2006, doi: 10.1016/j.omega.2004.08.002.
- [2] G. Monahan, *Enterprise Risk Management: A Methodology for Achieving Strategic Objectives*. John Wiley & Sons, 2012. [Online]. Available: <https://onlinelibrary.wiley.com/doi/full/10.1002/9781119197546.ch1%0Ahttps://onlinelibrary.wiley.com/doi/abs/10.1002/9781119197546.ch1%0Ahttps://onlinelibrary.wiley.com/doi/10.1002/9781119197546.ch1>
- [3] R. Stupp, M. E. Hegi, M. R. Gilbert, and A. Chakravarti, "Chemoradiotherapy in malignant glioma: Standard of care and future directions," *J. Clin. Oncol.*, vol. 25, no. 26, pp. 4127–4136, 2007, doi: 10.1200/JCO.2007.11.8554.

- [4] K. Verweir, “Integrated Performance Management: A Guide to Strategy Implementation,” *Strateg. Dir.*, vol. 22, no. 8, pp. 916–920,, doi: 10.1108/sd.2006.05622hae.001.
- [5] Yatena, I. W. Prianto, R. D. Febila, N. D. Handayani, A. C. A. Salsabila, and P. D. Sagita, *SUPPLY CHAIN MANAGEMENT: Strategi Pengelolaan Persediaan Yang Efektif*, vol. 44, no. 8. 2011. doi: 10.1088/1751-8113/44/8/085201.
- [6] W. Ho, T. Zheng, H. Yildiz, and S. Talluri, “Supply chain risk management: A literature review,” *Int. J. Prod. Res.*, vol. 53, no. 16, pp. 5031–5069, 2015, doi: 10.1080/00207543.2015.1030467.
- [7] A. Y. Alam, “Steps in the Process of Risk Management in Healthcare,” *J. Epidemiol. Prev. Med.*, vol. 02, no. 02, p. 118, Oct. 2016, doi: 10.19104/jepm.2016.118.
- [8] R. Magdalena, “Analisis Risiko Supply Chain Dengan Model House of Risk (Hor) Pada Pt Tatalogam Lestari,” *J. Tek. Ind.*, vol. 14, no. 2, p. 53, 2019.
- [9] C. S. Tang, “Perspectives in supply chain risk management,” *Int. J. Prod. Econ.*, vol. 103, no. 2, pp. 451–488, 2006, doi: 10.1016/j.ijpe.2005.12.006.
- [10] D. Rizki, F. H. Noor Athief, and D. Puspitaningrum, “Penerapan Manajemen Risiko Terhadap Pembiayaan Bermasalah Pada Masa Pandemi Covid-19,” *Al Iqtishod J. Pemikir. dan Penelit. Ekon. Islam*, vol. 10, no. 2, pp. 16–36, 2022, doi: 10.37812/aliqtishod.v10i2.525.
- [11] J. K. Jain, G. S. Dangayach, G. Agarwal, S. Banerjee, and P. Dey, “Selection of end user in supply chain network using Fuzzy-Pareto approach,” *Proc. 1st Int. Technol. Manag. Conf. ITMC 2011*, pp. 302–308, Jun. 2011, doi: 10.1109/ITMC.2011.5995957.
- [12] S. Ratnasari, M. Hisjam, and W. Sutopo, “Supply chain risk management in newspaper company: House of risk approach,” in *AIP Conference Proceedings*, 2018, p. 30016. doi: 10.1063/1.5024075.
- [13] I. N. Pujawan, M. Er, and Maya, *Supply chain management (Edisi 3)*, 3rd ed. Yogyakarta: Andi Offset, 2017.

2. Stainless Steel

Stainless steel plate with code 304 because there are many on the market, this plate is tall in size with a ratio of 1.1, namely 80 mm high and 80 mm wide. The size of the holes in the stainless steel is 8 mm and 6 mm in diameter due to adjusting the space in the box jar. Figure 4 is a stainless steel plate design.

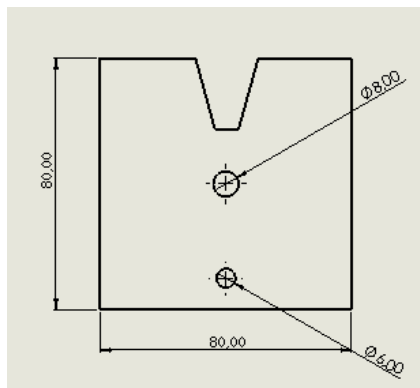
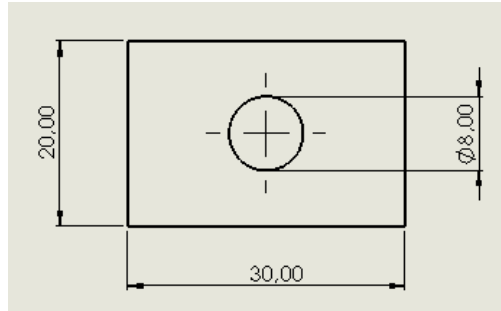


Figure 4. Stainless steel

3. Plastic Insulator

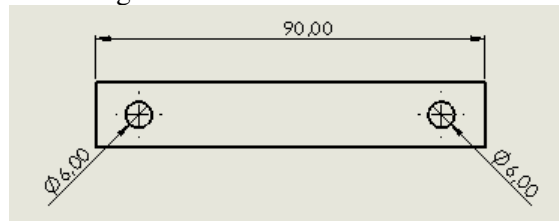
Plastic insulators use PVC (Polyvinyl chloride) because they can withstand heat, this insulator has a height of 2 mm and a width of 30 mm. Its function is to neutralize the existing electric current. The size of the hole in the plastic insulator adjusts to the hole in the stainless steel plate so that it fits when the bolt is installed to connect the plate and insulator. Figure 5 is a plastic insulator design.



**Figure 5. Plastic Insulator**

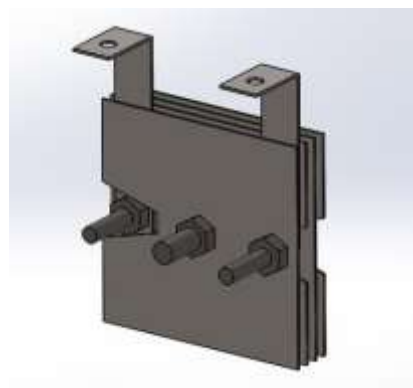
4. Bolt holder

This bolt holder is to connect the plate to the existing jar, the size is 6 mm with a length of 90 mm. Figure 6 shows the bolt holder design.

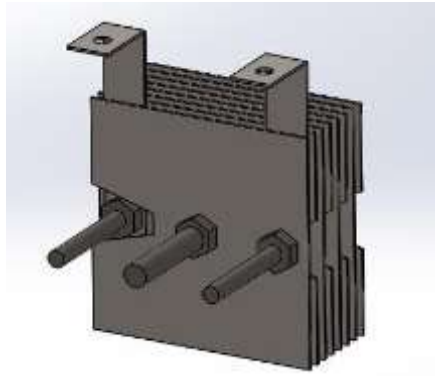


**Figure 6. Bolt Holder**

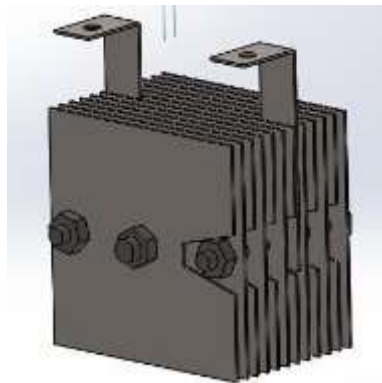
5. Results of the design using 4, 8 and 12 stainless steel plates



**Figure 7. Stainless Steel Plate Model**



**Figure 8. Model 8 Stainless steel plate**



**Figure 9. Model 12 stainless steel plates**

## 2.6. Research Tools and Materials

### Research Tools

The following are the tools used in this research:

#### 1. Hydrogen Generator

The HHO generator is the main component that functions as a producer of Brown Gas or HHO Gas. Where the generator used is a wett cell type HHO generator.

- **Stainless Steel Plat**

The plates used varied from 4, 8 and 12 plates in this study. Figure 10 shows a stainless steel plate.



**Figure 10. Stainless Steel Plat**

- **Nuts and Bolts**

Used to unite plate 1 with the other plates and to connect it to the jar so it doesn't leak. Figure 11 is a bolt.



**Figure 11. M6 bolt**



**Figure 12. M6 Bolt**

- **Plastic Insulator**

This insulator functions to provide a gap between each plate. Where in this study an insulator with a diameter of 20 mm x 30 mm and a thickness of 1 mm was used. Figure 13 below shows a plastic insulator.



**Figure 13. Plastic Insulator**

## 2. Power Supply

A power supply is an electronic device whose function is to provide and manage electrical resources. This device converts and adjusts the electric voltage from the main power source (such as the AC power network) into a voltage that suits the needs of a device, either in the form of direct current (DC) or alternating current (AC). In the context of hydrogen generators using the electrolysis method, the power supply plays a crucial role in providing stable voltage and current **for** an effective and efficient electrolysis process. Typically, a power supply with adjustable voltage and current is required to ensure optimal hydrogen production efficiency. Figure 14 shows the power supply.



**Figure 14. Power Supply 32 V 10 A**

### 3. Elektrolit Cointainer

The Electrolyte Container is a plastic jar used to hold the electrolyte solution. In this study, there are two containers: the first is used to hold the electrolyte solution that will enter the HHO generator, and the second is used to collect the remaining electrolyte from the water electrolysis reaction and the HHO gas output that will flow into the measuring volume tube. Two containers are used to ensure that the catalyst mass fraction remains unchanged. Figure 15 shows the electrolyte container.



**Figure 15. Jar**

### 4. Hose

The hose is used to flow the electrolyte solution both in and out of the HHO generator. The hose sizes used are 8 mm and 6 mm in diameter. Figure 16 shows a pneumatic hose.



**Figure 16. Pneumatic Hose**

### 5. Digital Multimeter

A digital multimeter is a measuring instrument used to measure quantities such as voltage, current and resistance in electrical circuits. Apart from that, it is also an electronic test tool that measures AC/DC voltage by providing readings in digital numerical mode. Used to measure the voltage and current (A) flowing in the electrolyzer (HHO generator). Figure 17 is a digital multimeter.



**Figure 17. Digital Multimeter**

6. Stopwatch

Functions to measure time when collecting data.

7. Glue

Functions to glue if there is a leak in the hydrogen generator. Figure 18 shows the glue.



**Figure 18. Glue**

8. Baking Soda

Serves to speed up electrolysis. Specifications for baking soda or baking soda include:

- Constituent elements: Sodium (Na), hydrogen (H), carbon (C), and oxygen (O) in a ratio of 1:1:1:3
- Form: White crystals or powder
- Properties: Alkaline
- Solubility: Soluble in water. Figure 19 is baking soda.



**Figure 19. Baking Soda**

9. Rubber O-ring

To close the gap between the bolt and the jar to prevent leaks. Figure 20 shows a rubber-oring.



**Figure 20. Rubber O-ring 6 mm**

#### 10. Plastic Bolts

Functions as a neutralizer between the cathode and anode to prevent short circuits. Figure 21 below is a plastic bolt.



**Figure 21. Plastic Bolts 8 mm**

#### 11. AWG Cable

Functions to flow voltage and current from the power supply to the hydrogen generator. Figure 22 is an AWG cable.



**Figure 22. AWG Cable**

#### 12. Pneumatic Thread Fittings

To connect the hose on the hydrogen generator to the separating jar between H<sub>2</sub>O and O<sub>2</sub>. Figure 23 below shows a pneumatic thread fitting.



**Figure 23. Pneumatic Thread Fittings**

13. Seal tape

To coat threads on bolts or fittings. Figure 24 is a seal tape.



**Figure 24. Seal tape**

**3. Results and Discussion**

The HHO generator is the main component that functions as a producer of Brown Gas or HHO Gas. Where the generator used is a wet cell type HHO generator.

**Table 3. Test results of wet cell type hydrogen generator**

No	Number of Plates	Medium (800 ml)	Voltage	Current	Leakage	Bubble Formation Time	U Manometer Result
1	4 plates	Water	Constant	Decreased from 6.000 to 0.947	No leakage	6 minutes	None
2	4 plates	Water + 10 g baking soda	Decreased from 12.00 to 5.71	Constant	No leakage	7 seconds	Increased by 1 ml
3	8 plates	Water	Constant	Decreased from 6.000 to 1.331	No leakage	3 minutes	None
4	8 plates	Water + 10 g baking soda	Decreased from 12.00 to 5.07	Constant	No leakage	4 seconds	Increased by 1 ml
5	12 plates	Water	Constant	Decreased from 6.000 to 1.429	No leakage	2 minutes 50 seconds	None
6	12 plates	Water + 10 g baking soda	Decreased from 12.00 to 4.25	Constant	No leakage	3 seconds	None

The performance test results of the hydrogen generator, based on variations in the number of electrolysis plates and the type of electrolyte solution, indicate that both parameters significantly affect gas production efficiency. When using pure water as the electrolyte medium, increasing the number of plates from 4 to 8 and then to 12 resulted in improved electrical efficiency, as shown by a decrease in current from 6.000 A to 0.947 A, 1.331 A, and 1.429 A, respectively. Despite a constant voltage, the time for the initial bubble formation also decreased with more plates 6 minutes with 4 plates, 3 minutes

with 8 plates, and 2 minutes 50 seconds with 12 plates. However, the U-manometer readings remained unchanged, indicating that gas formation was still at an early stage or had not reached a measurable pressure level. These findings are consistent with research by [2], which demonstrated that increasing the surface area and the number of electrodes can significantly enhance the efficiency and stability of hydrogen production in wet-cell HHO generators. Similarly, [3] reported that the application of broader electrode surfaces and optimized electrical input contributes to improved hydrogen output through electrolysis. Another relevant study by [4] showed that the use of stainless steel electrodes with optimized spacing and consistent voltage results in measurable increases in gas volume, although pressure effects may take longer to manifest in closed systems. These references affirm that increased electrode area and efficient current distribution play a pivotal role in the electrolysis process, especially when pure water is used as the electrolyte.

The addition of 10 grams of baking soda to the water medium consistently improved the efficiency of the electrolysis process compared to using pure water alone. This is evident from the significant voltage drop from 12.00 V to 5.71 V (4 plates), 5.07 V (8 plates), and 4.25 V (12 plates) while the current remained constant. Notably, bubble formation occurred much faster with the baking soda solution: only 7 seconds (4 plates), 4 seconds (8 plates), and 3 seconds (12 plates). Moreover, the U-manometer readings showed a 1 ml increase in pressure for the 4 plate and 8 plate configurations, indicating more intense electrolysis and gas accumulation within the system. These findings align with research by [5], who demonstrated that using  $\text{NaHCO}_3$  as a catalyst in well water electrolysis significantly enhances HHO gas production efficiency. Their study found that optimal electrode spacing and  $\text{NaHCO}_3$  concentration led to faster gas generation and improved energy efficiency. Similarly, [6] reported that adding sodium bicarbonate to seawater electrolytes not only extended the operational time of a 3-watt LED lamp but also reduced electrode corrosion rates, indicating improved electrolysis performance. Furthermore, a study published in the *Jurnal Chemurgy* [7] highlighted that the use of  $\text{NaHCO}_3$  in electrolysis processes increases hydrogen gas production rates and overall system efficiency.

Overall, the data demonstrate that increasing the number of plates and using baking soda as an electrolyte enhance the hydrogen generator's performance in terms of electrical efficiency and reaction speed. The significant current drop in pure water tests reflects better electrical efficiency as more plates are added. Meanwhile, the substantial voltage reduction in baking soda solutions indicates lowered electrolyte resistance and accelerated electrolysis. The absence of leakage across all tests confirms that the system functioned safely and was properly sealed. Therefore, the 12 plate configuration with added baking soda can be recommended as the optimal design for efficient hydrogen production in terms of both time and energy consumption. These findings align with research by [8], which demonstrated that increasing the electrode surface area and electrolyte concentration significantly enhances hydrogen gas production through electrolysis. Their study found that larger electrode areas and higher electrolyte concentrations led to increased gas volumes, highlighting the importance of these parameters in optimizing electrolysis efficiency. Similarly, a study by [9] reported that adding sodium bicarbonate to seawater electrolytes not only extended the operational time of a 3-watt LED lamp but also reduced electrode corrosion rates, indicating improved electrolysis performance. Furthermore, research by [10] demonstrated that variations in the number of electrodes and types of catalysts, including the use of baking soda, significantly affect hydrogen gas production during seawater electrolysis. Their findings support the conclusion that optimizing electrode configurations and electrolyte composition is crucial for enhancing hydrogen production efficiency.

#### 4. Conclusion

This study successfully designed and tested a hydrogen generator utilizing a motorcycle's electrical system with configurations of 4, 8, and 12 stainless steel plates. The experimental results indicate that the addition of baking soda as an electrolyte significantly improves hydrogen production efficiency, as evidenced by faster bubble formation and measurable pressure increases on the U-tube manometer. Among the configurations, the 4-plate and 8-plate setups using 800 ml of water with 10 grams of baking soda were the most effective, showing a manometer increase of 1 ml and rapid bubble generation within 7 and 4 seconds, respectively. The decrease in voltage or current under load further

supports the occurrence of efficient electrolysis. These findings suggest that optimized plate configuration and proper electrolyte selection are crucial to enhancing the performance of hydrogen generators powered by low-voltage motorcycle systems.

## References

- [1] R. Rimbawati, C. Cholish, W. Tanjung, and M. Effendy, “Pengujian Air Bersih Menjadi Hidrogen Untuk Energi Alternatif Menggunakan Arduino,” *CIRCUIT J. Ilm. Pendidik. Tek. Elektro*, vol. 5, p. 65, Feb. 2021, doi: 10.22373/crc.v5i1.8276.
- [2] P. Pratiwi, M. Perdana, and A. Fachrurrozi, “Performance Comparison of Wet Cell HHO Generator with Galvanized Steel and Stainless Steel Electrodes,” *J. Tek. Mesin*, vol. 11, no. 2, pp. 172–178, 2021, doi: 10.21063/jtm.2021.v11.i2.172-178.
- [3] Fitriyanti, “Pengaruh Luas Permukaan Elektroda Dengan Penambahan Pwm Controller Terhadap Efisiensi Produksi Gas Hidrogen Pada Proses Elektrolisis,” *J. Sains Fis.*, vol. 1, no. 1, pp. 42–52, 2021, [Online]. Available: <http://journal.uin-alauddin.ac.id/index.php/sainfis>
- [4] H. E. G. Prasetya, J. Pratilastiarso, R. Amalia, and M. I. F., “Studi Eksperimen Suplai Generator Oxyhydrogen Menggunakan Katalis Koh,” *JTT (Jurnal Teknol. Ter.)*, vol. 5, no. 1, p. 42, 2019, doi: 10.31884/jtt.v5i1.155.
- [5] A. D. Shabahaini and M. Tamjidillah, “Pengaruh Jarak Antar Elektroda Plat Besi Terhadap Produktivitas Dan Efisiensi Generator Hho Menggunakan Metode Elektrolisis Air Laut Dengan Katalis Koh,” *Sci. J. Mech. Eng. Kinemat.*, vol. 4, no. 1, pp. 95–107, 2019, doi: 10.20527/sjmekinematika.v4i1.56.
- [6] S. S. Pangestu, G. A. Pauzi, and S. W. Suciwati, “Analisis Laju Korosi pada Sistem Energi Listrik Alternatif Berbasis Elektrolit Air Laut,” *J. Teor. dan Apl. Fis.*, vol. 6, no. 2, pp. 249–256, 2018.
- [7] Fransiskus R. K. Susanto, “Analisis Pengaruh Variasi pH Air Laut Pada Sel Volta Dua Kompartemen Dengan Elektroda Cu(Ag)-Zn Oleh,” *J. Chemurg.*, vol. 8, no. 2, p. 71, 2021.
- [8] M. Abdurahman, I. Triwahyono, and E. Suryanti, “Pengaruh Luas Permukaan Elektroda terhadap Produksi Gas Hidrogen melalui Proses Elektrolisis,” *J. Pengemb. Teknol. Inf.*, vol. 8, no. 1, pp. 45–53, 2021.
- [9] S. S. Pangestu, A. Rahman, and F. M. Setiawan, “Analisis Laju Korosi dan Efisiensi Produksi Gas HHO pada Sistem Elektrolit Air Laut dengan Penambahan Sodium Bicarbonate,” *J. Inject.*, vol. 15, no. 2, pp. 120–129, 2018.
- [10] A. Lestari, Y. Kurniasih, D. R. Indah, and Ahmadi, “Pengaruh Variasi Jumlah Elektroda Dan Jenis Katalis Terhadap Produksi Gas Hidrogen Pada Elektrolisis Air Laut,” *J. Pendidik Indones.*, vol. 5, no. 2, pp. 1–11, 2022.