

## Analysis of the Potential of Remote Monitoring and Control Systems for Energy Efficiency in Office Buildings

Roy Leo Rensius Hutauruk<sup>1</sup>, Zuraidah Tharo<sup>2</sup>, Pristisal Wibowo<sup>3</sup>

Universitas Pembangunan Panca Budi, Medan, North Sumatera, Indonesia

Article Info	ABSTRACT
<p><b>Keywords:</b> Energy Efficiency, Remote Monitoring, IoT, and Smart Control System</p>	<p>Energy consumption in office buildings represents a significant portion of operational costs and environmental impact. Efficient energy management has therefore become a critical priority. This study analyzes the potential of implementing remote monitoring and control systems to improve energy efficiency in office buildings. The system integrates Internet of Things (IoT) technologies and microcontroller-based controllers to monitor and regulate electrical loads such as lighting, air conditioning, and other office equipment. Data collection and analysis were conducted through sensor integration, cloud-based dashboards, and control algorithms. The results show that real-time energy monitoring and automated control can reduce unnecessary energy usage by up to 25%, improve responsiveness to occupancy patterns, and enable predictive maintenance. The system also supports remote access via web or mobile interfaces, allowing facility managers to make informed decisions. The findings suggest that remote monitoring and control systems offer significant potential to enhance energy efficiency, reduce operational costs, and contribute to sustainable building management practices.</p>
<p>This is an open access article under the <a href="https://creativecommons.org/licenses/by-nc/4.0/">CC BY-NC</a> license</p> 	<p><b>Corresponding Author:</b> Roy Leo Rensius Hutauruk Universitas Pembangunan Panca Budi, Medan, North Sumatera, Indonesia <a href="mailto:royrensusroy@gmail.com">royrensusroy@gmail.com</a></p>

### INTRODUCTION

Along with the development of industry and economic growth, the need for electrical energy is increasing, especially in the commercial sector such as office buildings. Office buildings are one of the significant consumers of energy because of their operational activities that run throughout the day.

Energy efficiency has become a major concern due to the high impact of energy consumption on costs and the environment. The implementation of remote monitoring and control systems based on the Internet of Things (IoT) offers great potential in energy efficiency efforts in office buildings. This system allows building managers to monitor and control energy usage in real-time, and identify areas of energy waste so that corrective actions can be taken. Through automatic monitoring and control, this system can optimize the performance of electrical devices, reduce excess energy use, and ensure that devices are used only as needed. According to data from the International Energy Agency (IEA), the commercial building sector consumes around 30% of the total global energy use, with a

significant contribution to carbon emissions. The application of sophisticated control and monitoring systems in commercial buildings, including office buildings, has been shown to reduce energy consumption by 20–30%, indicating that energy optimization through technology can have a significant impact on energy efficiency and environmental sustainability. This study aims to analyze the potential of remote monitoring and control systems in improving energy efficiency in office buildings. By using this technology, it is expected that building operational efficiency can be improved, while energy consumption and operational costs can be reduced. The results of this study are expected to provide technical recommendations for the implementation of remote monitoring and control systems in other office buildings, both in the public and private sectors, in order to achieve more efficient and sustainable energy management.

## Literature Review

### Electric Power

Power is the energy needed to do work / work. Electrical power is usually expressed in Watts. Mathematically, the amount of electrical power can be written as follows:

Where :

$$P = V \cdot I$$

$P$  is electrical power (Watts)

$V$  is voltage (volts)

$I$  is electric current (amperes)

However, in an alternating current power system where voltage and current change over time, the simple formula above becomes a little more complicated. The quantities of power, current and voltage are complex numbers and the equation above becomes:

$$S = I * V$$

where  $S$  is an apparent power and the asterisk (\*) indicates the current conjugate of the complex number  $I$ , which means that in the calculation, the sign (positive or negative) of the imaginary component of the complex number must be reversed (positive to negative and vice versa). While the actual power consumed by a load or electrical equipment is the real power ( $P$ ) expressed in watts. In mathematical form, it is formulated:

$$P = I_{rms} V_{rms} \cos \varphi$$

Where :

$P$  : apparent power/active power (Watt)

$\varphi$  : the angle formed between current and voltage.

There is another power component called reactive power, which is the power required to form a magnetic field. Symbolized by  $Q$ , expressed in Var and mathematically written as:

$$Q = I_{rms} V_{rms} \sin \varphi$$

$Q$  : reactive power (Var)

$\varphi$  : the angle formed by the current and voltage.

The relationship between apparent power, active power and reactive power can be seen through the power triangle, as shown in Figure 1.

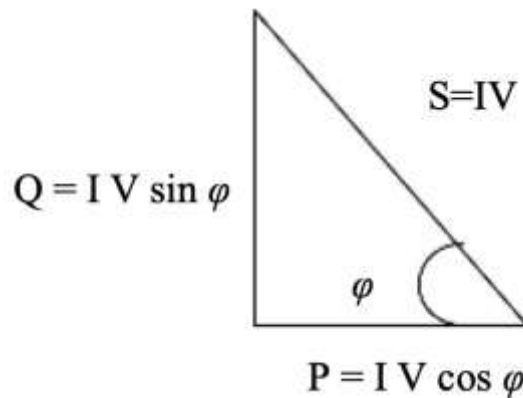

Figure 1. Triangle of Forces.

### Electric Power System

A complete electric power system contains four elements. First, the power plant. Second, transmission, complete with substations. Because of the long distance, it is necessary to use high voltage (TT), or extra high voltage (TET). Third, distribution, which usually consists of a primary distribution channel of medium voltage (TM) and a secondary distribution channel of low voltage (TR). Fourth, usage (utilization), which consists of installations for using electric power. Household installations use low voltage, while large users such as industry use medium voltage.

Electrical energy is generated in a power plant (PTL) which can be a steam power plant (PLTU), hydro power plant (PLTA), gas power plant (PLTG), diesel power plant (PLTD), or nuclear power plant (PLTN). PTL usually generates electrical energy at medium voltage (TM), which is generally between 6 and 20 KV.

In a large power system, or if the PTL is located far from the user, then the electric power needs to be transported through a transmission line, and its voltage must be increased from TM to high voltage (TT). At very long distances, extra high voltage (TET) is even needed. Increasing the voltage is done at the substation (GI) using a step-up transformer.

Approaching the center of electricity consumption, which can be an industry or a city, the high voltage is lowered to medium voltage (TM). This is also done in a GI by using a step down transformer. In Indonesia, the medium voltage is 20 KV. This 20 KV line runs through the streets throughout the city, and is the primary distribution system.

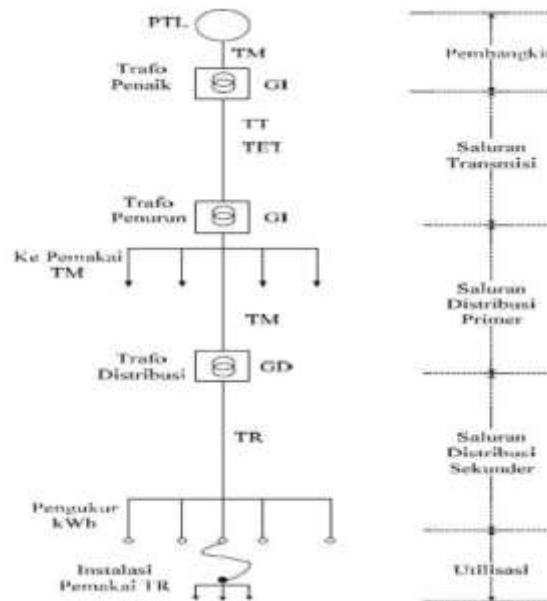

**Figure 2.** Electric Power System

Low voltage power distribution network is the downstream part of an electric power system, on the sides of the road, usually close to intersections there are distribution substations (GD). Which converts medium voltage to low voltage through distribution transformers. Through the electric poles visible on the side of the road, low voltage electricity is distributed to consumers. In Indonesia, low voltage is 220/380 volts, and is a secondary distribution system, called a low voltage network (JTR). The Low Voltage Network is the distribution of electricity starting from the secondary side of the distribution transformer which covers all parts of the network and its equipment, up to the load Measuring and Limiting Device (APP).

The amount of current flowing along the conductor is not the same, because the house connection point (SR) at each TR pole is different. The amount of current at the first pole is greater than the current at the second pole, and so on gets smaller until the end pole. Voltage drop is the voltage sent is not the same as the voltage received by the load, because the current ( $I$ ) flowing along the conductor is directly proportional to the resistance ( $R$ ), while the amount of power loss along the network is the square of the current ( $I^2$ ) multiplied by the resistance of the network conductor ( $R$ ). Because the magnitude of the load current varies in each phase R, S, T throughout the network, causing the loading on the secondary transformer is an unbalanced load, the neutral current will flow to the earth through the grounding conductor. then it is difficult to calculate the overall power losses of the conductor. this study uses several assumptions and the calculation results obtained are not the actual results but are the results of the approach.

### Smart Energy Control System

The system is a collection of components (hardware and software) that work together and are integrated to achieve a goal. A system that can be controlled dynamically is called an intelligent system (Smart). So it can be said that the Smart Energy Control System is an

energy control system that is able to work dynamically. Energy Management Energy management is an activity in a company that is organized using management principles, with the aim of carrying out energy conservation, so that energy costs as one component of production/operation costs can be reduced as low as possible. Energy conservation itself means an effort to continue to use energy rationally but still maintain productivity and meet the requirements of corporate governance. Rational energy use includes energy savings and efficiency. So it must be distinguished between energy savings and energy conservation. Energy saving can be done by simply reducing energy usage but comfort and productivity are reduced. While energy conservation is the application of principles in energy management not only reducing energy usage but also implementing efficient operating patterns, installing additional equipment that improves system performance so that energy usage is lower but does not reduce comfort and productivity. So in essence energy conservation is a guide on how to save energy properly and contains methods and tools that can be used to save energy without reducing productivity and comfort. While energy efficiency means the comparison between energy usage and production results. What is meant by production can be comfort, movement and others.

So high energy efficiency means low energy consumption but high production. Thus the concept of energy conservation is broader than energy efficiency. Energy management in general can be defined as management that has a direct impact on the organization, techniques and economical actions in order to minimize energy consumption, including energy for production/activities and to minimize the consumption of raw materials and other additional materials. Thus energy management is a structured activity towards energy with the aim of continuously reducing energy consumption and maintaining the improvements that have been achieved.

### **Internet Of Things**

The new paradigm in global network technology is the Internet Industry also known as the Internet of Things (IoT). Future technology that is the most important focus in various industrial fields is the implementation of IoT to facilitate the implementation of organizational operations. Every part, machine and device that exists is connected through this network and works together (lee and lee, 2015). The IoT concept provides broader benefits for devices that are continuously connected to the internet network, for example electronic devices or other objects that are equipped with sensors and are prepared to always be actively connected widely, both locally and globally (Panduardi and Haq, 2016). Internet of Things is an idea that aims to expand the function of continuously connected internet connectivity. The uses include data sharing, remote control, and so on, including objects in the real world. The application of IoT in the real world can be used to monitor or control various aspects of food, electronics, collections, any equipment, including living things that are all connected to local and global networks through embedded sensors that are always active. IoT has developed rapidly starting from the integration of wireless technology, MicroElectromechanical Systems (MEMS) and also the Internet. IoT uses several technologies that are broadly combined into one unit including sensors as data readers, internet connections with several types of network topologies, Radio Frequency

Identification (RFID), wireless sensor networks and technologies that will continue to grow according to needs (C. Wang et al., 2013). IoT can also include other sensor technologies, such as wireless technology or QR codes that we often find around us, examples of its application in objects in the real world are for food processing, electronics, and various other machines or technologies that are all connected to local or global networks via embedded sensors and are always on. This IoT refers to machines or tools that can be identified as virtual representations in their Internet-based structures.



**Figure 3.** ESP8266, One of the popular microcontrollers for IoT

The biggest challenge that can be an obstacle in configuring IoT is bridging the gap between the physical world and the information world and how to build its communication network, because the network required by IoT is very complex. In addition, IoT also requires a fairly tight security system. In addition to these problems, the expensive cost of developing IoT is also often a factor causing failure, so that its creation and development can end in production failure.

How IoT works, by utilizing a programming argument, where each argument command can produce an interaction between machines that have been connected automatically without human intervention and without being limited by long distances. The internet is the link between the two machine interactions. Humans in IoT only act as regulators and supervisors of the machines that work directly.

### Sensor

A sensor is a component used to detect changes that occur in an object or environment, either physical or chemical changes, and convert physical or chemical quantities into electrical quantities. Manufacturing technology, sensor structure, and signal processing algorithms are factors that affect the quality of a sensor's performance. There are many types of sensors that can be used to detect changes according to the condition of the object to be detected, such as pressure sensors, light, pressure, sound, temperature, encoders, flame sensors and others.

The key common to all sensors is conversion: the sensor, (or "detector"), detects and measures physical objects or quantities, which can be as varied as an electronic identification code on a specially designed tag known as an RFID chip, (where RFID stands for Radio Frequency Identification), the quantity of heat in an object, fluid or person, the movement of an object, person or animal into an electronically monitored field of vision, or

the type of acceleration an object experiences, such as free-fall or rotation. After measurement, the sensor converts the data it has received into a signal or visual display that can then be meaningfully interpreted by either a human agent or by another electronic device. A sensor, in other words, is also always a transducer - a device that converts one form of energy or stimulus into another.



**Figure 4.** Example of Temperature Sensor (Left) and Flame Sensor (Right)

One form of motion sensor, for example, can be integrated into an industrial machine and wired to a safety switch. This allows a safe shutdown if in the event of a signal detector to the switch aberrant mechanical movement that could damage the equipment, since if continued it would pose a danger to nearby humans. This is an example of a measurement being converted into a signal for input to a non-human device, but of course many sensors convert measurements into scales or displays intended for measurement by the human eye.

The mercury-in-glass thermometer, for example, is a ubiquitous form of temperature sensor that converts the expansion or contraction of a small bulb of mercury into a readable scale (Celsius or Fahrenheit): as the mercury expands or contracts, it rises or falls inside a narrow hollow filament in the glass, which has a calibrated temperature scale inscribed on the outside surface of the thermometer. Still regarding the mercury contained in the thermometer glass, in the temperature range it is designed to measure, it displays an important feature required of all sensors: linearity. In other words, the physical changes in the detector material of the sensor, in this case mercury, are in direct proportion to the changes in the object, force, motion or radiation under measurement. Another type of sensor, the thermocouple, will similarly respond linearly to changes in temperature, in this case producing a change in output voltage that is proportional to the change in heat. To ensure accuracy, sensors are carefully calibrated to conform to established, tried and tested scales.

In the electronic civilization, sensors play a vital role in ensuring the functioning of a large number of machines, gadgets, vehicles and manufacturing processes. Most people may be completely unaware that sensors are behind many of the things they take for granted, such as the accelerometer, which ensures the screen on your phone or tablet is always the right way up until any movement or rotation of the device is experienced, or the sensors that help cars and airplanes function safely. Sensors are widely used in medical devices, aerospace engineering, in manufacturing automation and robotics, and several

other applications. The sensitivity of the sensor determines many applications of the sensor itself. When the sensor responds to relatively large changes in a medium with relatively small changes in the material detector and the consequent output, it shows low sensitivity. But sometimes a sensor is required to measure small changes, in which case the sensor is required to show high sensitivity, responding significantly to minute changes in the medium under measurement. Often, the linearity of such sensors is limited to a strictly defined range, beyond which it will respond inaccurately.

## METHOD

The system will first initialize other electronic components. Such as checking the relationship between the RTC carried out by the Arduino Nano. If in this process there is a problem with one of the components, then the system is considered defective (not working effectively). If the system continues to work in this condition, it is feared that the system will provide decisions/outputs that are not in accordance with expectations. For example, if during the day (operating hours/electricity flowing to the load) the system is turned on but the RTC battery runs out, it will reset the time on RTC. If this time is used as a decision-making variable, then during the daytime (operation) hours, the load will not be supplied with electricity because the system will get the time from the RTC at 00.00 or idle time. Then the system will read the data set of operating hours and idle time. This data is stored by wemos and will be read by Arduino nano. The subroutine starts in the next process, which is reading data from the energy meter. The data will be displayed on the LCD and Website monitoring. The system will read the current time and then check whether the current time has entered idle time. If the current time has entered idle time and the system is set automatically, then turn off the flow of electrical energy to the load. Then the system will perform a subroutine or loop, which is to return to the step of reading the energy meter data. The system can be set with automatic or non-automatic settings. In automatic settings, the system will disconnect the flow of electrical energy to the load during idle time. In non-automatic settings, the system will not disconnect electricity to the load during idle time. This non-automatic setting is useful when collecting data on electrical load usage during idle time.

In SiSCE, Arduino nano is an important component in the system to run properly. Arduino nano is a microcontroller that functions to read, evaluate, and send data both on the relay output (for circuit breakers) voltage/current) and on Wemos (reading data on the energy meter module and RTC).

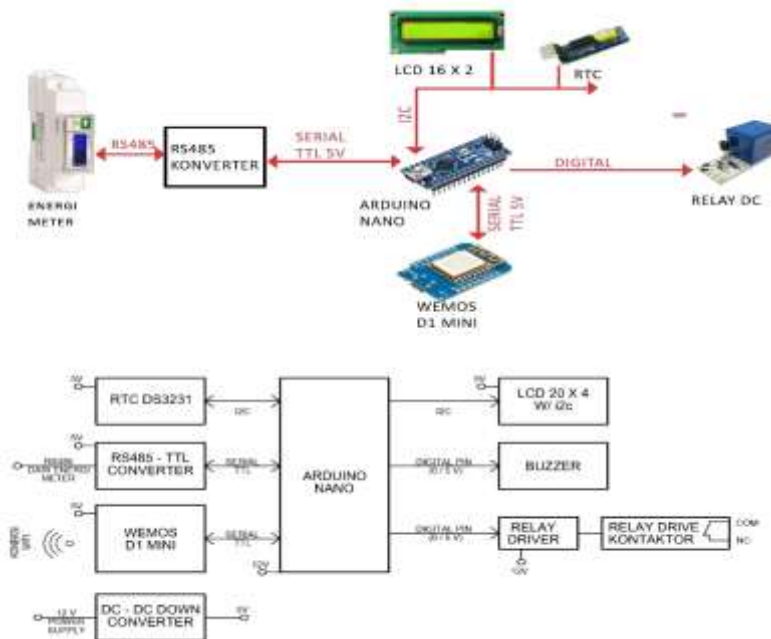

**Figure 5.** Arduino Nano data communication scheme

Arduino Nano has various data communication protocols, where the protocols are used by the modules connected to it. Each module has a different type of communication protocol, such as relays that only requires digital output compared to LCD and RTC which require I2C serial communication. In the energy meter, the protocol used is RS485, where Arduino Nano does not have this protocol in general, therefore a signal converter is needed so that the energy meter can communicate with Arduino Nano. The SiSCE system uses electrical energy from the PSU (Power Supply Unit) which consists of a 12 V DC Power Supply and a DC – DC Converter. The 12 V power supply comes from the PLN electric current (which will be distributed through the MCB), where this voltage will be used to activate the relay and system, but because the Arduino Nano and Wemos D1 Mini use a voltage of 5 V, the 12 V from the power supply will be lowered first using a DC-DC converter, then will be distributed to the system. The relay will be connected to the contactor so that it can flow a larger current

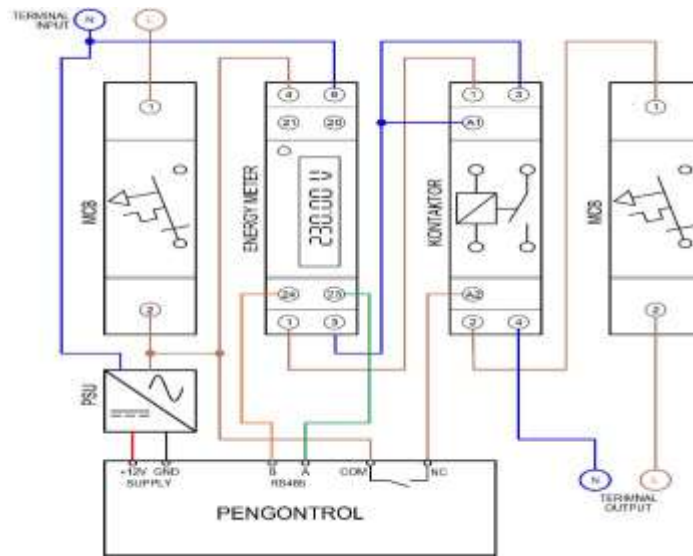

Figure 6. System wiring diagram

## RESULT

### Working and Testing Procedures

Testing the assembled tool prototype is needed to determine the functionality and performance of the tool. In this study, the SiSCE prototype was made according to the predetermined planning and schematic and will go through a testing stage before taking data that is considered valid. Testing functions to determine whether the tool is working according to the expected performance and to ensure that all components work properly during valid data collection. The parts that will be tested on this tool are from the software and hardware parts, where the software includes sending and receiving data and data processing, and the hardware includes calibration of tool readings and the physical condition of the tool components (such as test relays and contactors), web testing will also be carried out for monitoring functions. After testing is completed with good results, data collection will be carried out at the PT Eviza Jaya Medica office building during operational time and idle time, the data that will be taken is valid data that will be processed to obtain energy savings results from using this tool.

The working procedure for installing SiSCE is as follows:

1. All loads from the building must be disconnected first by turning off the MCB/MCCB on the electrical panel.
2. The SiSCE panel is installed and its power is connected to 220V directly from the PLN terminal via the MCB controller. Connect all loads to the controller output (220V output will go through 1 contactor and 1 additional MCB)
3. Turn on the output MCB switch, then turn on the controller MCB switch. SiSCE will turn on and will turn on the contactor according to the selected program, then the current load will run normally again.

Meanwhile, testing of individual SiSCE components is as follows:

1. Component testing is carried out with an empty load, except when checking the energy meter.
2. The LCD and RTC are tested simultaneously by viewing the output on the screen and determining the accuracy of the time reading on the RTC module.
3. DC relays and contactors are tested by turning on their contacts and measuring the continuity of their output using a multimeter.
4. Arduino Nano is tested by detecting data readings from other components such as RTC and energimeter.
5. WEMOS D1 is tested by viewing data transfer from the webserver.
6. The energy meter is tested by applying a load to the SiSCE and observing RS 485 data reception on the converter in Arduino Nano.

### Component Testing

The SiSCE prototype tool was assembled and tested. Researchers grouped the testing of this tool into hardware and software testing. For contactors and relays, testing can be done using only a multimeter, but for some other hardware such as LCD, energy meter, RTC module, software is needed to find out whether the components are running properly or not. After the hardware testing is complete, software testing will be carried out which includes testing the sending and receiving of data on the microcontroller used (Arduino Nano and Wemos D1 Mini), then data transmission to the internet (webserver) will be carried out and the data value will be checked on the server using a browser. Below are the results of the SiSCE prototype assembly:



**Figure 7.** Overall Tool (SiSCE control panel)

RTC plays an important role in SiSCE, because basically the microcontroller cannot know the real-time time without an external clock module. In this system, time is a very vital variable because it is the only variable that determines the operating conditions of the system. Before use, the RTC must also be set first according to the existing real-time time, then using the internal battery in the RTC module, this module switches functions as a clock, this is what causes even though the system is turned off, the time on the RTC continues to run.

Similar to the LCD module, the RTC module is connected to the Arduino Nano via I2C communication. Because it uses an internal battery, if the internal battery is problematic, the RTC will issue a default time variable (not in accordance with the actual time), therefore SiSCE is equipped with an RTC condition checking feature, because time reading errors can have a negative impact on the time accuracy of SiSCE (for example, the actual clock is still in operational time, but due to an RTC error, the system reads the time at idle time, so that the entire load is disconnected during operational time). System errors in determining conditions can cause losses to users. Testing the RTC module is by reading the time given by the module using Arduino Nano, then the time is compared with the real-time time whether it is appropriate or not. If the time is not appropriate, then an adjustment will be made to the RTC module. This process is carried out 3 times within a period of 3 days randomly to obtain constant and accurate results. If within 3 days the time is not appropriate (repeated settings are required), then it can be stated that the internal battery component or the RTC module itself is damaged and needs to be replaced. The results of testing the RTC module on SiSCE are as follows:

**Table 1.** RTC Module Testing

Date	Time		
	Real Time	RTC Time	Tuning
December 12, 2020	13:06	00:00	Done
December 13, 2020	11:35	11:35	Are not done
December 14, 2020	12:14	12:14	Are not done
December 15, 2020	08:44	08:44	Are not done
December 16, 2020	20:09	20:09	Are not done



**Figure 8.** RTC Module Testing

From the test results, it can be seen that at the beginning of the test the RTC module did not show the correct time, this could be because the RTC module had not been set from the factory default. However, after the adjustment, it can be seen that the time reading is constant (the same) as the real-time time for several days, so it can be concluded that the RTC module is working properly.

## Energy Meter Testing

Although the energy meter does not determine the output of the current flow to the load, the variables of the energy meter are equally important to monitor the electricity consumption being used by the load. This is also because one of the main features of SiSCE is being able to see the electric current and electric energy used in real-time, so the energy meter is one of the vital components in SiSCE. The energy meter works by connecting the load in series with the module. The energy meter will read the current and voltage used by the load, and will use the data to calculate the power used. The energy meter will also record power usage in units of time so that the energy meter can show the value of electrical energy (kWh). One of the features of the energy meter is that the data recorded by the energy meter can be transmitted, so that the microcontroller (in this case the Arduino Nano) can read the data processed by the energy meter. Because the energy meter has a MODBUS data interface with an RS-485 connector, a converter is needed before the signal from the energy meter enters the Arduino Nano (this microcontroller does not support the MODBUS signal interface). Therefore, the signal from the energy meter must first be converted into a serial signal, so that it can be read by the microcontroller. The same thing also applies vice versa, the serial request signal from the microcontroller must first be converted into a MODBUS signal with the same converter, so that the signal from the microcontroller can be read properly by the energy meter. MODBUS stores data in registers and can be accessed by read or write (citation). In the case of this energy meter, each manufacturer provides address information (or command code) to access or change data in the device. Testing is done by sending commands in serial form using Arduino Nano. If communication is running well and the module is working properly, the energy meter will resend a signal response in the form of data requested by Arduino Nano.

By accessing the function and address of the energy meter, the energy meter reading value can be read by the Arduino. The energy meter is connected to the load directly for testing (testing is done at home). The data read on the Arduino is as follows:

**Table 2.** Energy Meter Test Results

Address (Address)	Reading Value (Hexadecimal, Float32)	Mark	Decimal	Unit
0x0BB8	40 0D 70 A4	2,210		A
0x0BD4	43 5D 00 00	221		V
0x0BEE	43 F3 19 9A	486.2		kW
0x0C0C	3F 5E B8 52	0.87		-
0x0C26	42 48 00 00	50		Hz

The energy meter will send data to the Arduino with a byte array data type. This data has information from the parameters requested by the Arduino via the MODBUS communication line. This data is still raw, so it must be converted again on the microcontroller to display data that is easier for the user to understand, namely by converting the byte array into a decimal value (float or double), where this data will be displayed on the LCD display and sent to Wemos D1. From the data reading results, it can be seen that the energy meter can work and communicate well with the system.

### Relay and Contactor Testing

To regulate the flow of electricity to the load, this tool uses a combination of relays and contactors. Testing is done by entering an ON signal from the system's digital pin to the relay and contactor that have been connected to the circuit, then measuring its continuity using a multimeter. From the image above, it can be seen that the output from the contactor is connected when the relay is turned on, and the terminals are also connected, so it can be concluded that the relay and contactor in this system are working properly.



**Figure 9.** Energy Meter Testing

After testing and installation of SiSCE devices in office buildings, the actual data can be recorded. In this data collection used manual mode of the tool so that the contactor will not disconnect the power even though the condition is in idle time, this functions to measure the electrical energy used during idle time so that the potential electricity savings can be calculated by using this tool. Data collection was carried out for 11 days, namely from February 15 to February 26, 2021 with office activity conditions as usual. The results of measuring electricity usage in the Eviza Jaya Medica building for 11 days are as follows:

**Table 3.** Electricity Usage Data During Operational Time and Idle

Day	NoUsage	Date	Usage (Wh)		Burden
			O'clock	Idle Time	
			Operational (18.00 - 7.30)	(7.30 - 17.59)	
Tuesday	1	15 (Operation), 15-16 (Idle)	864	4120	10 Computer
Wednesday	2	16 (Operation), 16-17 (Idle)	0	4180	10 Computer
Thursday	3	17 (Operation), 17-18 (Idle), 18 (Operation), 18-19	2520	4200	10 Computer

Friday	4	4530	4140
	(Idle)		Computer

The peak electricity usage during operating hours was obtained on the 4th and 9th days (both on Friday) with electricity usage of 4530 and 4510 Wh respectively. The use of idle time from the first to the last day of the trial period produced a value that did not change much with a median of around 4163.3 Wh per day, where Saturday and Sunday were not counted because they were holidays. The total electricity consumption during idle time for 11 days in the Eviza Jaya Medica building is 37,470 Wh. From the data obtained, financial losses can be calculated based on the building's basic electricity tariff of Rp. 1100/kWh (B-1 1301-5500 VA) with the following results:

Total idle time usage = 37470 Wh.

Time = 11 days

per day = 3406.36 Wh/day

per month = 102190 Wh/month

per month = 102,190 kWh/month

Loss per month = 102,190 kWh/month × Rp 1100/kWh

Loss per month = Rp. 112410 / month

From the calculation above, it can be seen that there is a loss of Rp. 112410 that must be paid every month with an idle time load of 10 computers, each computer uses an average of around 135 Watts of power. So that daily usage:

$$= (135 \text{ Watts} / 1,000) \times (10 \text{ hours} + (30 \text{ minutes} / 60))$$

$$= 0.135 \text{ kWh} \times 10.5 \text{ hours}$$

$$= 1.4175 \text{ kWh per day}$$

From the data collected, the total electricity usage during idle time is very high when compared to usage during operations. The results of this study illustrate that the use of electrical energy during idle time almost 50% compared to operating hours. By using SiSCE can save electricity by 50% or save money financial of Rp. 112410 per month, this is done by deciding electrical energy automatically during idle time.

## CONCLUSION

The results of this study demonstrate that the implementation of remote monitoring and control systems can significantly improve energy efficiency in office buildings. By leveraging IoT-based technology, microcontrollers, and cloud platforms, the system enables real-time monitoring, automated control, and data-driven decision-making. The integration of sensors and smart control algorithms allows for the optimization of electrical loads such as lighting, HVAC, and office appliances, leading to a measurable reduction in energy consumption of up to 25%. Moreover, the ability to remotely access system performance through web and mobile interfaces enhances operational convenience and supports proactive maintenance strategies. This contributes not only to reduced operational costs but also to more sustainable and intelligent energy use in modern office environments. Therefore, remote monitoring and control systems present a viable solution for facility managers seeking to

enhance energy management, improve system responsiveness, and support environmentally responsible building operations.

## REFERENCES

- Alamsyah, A., Amir, A., & Faisal, M. N. (2015). Perancangan dan Penerapan Sistem Kontrol Peralatan Elektronik Jarak Jauh Berbasis Web. *Jurnal Mekanikal*, 6(2), 577-584.
- Aryza, S., Irwanto, M., Lubis, Z., Siahaan, A. P. U., Rahim, R., & Furqan, M. (2018). A Novelty Design Of Minimization Of Electrical Losses In A Vector Controlled Induction Machine Drive. In *IOP Conference Series: Materials Science and Engineering* (Vol. 300, No. 1, p. 012067). IOP Publishing.
- Hamdani, H., Tharo, Z., & Anisah, S. (2019, May). Perbandingan Performansi Pembangkit Listrik Tenaga Surya Antara Daerah Pegunungan Dengan Daerah Pesisir. In *Seminar Nasional Teknik (Semnastek) Uisu* (Vol. 2, No. 1, pp. 190-195).
- Khan, I., Belqasmi, F., Glitho, R., Crespi, N., Morrow, M., & Polakos, P. (2016). Wireless sensor network virtualization: A survey. *IEEE Communications Surveys & Tutorials*, 18(1), 553-576.
- Lee, I., & Lee, K. (2015). The Internet of Things (IoT): Applications, investments, and challenges for enterprises. *Business Horizons*, 58(4), 431-440.
- Putri, M., Wibowo, P., Aryza, S., & Utama Siahaan, A. P. Rusiadi. (2018). An implementation of a filter design passive Ic in reduce a current harmonisa. *International Journal of Civil Engineering and Technology*, 9(7), 867-873.
- Panduardi, F., & Haq, E. S. (2016). Wireless Smart Home System Menggunakan Raspberry Pi Berbasis Android. *Jurnal Teknologi Informasi dan Terapan*, 3(1).
- Syam, Rafiuddin. (2013). *Dasar Dasar Teknik Sensor: Untuk Beberapa Kasus Sederhana. Seri Buku Ajar*. Universitas Hassanuddin. Kota Makassar
- Tarigan, A. D., & Pulungan, R. (2018). Pengaruh Pemakaian Beban Tidak Seimbang Terhadap Umur Peralatan Listrik. *RELE (Rekayasa Elektrikal dan Energi): Jurnal Teknik Elektro*, 1(1), 10-15.
- Wang, C., Daneshmand, M., Dohler, M., Mao, X., Hu, R. Q., & Wang, H. (2013). Guest Editorial - Special issue on internet of things (IoT): Architecture, protocols and services. *IEEE Sensors Journal*, 13 (10), 3505–3508.  
<http://doi.org/10.1109/JSEN.2013.2274906>
- Purnomo, Arif Eko. 2019. *Pengukur Kecepatan Angin Jarak Jauh Menggunakan NodeMCU ESP 8266*. Sekolah Tinggi Manajemen Informatika Dan Komputer AKAKOM. Kota Yogyakarta
- Tharo, Z., Syahputra, E., & Mulyadi, R. (2022). Analysis of Saving Electrical Load Costs With a Hybrid Source of PLN-PLTS 500 Wp. *Journal of Applied Engineering and Technological Science (JAETS)*, 4(1), 235-243.
- Tharo, Z., Sutejo, E., & SK, G. M. (2024). Harnessing Solar Energy for Sustainable Urban Street Lighting. *Asian Journal of Environmental Research*, 1(2), 107-115.
- Wibowo P et al (2024) A Development Of Charging System For Electric Vehicles. *Jurnal Scientia*, 13(04), 1461-1468.