

# Design and Implementation of an IoT-Based Automatic Irrigation and Environmental Monitoring System for *Amorphophallus muelleri* (Porang) Cultivation

Resky Harsuni, Ida Laila, Bualkar Abdullah, Arifin Arifin\*

*Department of Physics, Faculty of Mathematics and Natural Science, University of Hasanuddin, Makassar, 90245, Indonesia*

(Received October 09, 2025; revised February 03, 2026; accepted February 07, 2026; published online April 18, 2026)

The cultivation of *Amorphophallus muelleri* (porang) in Indonesia is highly dependent on rainfall patterns and is influenced by environmental factors such as temperature, soil moisture, light intensity, and precipitation. This dependency often results in inefficient irrigation management and suboptimal plant growth. This study aims to develop an Internet of Things (IoT)-based automatic irrigation and environmental monitoring system specifically designed to support porang cultivation and improve water management efficiency. The system was implemented using an Arduino Uno microcontroller and a NodeMCU ESP8266, integrated with DHT22 (temperature and humidity), YL-69 (soil moisture), BH1750 (light intensity), and rain sensors, and connected to the Blynk IoT platform for real-time monitoring and remote control. Calibration results showed low measurement errors of 2.19%, 1.75%, and 5.09% for the temperature, soil moisture, and light intensity sensors, indicating reliable sensor performance. The test results showed that the system was able to automatically activate the water pump when soil moisture fell below the 50% threshold, thereby maintaining soil moisture within the optimal range under various environmental conditions. Overall, the proposed system enables continuous environmental monitoring and effective automatic irrigation control to support optimal porang growth.

**Keywords:** *Automatic Irrigation, Internet of Things, Porang Cultivation, Smart Farming, Soil Moisture Control*



This is an open access article under the [CC BY-NC](https://creativecommons.org/licenses/by-nc/4.0/) license.  
Copyright © 2026 by Author. Published by Physical Society of Indonesia

## 1. INTRODUCTION

The advancement of science and technology has significantly influenced various aspects of human life, including the agricultural sector. As an agrarian nation, Indonesia relies heavily on agriculture as a primary source of livelihood for much of its population. However, agricultural activities in Indonesia remain highly dependent on the rainy season, which often results in suboptimal crop yields (Sintia et al., 2018). This dependency on rainfall becomes particularly critical in porang cultivation, which requires stable and specific environmental conditions to support optimal tuber growth.

Achieving high-quality harvests requires a well-structured and efficiently managed production system, particularly in terms of timely and accurate irrigation tailored to the specific needs of each crop (Irsyam et al., 2019). Irrigation is defined as the process of supplying water to agricultural land through systematic and predetermined methods. In practice, however, irrigation is often conducted irregularly due to several challenges, including limited labor availability, unpredictable weather patterns, and the absence of reliable monitoring systems (Zulfikar, 2018).

The porang plant (*Amorphophallus muelleri* Blume) is a tuber-producing crop widely cultivated in tropical and subtropical regions (Rahayuningsih et al., 2020). Successful cultivation of porang requires specific environmental conditions, including a light intensity ranging from 3,000 to 10,000 lux (approximately 40%), temperatures ranging from 25°C to 35°C, rainfall between 300 mm/month and 500 mm/month, and soil moisture levels ranging from 50% to 60% (Sari & Suhartati, 2015).

\*Contact Author: [arifinpide@gmail.com](mailto:arifinpide@gmail.com)

Smart farming represents a modern agricultural paradigm that integrates advanced technologies to enhance the efficiency, sustainability, and productivity of farming practices. Among the technologies most widely adopted in smart farming is the Internet of Things (IoT), which facilitates automation of agricultural operations, real-time environmental monitoring, and intelligent control of various farm functions (Hidayat, 2017).

Recent research has increasingly explored the application of IoT-based irrigation systems to improve water management efficiency and real-time environmental monitoring. For example, an automated smart irrigation system based on IoT has been shown to maintain soil moisture within optimal ranges under varying field conditions, demonstrating significant improvements in irrigation effectiveness (Liu et al., 2025). Another study highlighted the integration of low-power wide-area networks such as LoRa with IoT sensors to extend communication range and enable remote irrigation control in large agricultural areas (Gupta et al., 2025). In addition, cloud-based IoT irrigation systems have been developed that facilitate scalable data analytics and remote decision support for farm management (Morchid et al., 2024). Such advancements illustrate the increasing relevance and adaptability of IoT technologies in precision irrigation and smart farming.

In addition to these recent developments, several previous studies have introduced IoT-based systems for automatic irrigation control and environmental monitoring. Munir et al. (2019) developed a smart farming framework capable of real-time environmental data acquisition and automatic irrigation based on sensor feedback. Their system employed Arduino Uno and ESP8266 microcontrollers, with data visualised through a Smart Watering System (SWS) application integrated with fuzzy logic and blockchain technology (Munir et al., 2019). Similarly, Krishnan et al. (2020) proposed a remote irrigation system integrating soil moisture, temperature, and rainfall sensors, equipped with an automatic pump controller and a notification interface via LCD and short message service (SMS) (Krishnan et al., 2020). Ariffin and Zin (2021) also designed an IoT-based irrigation and monitoring system for chilli (*Capsicum annuum*) plants using NodeMCU ESP8266 and the Blynk platform to monitor soil pH and moisture while controlling water flow remotely.

Additionally, Reghukumar and Vijayakumar (2019) developed an IoT-enabled irrigation framework displaying temperature and moisture data via the ThingSpeak application with integrated email notifications (Reghukumar & Vijayakumar, 2019). Although numerous IoT-based irrigation and environmental monitoring systems have been developed, most existing studies primarily focus on a limited number of parameters, such as soil moisture or temperature, and are frequently evaluated under laboratory-scale or short-term experimental conditions. Consequently, their applicability to real agricultural environments with dynamic and complex field conditions remains limited. Furthermore, only a few studies specifically address irrigation management for *Amorphophallus muelleri* cultivation, which requires stable and well-controlled environmental parameters to ensure optimal tuber development. Therefore, there remains a need for a comprehensive and field-deployable IoT-based system capable of integrating multiple environmental sensors with automatic irrigation control tailored to the specific requirements of porang cultivation. This study, therefore, proposes the design and implementation of an integrated IoT-based automatic irrigation and environmental monitoring system and evaluates its performance under actual cultivation conditions.

Building upon these previous works, this research aims to develop an automatic irrigation and environmental monitoring system specifically designed for *Amorphophallus muelleri* cultivation. The system integrates temperature, soil moisture, light intensity, and rainfall parameters, and is controlled through a water pump connected to the Blynk IoT platform, enabling continuous online monitoring and remote irrigation control.

## 2. METHOD

This research was conducted through several methodological stages, beginning with a literature review to establish the theoretical foundation and research framework. Subsequent stages included the design and development of both hardware and software components, sensor calibration to ensure accurate environmental data acquisition, and system testing to evaluate overall performance. When discrepancies were identified during testing, appropriate modifications and retesting were performed.

The final stage involved field data collection from the porang cultivation site and subsequent data analysis to assess the effectiveness of the developed system. The stages of the research methodology are illustrated in Figure 1.

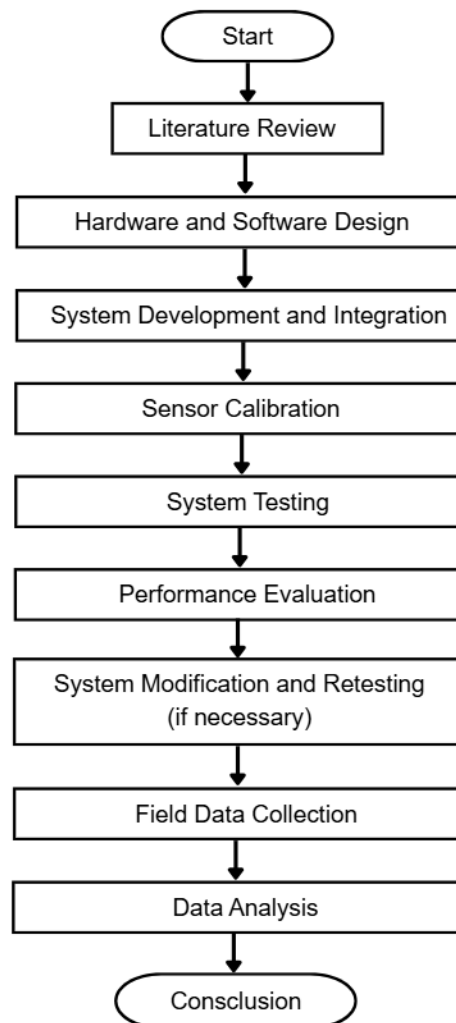

**Figure 1** Flowchart illustrating the stages of the research methodology

## 2.1 Design Hardware

The hardware for the automatic irrigation and environmental monitoring system was designed as illustrated in Figure 2. The system consists of several sensors: a YL-69 soil moisture sensor, a DHT22 temperature and humidity sensor, a BH1750 light intensity sensor, and a rain gauge sensor. These sensors were employed to detect and record the environmental conditions surrounding the porang plants.

Sensor data were processed by an Arduino Uno microcontroller and subsequently transmitted to a NodeMCU ESP8266 Wi-Fi module. The NodeMCU sent the data to the Blynk cloud platform, allowing real-time monitoring of sensor readings via the Blynk mobile application.

A relay module was used as an automatic switch to control the irrigation pump. The pump activated automatically when the soil moisture level fell below the 50% threshold. A laptop was utilised for programming and configuring the system using the Arduino IDE. The overall circuit was constructed to enable efficient and remote irrigation and environmental monitoring for porang cultivation.

## 2.2 Design Software

The software design involved the process of communication and data management from the sensors to the monitoring interface. Environmental parameters measured by the sensors, including

temperature, soil moisture, light intensity, and rainfall, were first processed by the Arduino Uno and transmitted to the NodeMCU ESP8266 via serial communication.

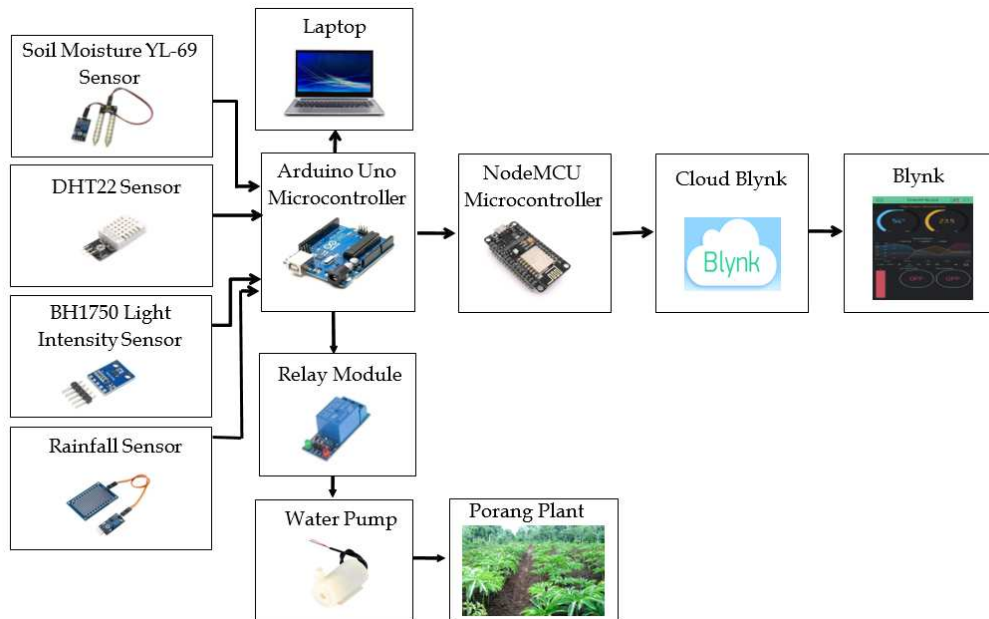

**Figure 2** Hardware design of the irrigation and monitoring system for porang plants.

The NodeMCU served as a Wi-Fi module that connected the device to the Blynk cloud through the internet. Programming was conducted using the Arduino IDE, which incorporated the authentication token (auth token) from the user’s Blynk account as a unique device identifier. The SSID and password of the Wi-Fi network were entered to enable connectivity. Sensor data were acquired and transmitted to the Blynk cloud platform at 1-minute intervals to support real-time monitoring and automatic irrigation control.

Once connected, data from each sensor was periodically transmitted to the Blynk server and displayed in real time on the Blynk Console dashboard, which is accessible via both web and mobile applications. The “online” indicator on the Blynk Console confirmed that the device was successfully connected and functioning as expected.

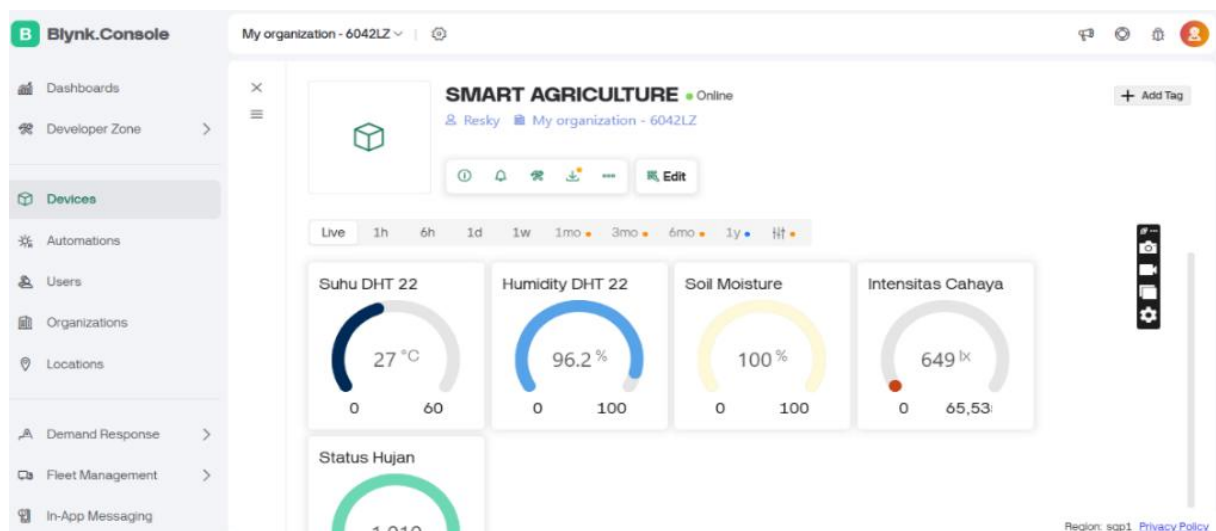

**Figure 3** Display of the Blynk Console dashboard.

### 2.3 System Testing

The system testing phase was performed following the completion of all hardware assembly, software programming, and sensor calibration. The system, comprising DHT22 (temperature and humidity), YL-69 (soil moisture), BH1750 (light intensity), and a rain sensor, was connected to the Arduino Uno microcontroller. All sensor data were transmitted through the NodeMCU ESP8266 to the Blynk application for real-time monitoring.

The software was developed in the Arduino IDE environment, integrating Blynk authentication and Wi-Fi network configuration. A relay module was incorporated to automatically control the water pump based on soil moisture readings. When soil moisture dropped below 50%, the pump was automatically activated.

Testing was carried out to verify the functionality of all system components, including sensor response accuracy, data transmission reliability, and the automatic irrigation process. Following successful laboratory trials, the system was deployed in the porang cultivation field to collect real-world performance data for evaluation under actual environmental conditions.

## 3. RESULTS AND DISCUSSION

### 3.1 Results of Instrumentation Design

The system design integrated several key components, including a YL-69 soil moisture sensor, a DHT22 temperature and humidity sensor, a BH1750 light intensity sensor, and a rain gauge sensor. These sensors were connected to an Arduino Uno microcontroller, which functioned as the main data processing unit. For wireless data transmission, a NodeMCU ESP8266 Wi-Fi module was employed to send sensor data to the Blynk cloud platform, thereby enabling real-time monitoring through the Blynk mobile application. Compared with previously reported IoT-based irrigation systems, the instrumentation design developed in this study demonstrates several advantages in terms of both architecture and functionality.

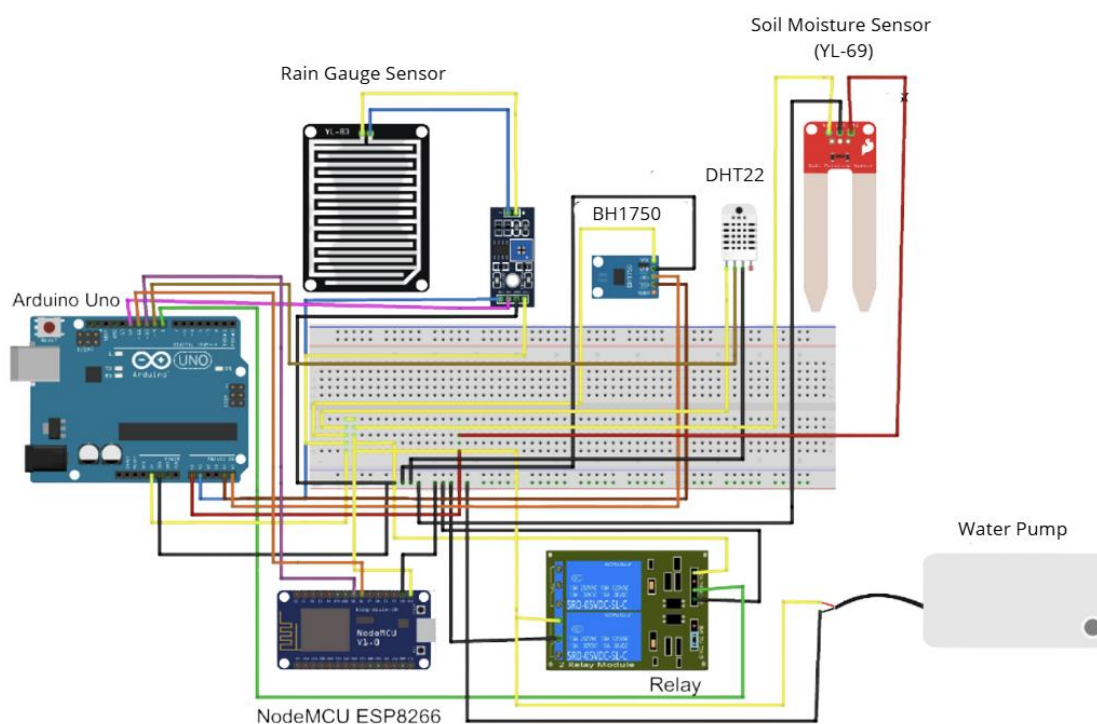

**Figure 4** Circuit design of the IoT-based automatic irrigation and environmental monitoring system.

Studies by Munir et al. (2019) and Krishnan et al. (2020) generally employed a single microcontroller and monitored limited environmental parameters, primarily soil moisture and temperature. Similarly, Ariffin and Zin (2021) utilized a NodeMCU with the Blynk platform but focused

on only a small number of environmental variables. In contrast, the system developed in this study integrates two microcontrollers with separate responsibilities for sensor data acquisition and network communication, which improves processing stability and data transmission reliability. Furthermore, the integration of multiple environmental sensors, including soil moisture, temperature, light intensity, and rainfall, enables more comprehensive field monitoring and more adaptive irrigation control. This design exhibits greater robustness and is more suitable for direct field implementation compared to earlier IoT architectures.

A relay module was used to control the irrigation pump automatically based on soil moisture readings. When the moisture level dropped below the 50% threshold, the relay triggered the water pump to irrigate the soil. Once the optimal moisture level was reached, the pump automatically shut off. The complete circuit configuration and sensor interconnections are illustrated in Figure 4.

During system implementation, water was stored in a container connected to the irrigation pump, which channelled water through flexible tubing into pots containing *Amorphophallus muelleri* (porang) plants. After activation and successful network connection, the sensors continuously monitored environmental parameters and transmitted data to the Blynk cloud through the NodeMCU ESP8266 module. The system successfully performed automatic irrigation control based on real-time soil moisture data and allowed continuous environmental monitoring through a smartphone interface. The overall setup of the implemented system is shown in Figure 5.



**Figure 5** Implementation setup of the IoT-based automatic irrigation and environmental monitoring system for *Amorphophallus muelleri* (porang) plants.

### 3.2 Calibration Sensors

Calibration was performed on three main sensors: the DHT22 temperature sensor, the YL-69 soil moisture sensor, and the BH1750 light intensity sensor. Functional tests were also carried out on the rainfall sensor and the water pump to ensure automatic operation of the irrigation system. Furthermore, connectivity and data monitoring tests were conducted using the Blynk application. The results of the calibration and performance evaluations are presented as follows.

#### 3.2.1 Calibration of the Temperature DHT22 Sensor

The DHT22 temperature sensor was calibrated against a standard thermohygrometer HTC-1 to ensure accuracy across a range of temperatures. During calibration, both the sensor and the reference device were positioned side by side in an enclosed room, where the ambient temperature varied between 1.6°C and 42.0°C.

Based on the calibration results shown in Figure 6, the linear regression equation is expressed as Equation 1:

$$y = 0.9926 x + 0.0685 \quad (1)$$

The coefficient of determination is  $R^2 = 0.99989$  indicating a very strong linear relationship between the DHT22 and the standard thermohygrometer. The average error value is 2.19%, corresponding to an accuracy rate of 97.81%. This result is better than that reported by Fatimatuzzahra et al. (2020), which showed an average error of 2.99% (Fatimatuzzahra et al., 2020).

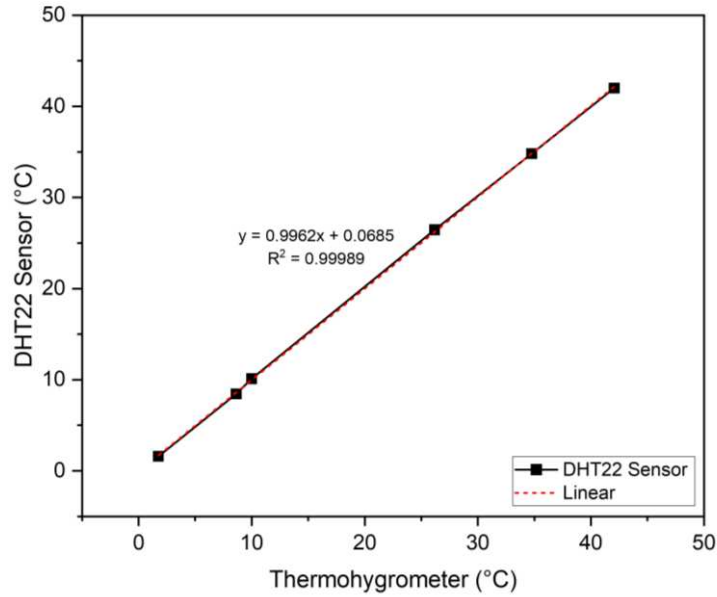

**Figure 6** Calibration results of the DHT22 temperature sensor.

### 3.2.2 Calibration of Soil Moisture YL-69 Sensor

The calibration of the YL-69 soil moisture sensor is performed by comparing the sensor readings with a standard soil moisture meter. The calibration is conducted under dry soil conditions, with water gradually added in 100 mL increments from 100 mL to 1000 mL. Each variation in water volume is measured seven times to obtain average data for each condition.

Based on the calibration results shown in Figure 7, the linear regression equation is expressed as Equation 2:

$$y = 0.9862x + 0.0573 \tag{2}$$

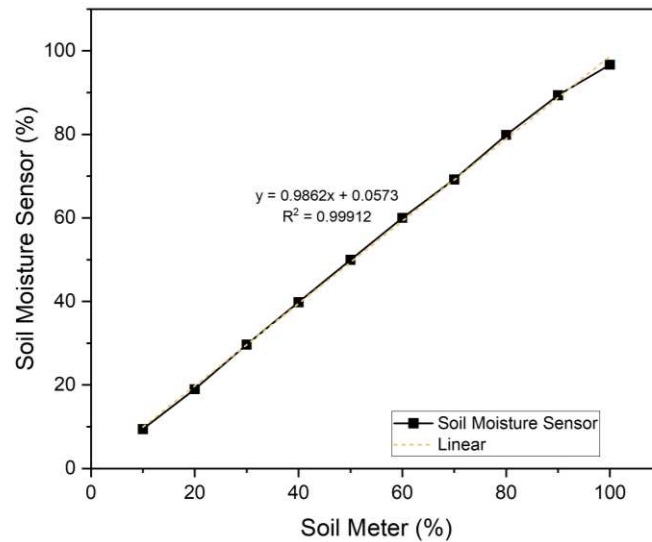

**Figure 7** Calibration results of the YL-69 soil moisture sensor.

The coefficient of determination is  $R^2 = 0.99912$ , indicating a very strong linear relationship between the sensor and the standard soil moisture meter. The average error value is 1.75%, corresponding to an accuracy rate of 98.25%. This calibration result also demonstrates an improvement in accuracy compared to the study by Umbu (2023), which reported an error value of 4.42% (Umbu., 2023). Although the calibration shows excellent performance under controlled laboratory conditions,

the sensor response may vary under practical field environments. Variations in soil composition, temperature, humidity, and environmental dynamics can introduce additional uncertainties that slightly affect measurement accuracy. Similar findings have been reported for low-cost soil moisture sensors, where calibration models developed in laboratory settings did not always maintain the same accuracy when deployed in real agricultural fields (Abdelmoneim et al., 2025).

### 3.2.3 Calibration of Light Intensity BHI750 Sensor

The calibration of the BH1750 light intensity sensor is performed by comparing its readings with those of a standard measuring device, namely a light meter. The calibration process is conducted using an incandescent light source. The sensor and the measuring device are placed close together at varying distances from the light source, while maintaining constant light intensity. Data is collected seven times for each distance variation, with a one-minute interval between measurements.

Based on the calibration results shown in Figure 8, the linear regression equation is expressed as Equation 3:

$$y = 1.0019x + 9.2832 \quad (3)$$

The coefficient of determination ( $R^2$ ) is 0.99999, indicating an almost perfect linear relationship between the sensor readings and the standard measurements. The average error value is 5.09%, corresponding to an accuracy rate of 94.91%. This result demonstrates a high level of precision and shows improvement compared to the study by Pebralia et al. (2024), which reported an error of 9.87% (Pebralia et al., 2024).

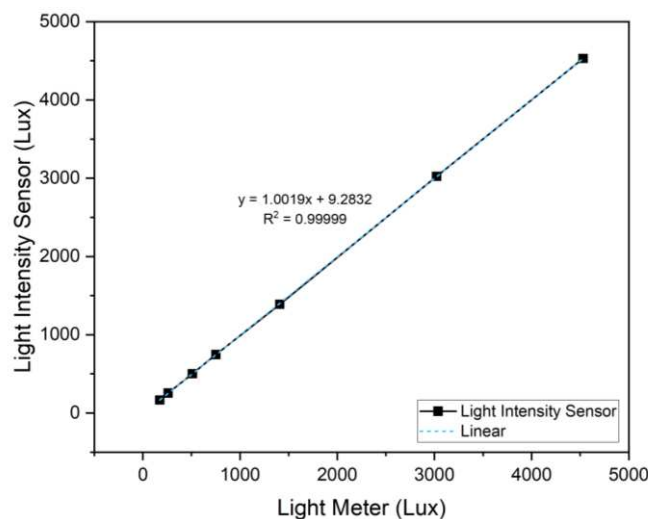

**Figure 8** Calibration results of the BH1750 light intensity sensor.

### 3.2.4 Rainfall Sensor Testing

The rainfall sensor testing was conducted by recording the analog output readings generated by the sensor. Under dry conditions, the sensor output remained stable at a maximum reading of 1023, which gradually decreased as the moisture level on the sensor surface increased (Widodo & Sumaedi, 2023).

Based on the test results, analog readings in the range of 1023 to 640 indicate no rainfall, readings in the range of 639 to 320 indicate light rain, and readings below 319 indicate heavy rain. The testing was carried out over a 24-hour period, with data collected at 30-minute intervals. The results of the rain sensor test are presented in Figure 9.

### 3.2.5 Water Pump Testing

The water pump testing was conducted to evaluate the system's response to the YL-69 soil moisture sensor readings on taro plants. The water pump is automatically activated when the soil moisture level falls below the predefined 50% threshold. The upper threshold is set at 50%, and the

lower threshold at 49%, determining when the pump turns on and off automatically. The test results are presented in Table 1.

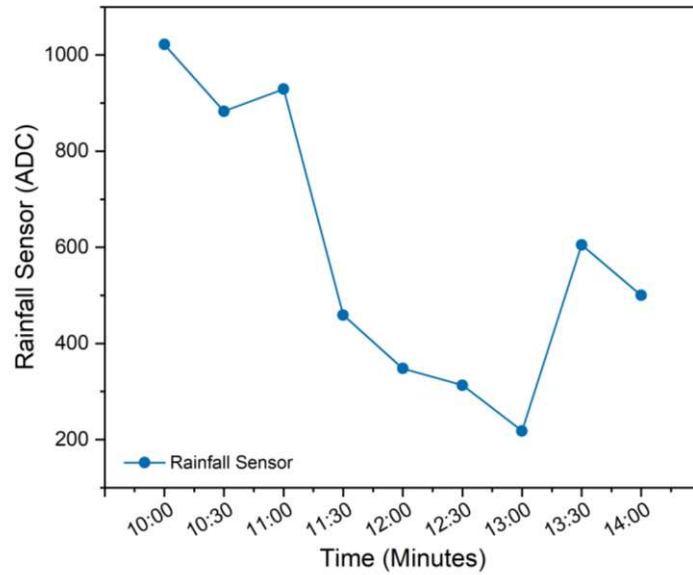

Figure 9 Results of the rainfall sensor testing.

Table 1 Results of water pump testing based on soil moisture readings.

Soil Moisture (%)	Pump ON	Pump OFF	Delay (Minute)	Description
49	Yes	-	1	ON
50	-	Yes	1	OFF

### 3.3 System Test Results

The testing of the automatic irrigation system and environmental parameter monitoring (temperature, soil moisture, light intensity, and rainfall) was conducted over three consecutive days, from 06:00 to 18:00 WITA, with a duration of 12 hours each day.

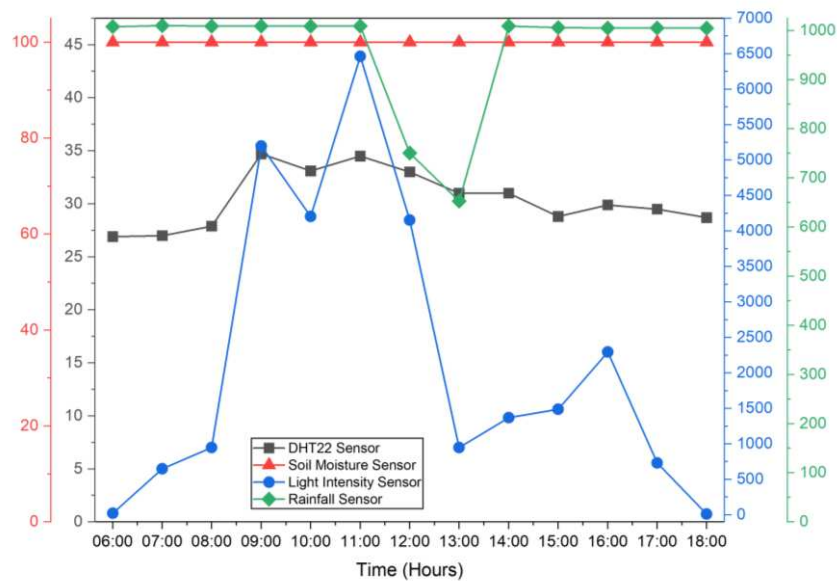

Figure 10 Results of system testing on the first day.

### 3.3.1 First Day Test Results

On the first day, the planting medium used was manure, which has the capacity to absorb and retain large amounts of water. Rainfall early in the morning before testing caused the soil to be saturated from the start of data collection. The DHT22 sensor recorded air temperatures ranging from 26.9°C to 34.7°C, with the maximum temperature recorded at 09:00. The YL-69 soil moisture sensor showed a constant value of 100% throughout the testing period, due to the high moisture content from the manure and additional rainfall during the day. The rainfall sensor initially recorded values between 1005 and 1010, then dropped drastically to 653 at 13:00, consistent with the 60-minute measurement intervals. Meanwhile, the BH1750 light intensity sensor recorded an increase from 25 lux at 06:00 to 6464 lux at 11:00. Since the soil moisture remained high (above 50%), the system did not activate the water pump.

### 3.3.2 Results of the Second Day Testing

On the second day, the air temperature was detected to rise from 25°C in the morning to 36.2°C at 10:00 WITA, then decreased to 30.8°C in the afternoon. Soil moisture initially ranged from 98% to 100% until 14:00 WITA, then dropped to 48% at 17:00 WITA due to the increase in temperature and light intensity. When the soil moisture fell below 50%, the automatic water pump was activated to irrigate the plants. The rainfall sensor values ranged from 982 in the morning to between 1006 and 1011 in the afternoon and evening. The BH1750 sensor recorded a maximum light intensity of 30,415 lux at 09:00 WITA, which gradually decreased to 9 lux by 18:00 WITA. The activation of the pump successfully maintained soil moisture within the optimal range.

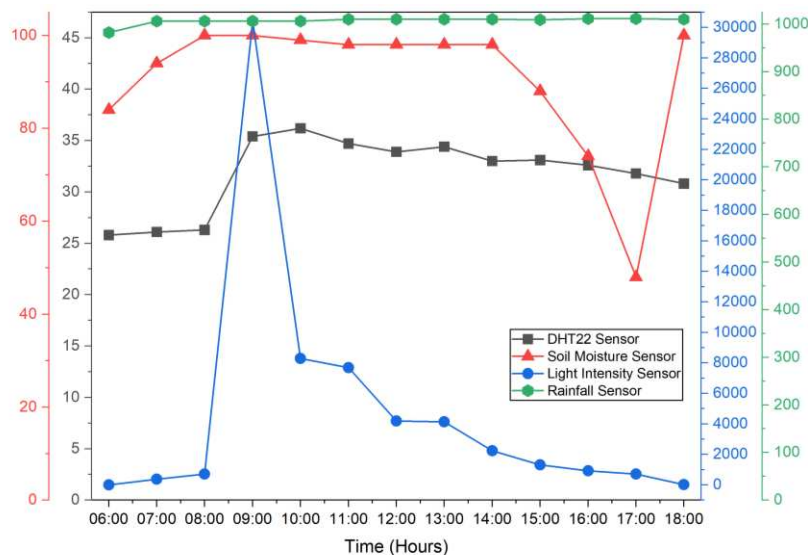

Figure 11 Results of system testing on the second day.

### 3.3.3 Results of the Third Day Testing

On the third day, the environment experienced extreme changes. The temperature rose from 26.0°C at 06:00 WITA to 45.2°C at 09:00 WITA, then dropped to 31.6°C at 18:00 WITA. The light intensity measured by the BH1750 sensor increased from 109 lux to 22,825 lux at 09:00 WITA, then decreased to 19 lux in the afternoon. The combination of high temperature and light accelerated evaporation, causing soil moisture to drop from 95% to 46% by 17:00 WITA. When the moisture level crossed the threshold, the system automatically activated the water pump, raising the moisture level back to 100% by 18:00 WITA. The rain sensor recorded stable values between 912 and 1008, with no indications of rain.

Overall, the three-day field testing demonstrates that the proposed system consistently captured dynamic environmental variations and responded appropriately through automatic irrigation control. While the temporal trends for each day are illustrated in Figures 10–12, a more concise quantitative

comparison is necessary to evaluate the overall system performance. Therefore, a statistical summary of the recorded parameters, including the minimum, maximum, and mean values of temperature, soil moisture, rainfall intensity, and light intensity, is presented to highlight daily variability and monitoring stability. The summarized results are provided in Table 2.

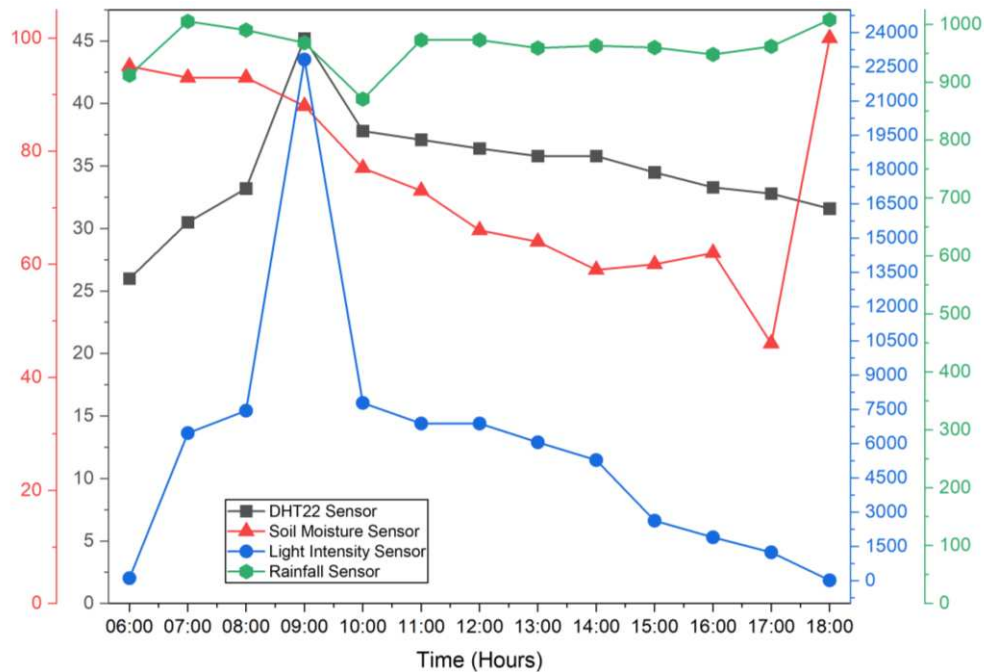

Figure 12 Results of system testing on the third day.

Table 2 Statistical summary of environmental parameters during the three-day field testing.

Day	Temperature (°C)			Soil Moisture (%)			Rainfall (ADC)			Light Intensity (lux)		
	Min	Max	Mean	Min	Max	Mean	Min	Max	Mean	Min	Max	Mean
Day 1	26.9	34.5	30.4	100	100	100.0	653	1010	960.3	10	5195	2051.7
Day 2	25.8	36.2	31.9	48	100	90.7	982	1011	1006.7	6	8289	2586.2
Day 3	26.0	45.2	34.6	46	100	75.1	871	1008	962.7	109	7786	2808.4

As shown in Table 2, the system maintained stable monitoring performance across the three testing days while successfully capturing daily environmental fluctuations. The increase in average temperature and light intensity on the third day corresponded with a noticeable decrease in soil moisture, indicating higher evapotranspiration and validating the automatic irrigation response. These results confirm the reliability of the proposed system for real-time environmental monitoring and adaptive irrigation control under varying field conditions.

#### 4. CONCLUSION

An automatic irrigation system and Internet of Things (IoT)-based monitoring system for porang crops have been successfully designed and implemented. This system consists of DHT22 temperature and humidity sensors, YL-69 soil moisture sensors, BH1750 light intensity sensors, and rain gauge sensors, all integrated with an Arduino Uno microcontroller, a NodeMCU ESP8266 Wi-Fi module, and the Blynk application for real-time monitoring. Calibration results demonstrate a high level of accuracy, with error values of 2.19% for the DHT22 temperature sensor, 1.75% for the soil moisture sensor, and 5.09% for the light intensity sensor. The rainfall sensor also performs well in distinguishing dry conditions, light rain, and heavy rain based on ADC readings. Testing over three days showed that the system was able to detect changes in environmental conditions and automatically activate the water pump when soil moisture fell below a threshold of 50%.

This system has proven effective in maintaining soil moisture at an optimal level and enhancing water use efficiency during the cultivation of porang plants. Additionally, the environmental data obtained can be monitored in real time through the Blynk application, making this system highly applicable within the concept of smart farming, especially for various types of land with specific irrigation needs. Despite the promising performance, the system still has several limitations, including dependence on single-node deployment and potential measurement variability under dynamic field conditions. Future work will focus on expanding the system into a multi-node architecture and integrating intelligent data analytics or artificial intelligence to enhance decision-making and irrigation efficiency.

## REFERENCE

- Abdelmoneim, A. A., Al Kalaany, C. M., Khadra, R., Derardja, B., & Dragonetti, G. (2025). Calibration of low-cost capacitive soil moisture sensors for irrigation management applications. *Sensors*, *25*(2), 343. <https://doi.org/10.3390/s25020343>.
- Ariffin, N., & Zin, R. M. (2021). An Internet of Things (IoT)-based plant irrigation and monitoring system for chili plant. *Evolution in Electrical and Electronic Engineering*, *2*(2), 70–76. <https://doi.org/10.30880/eeee.2021.02.02.009>.
- Fatimatuzzahra, F., Didik, L. A., & Bahtiar, B. (2020). Analisis periodisitas gempa bumi di wilayah Kabupaten Lombok Barat dengan menggunakan metode statistik dan transformasi wavelet. *Jurnal Fisika dan Aplikasinya*, *16*(1), 33. <https://doi.org/10.12962/j24604682.v16i1.5717>.
- Gupta, S., Chowdhury, S., Govindaraj, R., Amesho, K. T. T., Shangliar, S., Kadhila, T., & Ikela, S. (2025). Smart agriculture using IoT for automated irrigation, water and energy efficiency. *Smart Agricultural Technology*, *12*, 101081. <https://doi.org/10.1016/j.atech.2025.101081>.
- Hidayat, T. (2017). Internet of Things smart agriculture on ZigBee: A systematic review. *Jurnal Telekomunikasi dan Komputer*, *8*(1), 75. <https://doi.org/10.22441/incomtech.v8i1.2146>.
- Irsyam, M., Tanjung, A., & Studi Teknik Elektro Universitas Riau Kepulauan Batam, P. (2019). Sistem otomasi penyiraman tanaman berbasis Telegram. *Sigma Teknika*, *2*(1), 81–94.
- Krishnan, R. S., Julie, E. G., Robinson, Y. H., Raja, S., Kumar, R., Thong, P. H., & Son, L. H. (2020). Fuzzy logic-based smart irrigation system using Internet of Things. *Journal of Cleaner Production*, *252*, 119902. <https://doi.org/10.1016/j.jclepro.2019.119902>.
- Liu, X., Zhao, Z., & Rezaiepanah, A. (2025). Intelligent and automatic irrigation system based on Internet of Things using fuzzy control technology. *Scientific Reports*, *15*, 14577. <https://doi.org/10.1038/s41598-025-98137-2>.
- Morchid, A., Jebra, R., Khalid, H. M., El Alami, R., Qjidaa, H., & Ouazzani Jamil, M. (2024). IoT-based smart irrigation management system to enhance agricultural water security using embedded systems, telemetry data, and cloud computing. *Results in Engineering*, *23*, 102829. <https://doi.org/10.1016/j.rineng.2024.102829>.
- Munir, M. S., Bajwa, I. S., & Cheema, S. M. (2019). An intelligent and secure smart watering system using fuzzy logic and blockchain. *Computers and Electrical Engineering*, *77*, 109–119. <https://doi.org/10.1016/j.compeleceng.2019.05.006>.
- Pebralia, J., Fendriani, Y., Afrianto, M. F., & Syaila, C. N. (2024). Rancang bangun sistem pengukuran intensitas cahaya, suhu, dan kelembaban ruangan berbasis sensor DHT11 dan BH1750. *JOP*, *10*(1), 37–42.
- Rahayuningsih, Y., Nawawi Al Bantani, J. S., & others. (2020). Berbagai faktor internal dan eksternal serta strategi untuk pengembangan porang (*Amorphophallus muelleri*) di Provinsi Banten. *Jurnal Kebijakan Pembangunan Daerah*, *4*(2), 77–92.
- Reghukumar, A., & Vijayakumar, V. (2019). Smart plant watering system with cloud analysis and plant health prediction. *Procedia Computer Science*, *165*, 126–135. <https://doi.org/10.1016/j.procs.2020.01.088>.
- Sari, R., & Suhartati. (2015). Tumbuhan porang: Prospek dibudidayakan sebagai salah satu sistem agroforestry. *Info Teknis EBONI*, *12*(2), 97.
- Sintia, W., Hamdani, D., & Risianto, E. (2018). Rancang bangun sistem monitoring kelembaban tanah dan suhu udara berbasis GSM SIM900A dan Arduino Uno. *Jurnal Kumpulan Fisika*, *1*(2), 60–65.
- Umbu, A. B. S. (2023). Kalibrasi sensor kelembapan tanah YL-69 untuk sistem pengukuran kelembapan tanah berbasis Arduino Uno. *OPTIKA: Jurnal Pendidikan Fisika*, *7*(1), 62–71.

- 
- Widodo, A., & Sumaedy, A. (2023). Prototype deteksi hujan berbasis Arduino Uno menggunakan rain drop sensor module. *Jurnal Teknik Informatika STMIK Antar Bangsa*, *9(1)*, 18–24.
- Zulfikar, M. (2018). Perancangan sistem penyiraman tanaman otomatis berbasis mikrokontroler ATmega328. *Journal of Informatics and Computer Science*, *4(1)*, 75-90.