

Analysis of Solar Power Plant Planning for Lighting Dragon Fruit Orchards in Silimakuta Village, Pakpak Bharat

Alfonsus Sinamo¹, Muhammad Erpandi Dalimunthe², Haris Gunawan³

Electrical Engineering Study Program, Faculty of Science And Technology, Pembangunan Panca Budi University,
Jln. Jend.Gatot Subroto Km. 4,5 Medan Provinsi Sumatera Utara

Article Info	ABSTRACT
<p>Keywords: PLTS Lighting dragon fruit orchards solar energy</p>	<p>The use of electrical energy as a lighting source in dragon fruit orchards in remote areas such as Silimakuta Village often faces challenges due to limited access to electricity from the state electricity company (PLN). Therefore, efficient and sustainable alternative energy sources are needed, one of which is through Solar Power Plants (PLTS). This study aims to calculate the power requirements and capacity of the PLTS system required to meet lighting needs in dragon fruit orchards. The research problem formulation includes how to calculate the power requirements of a PLTS system and the required power capacity. The problem definition focuses on calculating the power requirements of each component and the amount of power generated by the system to determine the number of solar modules. The research method used was to calculate the power consumption of lighting lamps, system efficiency, and the potential solar irradiation in the area. The results show that a PLTS system with a certain capacity can optimally meet nighttime lighting needs. This research provides benefits in the form of appropriate PLTS system planning, battery capacity calculations, and the utilization of renewable energy to support sustainable lighting systems in the agricultural sector.</p>
<p>This is an open access article under the CC BY-NC license</p> 	<p>Corresponding Author: Alfonsus Sinamo Electrical Engineering Study Program, Faculty of Science And Technology, Pembangunan Panca Budi University, Jln. Jend.Gatot Subroto Km. 4,5 Medan Provinsi Sumatera Utara alfonsussinamo@gmail.com</p>

INTRODUCTION

Dragon fruit is a type of cactus that is very suitable for cultivation in Indonesia. Dragon fruit has many health benefits such as maintaining immunity, improving digestion, and preventing heart disease and cancer. Dragon fruit is a seasonal plant that will bear fruit in its season. This is because this plant requires light for the mating process (photosynthesis). Using only sunlight for the mating process will not be enough to make this plant bear fruit consistently. Therefore, adding lighting at night can make this plant able to bear fruit outside of its season. With the use of technology, it will be very helpful for dragon fruit plants to bear fruit outside of their season. Because by adding light at night, this will clearly help increase the harvest, because dragon fruit will continue to bear fruit regardless of the season. So that when dragon fruit production is low, with the addition of lighting, dragon fruit will continue to produce so that farmers can dominate the market. In Silimakuta village,

lighting is done by utilizing electrical energy from PLN which is connected to the lights, so that dragon fruit farmers in Silimakuta village have to spend quite a lot of money every month just to pay for electricity, because lighting uses electrical power for 10-12 hours a day, consuming large amounts of electricity, so this is one of the problems in dragon fruit lighting. By utilizing solar power plants (PLTS). In general, the main components of PLTS are solar panels, solar charge controllers (SCC), batteries, and other components such as inverters, if the DC voltage source obtained from PLTS will be converted into AC voltage. In order for a PLTS-based system to work well, it is necessary to calculate the load, quantity, capacity, and specifications of the equipment to be used.

METHOD

The research method began with a site survey to identify the number of lighting points needed and the duration of lighting operations in the dragon fruit orchard at night. Based on this data, daily energy requirements were calculated using a formula. Next, the capacity of the solar power plant system, including solar panels, batteries, and other supporting components, was calculated, taking efficiency into account. Average solar irradiance data was obtained from official sources such as the BMKG (Meteorology, Climatology, and Geophysical Agency) or PVGIS (PVGIS). The solar power plant system design focused on the suitability of the required power capacity and the system's ability to provide sufficient energy sustainably under local environmental conditions.

This study included research methods applicable to the research process, including observation, interviews, and literature review. The instruments used were as follows:

a. Direct Observation/Review

This activity was conducted in Silimakuta Village, West Pakpak, by conducting direct observations of the dragon fruit fields. This activity collected several analytical results.

b. Interviews

The interview process was conducted during the observation with an interview with one of the dragon fruit farmers and the owner of the dragon fruit field in Silimakuta Village, West Pakpak. Interviews were conducted to learn about experiences and obtain accurate information to aid in the research.

c. Literature Review

Studying the literature that will be used as reference material in this research.

Table 1. Tools and Materials

NO.	Tools and Materials	Description
1.	Solar Cell 560Wp Monocrystalline Hi-MO 6 Explorer MODEL:LR5-72HTH 560	38 pcs
2.	Solar Charge Controller Maximum Power Point Tracker (MPPT) 100A	6 pcs
3.	Baterai 48V 100AhLiFePO4	18 pcs
4.	LED Buah Naga Hannochs 15Watt	267 pcs
5.	Inverter ATO-PSWI-48V-5000W	1 pcs
6.	MCB DC 100A NBT2-125DC	1 pcs
7.	MCB AC 25 A Schneider	2 pcs



Figure 1. Research Location

This research was conducted in Silimakuta Village, Pakpak Bharat Regency, North Sumatra. This village was chosen because it has high sunlight potential and is not yet fully connected to the PLN electricity grid, making it highly suitable for implementing a solar power plant (PLTS). The research site is a dragon fruit orchard covering approximately 5,000 square meters. Adequate lighting is planned for the land to support plant growth at night.

RESULTS AND DISCUSSION



Figure 2. Dragon Fruit Orchard Used as a Research Site

Solar Energy Potential

The estimated average solar irradiance in Silimakuta Village, Pakpak Bharat Regency, North Sumatra, based on data from the Aek Godang Meteorological Station, the closest BMKG station to the Pakpak Bharat region, recorded that the average daily solar irradiance in March 2024 was approximately 14.4 MJ/m²/day, equivalent to 4.0 kWh/m²/day (BMKG 2024).

Electricity Requirements

The energy requirements for the dragon fruit orchard lighting system are determined by the number of light points, the type of light used, and the length of nighttime operation. In this study, 15-watt Buah Naga Brand (Hannochs) LED lamps were used, which are known to be energy efficient and have high luminous efficiency for lighting open areas. A

total of 267 lamps, each rated at 15 watts, were used. The lights are operated for 12 hours per day, 1 light illuminates 3 dragon fruit tree stakes with a distance of about 2.5 meters from one dragon fruit stake to another.



Figure 3. Dragon Fruit Tree Planting Spacing

Based on these specifications, the daily electrical energy consumption can be calculated as follows:

$$E = P \times T$$

$$E = 15 \text{ Watts} \times 12 \text{ hours} = 180 \text{ Wh/day}$$

With a dragon fruit orchard area of 5,000 square meters and 267 lamps, the total requirement is as follows:

$$E_{\text{Total}} = 180 \text{ Wh/day} \times 267 = 48,060 \text{ kWh/day}$$

$$\text{System Efficiency} = (100\% - 40\%) = 60\% = 0.6$$

$$E_{\text{Total}} = (48,060 \text{ kWh/day}) / 0.6 = 80,100 \text{ Watts}$$

This is the net energy requirement (output) that must be supplied by the solar power system each day.

Solar Panel Capacity Requirements

The electrical voltage generated by solar panels will not always be stable. This is because voltage production depends on the level of solar radiation. During the ideal time (10:00-14:00 WIB), with the air temperature and clear skies (without clouds), solar panel performance will be optimal. However, in the morning or when the sun is obscured by clouds, the solar panel voltage will decrease. Based on the ideal solar radiation time, the optimal photovoltaic process lasts 4 hours per day. Therefore, the calculation of the number of solar panels used in a dragon fruit orchard is as follows:

Solar panels

= total power : optimal time

= 80,100 Watts : 4 hours

= 20,025 Wp (Watt Peak)

20,025 Wp : 560 Wp = 200.25 rounded to 21,000 Wp

To achieve 21,000 Watt Peak power, solar panels with a total capacity of 560 Wp are required. Therefore, this plan assumes a 560 Wp solar panel per panel. Therefore, 38 solar panels are needed in parallel to meet the required power capacity.

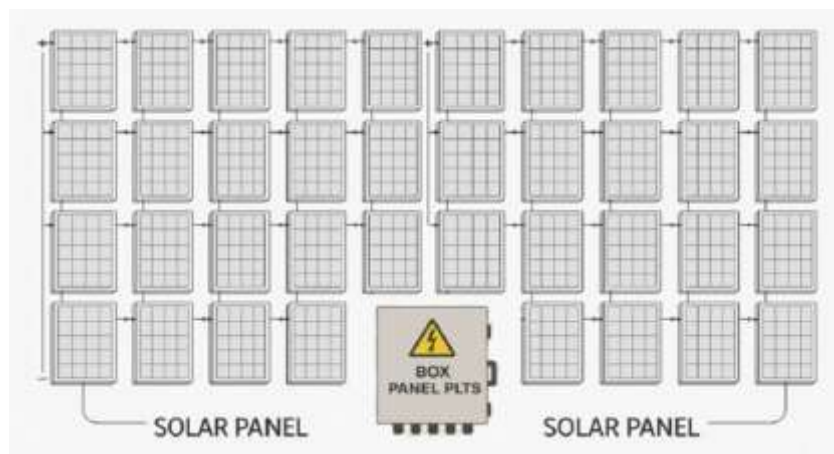

Figure 4. Parallel Solar Cell Installation

Battery Capacity Requirements

The minimum battery capacity required for lighting in the Dragon Fruit Garden is calculated as follows.

Adjusting Electrical Power to System Efficiency

The required electrical power is calculated by considering a system efficiency of 60%. The calculation is as follows:

$$\text{Required Electrical Power} = 80,100 \text{ kWh} / 0.60 = 133,500 \text{ Wh}$$

Therefore, the reference electrical power used to determine battery capacity is 133,500 Wh.

Choosing Battery Specifications

Batteries are available in various specifications on the market. This study assumes the use of batteries with the following specifications:

$$\text{Battery Voltage (V)} = 48\text{V}$$

$$\text{Battery Capacity (Ah)} = 100\text{Ah}$$

Therefore, the power capacity per battery can be calculated as follows:

$$\text{Power Per Battery} = V \times \text{Ah} = 48\text{V} \times 100\text{Ah} = 4,800\text{Wh}$$

Therefore, the number of batteries required to meet the system's power requirements is calculated using the formula:

$$\text{Number of Batteries} = (\text{Required electrical power}) / (\text{Power per battery}) = 133,500\text{Wh} / 4,800\text{Wh} = 27.81 \text{ Units}$$

Rounded up to 28 Battery Units

Inverter Requirement

Based on the design data, the lighting system consists of 267 lights, each with a power of 15 Watts. To ensure a safe design, it is assumed that all lights can be turned on simultaneously. Thus, the total load power that the inverter must supply is calculated as follows:

$$\text{Total power} = 267 \times 15 \text{ Watts} = 4,005 \text{ Watts}$$

To ensure the inverter can operate optimally with sufficient power reserves, and accommodate load fluctuations and initial current surges during the lighting process, the inverter's output capacity is recommended to exceed the total load power requirement. Therefore, the recommended inverter is one with an output capacity of:

$$5,000 \text{ Watts}$$

Selecting an inverter with a capacity greater than the total load aims to improve system reliability, extend the inverter's lifespan, and ensure optimal performance during system operation.

Solar Charge Controller (SCC) Requirements

The type of solar panel used in this system is monocrystalline with the following technical specifications:

$$\text{Power output (Pmax)} = 560 \text{ Watts}$$

$$\text{Maximum power voltage (Vmp)} = 44 \text{ V}$$

$$\text{Maximum power current (Imp)} = 13 \text{ A}$$

$$\text{Open circuit voltage (Voc)} = 52 \text{ V}$$

$$\text{Short circuit current (Isc)} = 14 \text{ A}$$

$$\text{Physical dimensions} = \text{approximately } 2278 \text{ mm} \times 1134 \text{ mm} \times 35 \text{ mm.}$$

Therefore, the SCC power can be calculated as follows:

$$\text{SCC Power} = I_{SC} \times \text{Number of Panels} = 14 \times 38 = 532 \text{ A}$$

Based on the calculation, the required SCC is approximately 532 Amperes.

However, this value is very large for a single SCC; typically, SCCs of this capacity are not practical or available. For systems with high current requirements like this, multiple SCCs of smaller capacities are used in parallel. For example, using several 6 100A MPPT SCCs connected to meet the total current requirements.

Solar Panel Design Schematic

The solar panel system design for the Dragon Fruit Orchard in Silimakuta Village, Pakpak Bharat, is as follows:

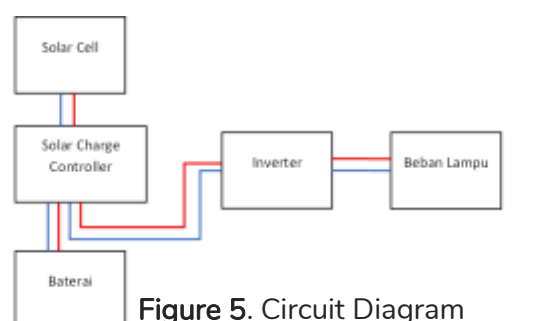

Figure 5. Circuit Diagram

CONCLUSION

Based on the analysis and planning conducted, it can be concluded that designing a solar-powered dragon fruit orchard lighting system in Silimakuta Village, Pakpak Bharat, requires careful calculation and planning. Accurately determining the minimum electrical energy requirements is crucial before purchasing solar power system components. This step aims to avoid purchasing inappropriate components. Based on the data obtained, the average daily solar irradiation potential in Silimakuta Village in March 2024 was approximately 14.4 MJ/m²/day, or equivalent to 4.0 kWh/m²/day. With this irradiation potential, the planned lighting system includes 267 LED lamps with a capacity of 15 Watts per lamp, resulting in a total power requirement of 80,100 Watts. To meet this power requirement, a solar panel capacity of 20,025 Wp is required. Using 560 Wp solar modules per unit, a total of 38 solar panels are required. Battery capacity calculations indicate that 84,316 Wh of storage capacity is required. With a battery capacity of 4,800 Wh per unit (48 V, 100 Ah battery), a total of 28 batteries are required. A 100 A Solar Charge Controller (SCC MPPT) is used to regulate battery charging. Since the total current required is approximately 532 A, the SCCs will be arranged in parallel to optimally meet system requirements. A 25 A AC MCB and a 100 A DC MCB are used for system protection. Through careful calculations, the design for the number of solar modules, battery capacity, SCC configuration, and number of lamps meets the lighting requirements of the dragon fruit orchard. Utilizing renewable energy through this solar power system is expected to increase energy efficiency, support environmental sustainability, and reduce dependence on fossil fuels.

REFERENCE

- S. A. Anda, U. F. S. S. Pane, and B. Anwar, "Lighting Design for Dragon Fruit Plants Using Solar Cells Based on the Internet of Things," *Triguna Dharma Computer Systems Journal (JURSIK TGD)*, vol. 3, no. 6, pp. 240–250, Nov. 2024, doi: 10.53513/jursik.v3i6.8873.
- Priska Restu Utami, Widyastuti, and Marliza, "ANALYSIS OF SOLAR POWER GENERATION CALCULATIONS FOR PASSION FISH PARK IN RT 01/RW 08, MAMPANG VILLAGE, PANCORAN MAS, DEPOK CITY," *Multidisciplinary Community Service Journal*, vol. 1, no. 2, Aug. 2022, doi: 10.56127/jammu.v1i2.198.
- M. E. Dalimunthe, "Analysis of Solar Cell Potential in Building I of Pembangunan Panca Budi University," *Fidelity: Journal of Electrical Engineering*, vol. 5, no. 2, pp. 41–50, June. 2023, doi: 10.52005/fidelity.v5i2.149.
- P. Siagian, M. E. Dalimunthe, B. Siregar, M. Fadlan, and R. A. Frasasti, "The Cost of Islamic Boarding School Electricity Bills is Lowered by Installing Solar Cells on Grid Limiters," *Bestari Community Service Journal*, vol. 1, no. 8, pp. 895–904, Dec. 2022, doi: 10.55927/jpmb.v1i8.1954.
- Andreansyah, M. E. Dalimunthe, and D. Lesmana, "Analysis of Aquaponics Solar Panel Innovation in Building C of Pembangunan Panca Budi University," *Fidelity: Jurnal Teknik Elektro*, vol. 6, no. 1, pp. 60–63, Jan. 2024, doi: 10.52005/fidelity.v6i1.201.
- S. Anisah and A. Darma Tarigan, "ROOF SOLAR POWER PLANT PLANNING ON GRIND

- AS AN ENVIRONMENTALLY FRIENDLY ALTERNATIVE ENERGY SOURCE,” Journal of Information Technology and Computer Science (INTECOMS), vol. 6, no. 1, 2023.
- S. Anisah and A. Darma Tarigan, “ROOF SOLAR POWER PLANT PLANNING ON GRIND AS AN ENVIRONMENTALLY FRIENDLY ALTERNATIVE ENERGY SOURCE,” Journal of Information Technology and Computer Science (INTECOMS), vol. 6, no. 1, 2023.
- R. Rahmaniari, M. B, and A. Juniadi, “Utilization of Solar Panel EBT Technology Innovation on a Stick Shaving Machine for Community Empowerment in Bandar Senembah Village,” Jurnal SOLMA, vol. 12, no. 3, pp. 1186–1194, Dec. 2023, doi: 10.22236/solma.v12i3.12860.
- R. Rahmaniari, K. Khairul, A. Junaidi, and D. K. Sari, “Analysis of Shadow Effect on Solar PV Plant using Helioscope Simulation Technology in Palipi Village,” JTEV (Jurnal Teknik Elektro dan Vokasional), vol. 9, no. 1, p. 75, May 2023, doi: 10.24036/jtev.v9i1.122372.
- “Analysis of Power Transformer Oil Insulation Capability Against Breakdown Voltage Due to Temperature and Loading,” Journal of Computer Science, Information Technology and Telecommunication Engineering, Feb. 2025, doi: 10.30596/jcositte.v6i1.23674.
- Mhd Hasbi Ramadhan, Haris Gunawan, and Dicky Lesmana, "Analysis of Solar Power System Planning For Street Lighting SUPPLY at Campus I Panca Budi Development University Medan", infokum, vol. 13, no. 04, pp. 918-928, May 2025