

Existence of Fiber Bragg Grating Sensors Based on Power Input and Transmission Distance

Saktioto Saktioto*, Shantela Hanna Mastaria Bintang, Tengku Emrinaldi, Zamri Zamri, Mohd Rendy Samudra, Yan Soerbakti

¹Department of Physics, Faculty of Mathematics and Natural Sciences, University of Riau, Pekanbaru, 28293, Indonesia

(Received April 01, 2025; revised May 14, 2025; accepted May 26, 2025; published online May 30, 2025)

Optical fiber was chosen as a transmission medium because of its ability to transmit data with high power, high speed and low attenuation. Despite these advantages, optical fiber still faces challenges such as attenuation and dispersion which can reduce data transmission performance. This research examines the performance of fiber optic-based communication systems using fiber Bragg grating (FBG) sensors, especially in overcoming linear effects that affect transmission quality. In designing this system, researchers varied the transmission distance from 10 – 150 km, and adjusted the input power from 2 – 20 dBm. The research results show that uniform FBG is more effective in improving signal quality and reducing transmission errors compared to Gaussian FBG. The use of FBGs on coarse wavelength division multiplexing (CWDM) channels also improves system performance, with better quality factors and reduced bit error rates (BER). However, at a distance of more than 60 km, the signal quality decreases due to high noise, which also reduces the Q-factor value, the Q-factor value drops significantly from 61.7699 to 3.0866. Overall, uniform FBG provides more stable and robust data transmission, and increases transmission capacity compared to Gaussian FBG.

Keywords: Bit Error Rate, Fiber Bragg Grating, Q-Factor, Transmission



This is an open access article under the [CC BY-NC](https://creativecommons.org/licenses/by-nc/4.0/) license.
Copyright © 2025 by Author. Published by Physical Society of Indonesia

1. INTRODUCTION

The development of fiber optic telecommunications technology now allows cheap, high-quality, fast, safe, and large-capacity telecommunications facilities to transmit information. With the rapid development of telecommunications technology, the capabilities of fiber optic transmission systems are increasing. In the future, this will change conventional transmission users, especially for long-distance transmission (Gong & Zhang, 2019; El-Hageen et al., 2020). In this technology, the data transfer rate is high compared to other technologies (Fauzi, 2021). Good supplementation is one way to overcome this non-linear effect and interference in good multimedia communication applications. Optical amplifiers usually consist of optical transmitters and optical receivers. Optical transmitters are designed in a format as a linear network that has many properties such as energy consumption, cheap, fast and easy to use photonic systems (El-Gammal et al., 2020; Harpawi et al., 2017).

Fiber Bragg grating (FBG) is a short segment in the core of an optical fiber whose refractive index varies from period (Hidayah & Haikal, 2022). Another compensation method is to use FBG to accommodate deviations caused by optical fibers. Different wavelengths on the FBG are reflected in different distance grinding. The maximum length of travel before starting with a short trip and the fiber is relatively small (Huang et al., 2021; Ikhsan et al., 2018). The concept of FBG was first introduced in 1980 and has also been used in many applications and has been widely studied. It consists of a line that shows the display value of the device from the path to the optical fiber reflecting light depending on the height of the light entering the double slit (Juwari et al., 2022). The discovery of FBG is a milestone in the field of optoelectronics, because reflectors are widely used in various fields such as optical communication and optical sensing. In optical communication, FBG is used as a

*Contact Author: saktioto@lecturer.unri.ac.id

dispersion compensator of optical filters and increases the wavelength in communication systems (Li et al., 2016; Mnati et al., 2021). The communication system uses a frequency (193.1 THz) in the visible or near infrared electromagnetic spectrum region. The communication system is a light wave system that transmits information from one place to another by sending light pulses through optical fibers (Nor et al., 2021). This study analyzes the power and transmission length. However, the presence of a double slit during the transmission process, the amount of energy and power sent and received in each communication process is different from when received. As a result, further research is needed on this, which can cause attenuation during the data transmission process (Qiao et al., 2017).

Since information encoding is measured in wavelength, FBG is better than mechanical or electronic sensors. This is because FBG saves connectors and power, works with nanoscale sensors, and is more sensitive to physical changes. FBG optical sensors, have developed and in recent decades have become a popular research subject (Tahhan et al., 2019; Saktioto et al., 2021). As smart textiles that can monitor human breathing in real time, monitor heart rate, and use Rau as a human heartbeat beam, some developments in research that can be applied to FBG (Skrzetuska & Wojciechowski, 2020). The variables in this study is optical fiber length with a length of 150 km. The response variable in this study is the signal strength value obtained by subtracting the power emitted by the laser. Optical fiber length and optical receiver affect the optical signal value. In this study, coarse wavelength division multiplexing (CWDM) optical fiber material was used to determine the power intensity and wavelength of the optical fiber using the number of transmitters, the number of receivers, the wavelength, and the BER analyzer. optisystem software for modeling and planning with an optical power meter (Pertiwi et al., 2024; Maulana et al., 2023).

2. METHOD

This research is used to analyze the circuit experiment in the FBG sensor section of the Optisystem software and simulate the modeling of the fiber optic network as a communication system by analyzing the power and transmission distance. Furthermore, simulate the performance of several data sensors, finally the spectrum data is varied and input into the optical circuit in the Optisystem software. In this research, Optisystem software is used for research modeling. This research is a circuit simulation, so the tools used are LG computer, optical transmitter, fork 1xN, and optical receiver, while the materials used in the research are FBG sensor, optical fiber, CWDM, and BER analyzer.

The first thing to do is to describe the FBG on the optical fiber by determining the power and transmission distance in the form of a FBG. Then, the peak wave results will be defined in the optical system and then measured how long using the FBG we can obtain information about how the peak wave receiver occurs in the FBG. Optical fiber on Bragg can be used in applications to produce power and transmission distance with a BER analyzer that will be passed through the FBG. An optical fiber passes through a Bragg gap after passing through the Bragg gap the light is filtered, some of the transmitter wavelengths are called Bragg wavelengths which shift and are approached by each change in power and transmission distance. The optical circuit design in Optisystem can be seen in Figure 1.

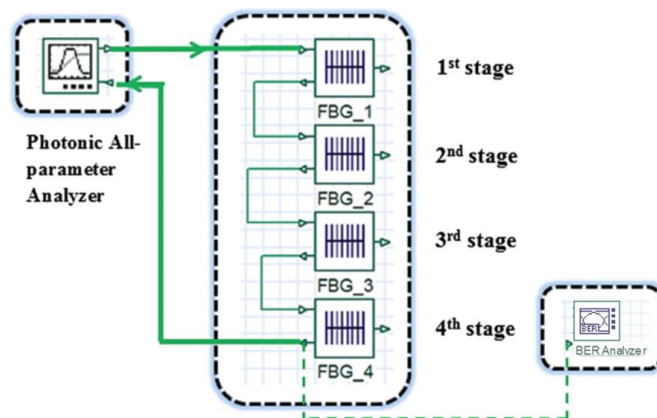

Figure 1. Optical circuit in Optisystem

Figure 1 explains the system transmitter which is assembled consisting of an optical transmitter with a power of 20 dBm to distribute to four branches, then the pulse is connected to the fork 1xN. Then make an effective index with a reference wavelength of 1550 nm and a length of 150 km connected to the first FBG data input design as a power sensor parameter and the second FBG data input design is input as a length sensor. The second reflection signal will be designed by FBG and combined in the optical receiver with a final limit frequency of 0.75 Hz and a gain of 3 using an optical receiver. The output signal on the optical fiber will be connected to the BER analyzer to measure the signal shift and the final step.

3. RESULTS AND DISCUSSION

Optical fiber with FBG sensor can still be used in high power and long transmission distance conditions, but the signal quality is approaching the acceptable tolerance limit, so further optimization is needed. Comparison of transmission and input power using uniform FBG can be seen in Table 1.

Table 1 Comparison of transmission length and input power using uniform FBG

Transmission (km)	Power (dBm)	Q-factor	Min BER
10	2	15.783	1.92×10^{-56}
20	4	28.1389	1.48×10^{-174}
30	6	19.0156	4.55×10^{-81}
40	8	17.2522	4.30×10^{-67}
50	10	15.783	1.92×10^{-56}
60	12	15.2883	4.44×10^{-53}
70	14	13.5408	3.97×10^{-42}

Based on the comparison of the performance of the optical fiber system in Table 1 from a transmission length of 10 – 100 km, it can be seen that the system shows very good performance at short transmission lengths (10 – 30 km). At a length of 10 km with an input power of 2 dBm, the Q-factor value is at 15.783, and the bit error rate (BER) is very low at 1.9154×10^{-56} , indicating optimal signal quality. When the input power is increased to 4 dBm at a length of 20 km, the Q-factor increases significantly to 28.1389, and the BER drops drastically to 1.4777×10^{-17} , indicating improved transmission quality. However, at a length of 30 km with a power of 6 dBm, the Q-factor begins to drop to 19.0156, although it is still in the very good category, with BER remaining low at 4.5527×10^{-81} . The noise tolerance margin remains quite large in this range, as seen from the eye height value above 0.01.

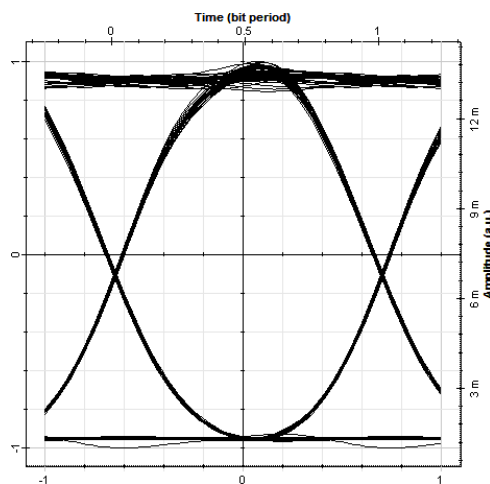

Figure 2. BER pattern power diagram of 2 dBm with length 10 km using uniform FBG

At medium transmission lengths (40 – 70 km), the system begins to show a significant decrease in quality even though the input power continues to increase. At a length of 40 km with a power of 8 dBm, the Q Factor drops to 17.2522, which is still in the acceptable category, but the eye

diagram pattern shows significant narrowing. At a length of 50 km with a power of 10 dBm, the Q-factor remains stable at 15.783, but the dispersion effect begins to be seen in the BER which increases slightly compared to shorter distances. At a length of 70 km with a power of 14 dBm, the Q-factor drops to 13.5408, approaching the tolerance limit, while the eye height decreases to 0.00942743, indicating a decrease in the noise tolerance margin. Overall, the performance of the fiber optic system is very good at short to medium transmission lengths (10 – 50 km) with increasing input power. However, at long transmission lengths (70 – 150 km), the system shows its critical limits, where dispersion and attenuation effects dominate. The BER pattern power diagram of 2 dBm, length 10 km using FBG uniform can be seen in Figure 2.

Figure 2 describes the configuration of 2 dBm input power and 10 km transmission distance, the fiber optic system shows very good performance with a Q-factor value of 15.783, which is far above the minimum standard of 6 for optical communications. BER is recorded very low at 1.9154×10^{-56} indicating almost zero BER, so data transmission can be done reliably. Eye height of 0.00965462 shows adequate noise tolerance margin, ensuring that the signal has sufficient tolerance to external disturbances. Threshold at 0.00557809 is in the optimal position, which allows accurate reading of logic 0 and 1 without significant overlap.

The Eye diagram pattern in this configuration shows a well-open eye, indicating low levels of timing jitter and noise. Signal stability in this condition reflects that the effects of dispersion and attenuation are still within tolerance limits, considering the short transmission distance and sufficient input power. Overall, this 2 dBm power configuration at a transmission distance of 10 km shows optimal transmission performance, with excellent signal quality. This configuration is very suitable for short to medium distance applications without the need for additional optimization such as signal amplification or dispersion compensation. These results provide a strong basis for evaluating performance at greater distances and input powers. The transmission length and input power using Gaussian FBG can be seen in Table 2.

Table 2 Comparison of transmission length and input power using Gaussian FBG

Transmission (km)	Power (dBm)	Q-factor	Min BER
2	10	51.458	0
4	20	25.931	1.3047×10^{-148}
6	30	26.155	4.0391×10^{-151}
8	40	16.312	3.289×10^{-60}
10	50	14.662	5.2423×10^{-49}
12	60	14.614	1.094×10^{-48}
14	70	13.284	1.248×10^{-40}
16	80	5.7518	3.4643×10^{-9}
18	100	5.7518	3.4643×10^{-9}

Figure 3 explains the BER analyzer with an FBG circuit to measure the Q-factor on signals through variations in power, optical fiber length, different uniform and Gaussian FBG sensors. In the graph, the Q-factor value versus length on the horizontal axis is 10 km while the vertical axis is 120. Changes in these values occur because various signal quality factors indicate performance in the communication system.

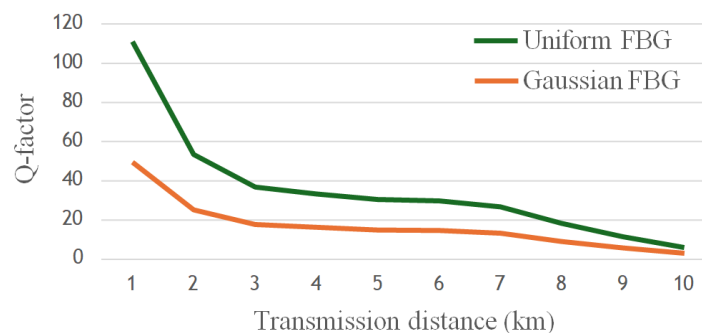

Figure 3. Power and transmission distance with uniform and Gaussian FBG

The graph decreases because the distribution of power is fixed without changes to reduce the impact on the signal, transmission distance variations have a level setting used in the framework and cause the signal to be less concentrated and more susceptible to noise signals. The decrease in the graph can be associated with increasing wavelength and clearer light diffraction making the Q-factor low. As the fiber length increases, the maximum quality value decreases while the minimum bite error frequency increases linearly as the length increases. BER increases with distance, while the Q-factor decreases. The FBG used in the simulation model has a consistent lattice pattern that balances the quality factor. Although Q decreases, the length still increases (Ramadhan et al., 2023).

4. CONCLUSION

This study designed an optical fiber with an FBG sensor at a frequency of 193.1 THz, a power of 20 dBm, and a bit rate of 10 Gbit/s. The signal was transmitted to four laser pulse branches through a 1xN Fork to improve the reliability of communication. The signal receiving channel had a refractive index of 1.45 and a grating length of 2 mm, which effectively amplified the signal. The results showed that this arrangement effectively improved the transmission performance by reducing the width of the eye diagram. However, at a distance of more than 60 km, the quality of the eye diagram decreased due to high noise and unclear eye opening. In addition, the Q-factor value dropped significantly from 61.7699 to 3.0866, indicating a limitation in data transmission capacity. The results of this study are important for improving the performance of communication systems using uniform FBG. Optical fibers with uniform FBG showed an increase in quality factor and a decrease in error compared to Gaussian FBG. In CWDM optical fibers with uniform FBG channels, the system performance also improved, with better quality factor and lower error compared to Gaussian FBG. The use of uniform FBG provides the best quality and lower BER compared to Gaussian FBG.

ACKNOWLEDGEMENT

The author would like to express their gratitude to LPPM Universitas Riau for funding this research with a mandatory research grant under contract number 16680/UN19.5.1.3/AL.04/2024.

REFERENCE

- Gong, C. & Zhang, X. (2019). Two-dimensional magnetic crystals and emergent heterostructure devices. *Science*, 363(6428).
- El-Hageen, H. M., Alatwi, A. M., & Rashed, A. N. Z. (2020). Silicon-germanium dioxide and aluminum indium gallium arsenide-based acoustic optic modulators. *Open engineering*, 10(1), 506-511.
- Fauzi, A. (2021). Perancangan konfigurasi FTTH jaringan akses fiber optik dengan optisystem dalam modul praktikum komunikasi optik. *Indonesian Journal of Applied Informatics*, 5(2), 146-154.
- El-Gammal, H. M., El-Badawy, E. S. A., Rizk, M. R., & Aly, M. H. (2020). A new hybrid FBG with a π -shift for temperature sensing in overhead high voltage transmission lines. *Optical and Quantum Electronics*, 52, 1-24.
- Harpawi, N., Putra, E. H. P. H., & Qory, R. R. (2017). Desain jaringan fiber optik menggunakan Optisystem untuk kawasan Kota Pekanbaru. *Jurnal Elementer*, 3(2), 21-30.
- Hidayah, F. N. & Haikal, H. (2022). Analisis pembebanan terhadap panjang gelombang cahaya berbasis sensor fiber Bragg grating (FBG). *Teknika*, 7(3), 116-122.
- Huang, L. J., Mao, X. T., Li, Y. Y., Liu, D. D., Fan, K. Q., Liu, R. B., Wu, T. T., Wang, H. L., Zhang, Y., Yang, B., Ye, C. Q., Zhong, J. Y., Chai, R. J., Cao, Q., & Jin, J. (2021). Multiomics analyses reveal a critical role of selenium in controlling T cell differentiation in Crohn's disease. *Immunity*, 54(8), 1728-1744.
- Ikhsan, R., Syahputra, R. F., Saktioto & Okfalisa. (2018). Performance control of semiconductor optical amplifier and fiber Raman amplifier in communication system. *2018 19th IEEE/ACIS*

- International Conference on Software Engineering, Artificial Intelligence, Networking and Parallel/Distributed Computing (SNPD)*, 32-36.
- Juwari, J., Jayadi, P., & Sussolaikah, K. (2022). Analisis redaman kabel fiber optic patchcord single core. *Jurikom*, 9(2), 202-210.
- Li, T., Shi, C., Tan, Y., Li, R., Zhou, Z., & Ren, H. (2016). A diaphragm type fiber Bragg grating vibration sensor based on transverse property of optical fiber with temperature compensation. *IEEE Sensors Journal*, 17(4), 1021-1029.
- Mnati, M. J., Chisab, R. F., Al-Rawi, A. M., Ali, A. H., & Van den Bossche, A. (2021). An open-source non-contact thermometer using low-cost electronic components. *HardwareX*, 9.
- Nor, S. R. M., Yusof, F., & Norrulashikin, S. M. (2021). Coherent mortality model in a state-space approach. *Sains Malaysiana*, 50(4), 1101-1111.
- Qiao, X., Shao, Z., Bao, W., & Rong, Q. (2017). Fiber Bragg grating sensors for the oil industry. *Sensors*, 17(3), 429.
- Tahhan, S. R., Ali, M. H., & Abass, A. K. (2019). Characteristics of dispersion compensation for 32 channels at 40 Gb/s under different techniques. *Journal of Optical Communications*, 41(1), 57-65.
- Saktioto, T., Ramadhan, K., Soerbakti, Y., Syahputra, R. F., Irawan, D., & Okfalisa, O. (2021). Apodization sensor performance for TOPAS fiber Bragg grating. *Telkonnika*, 19(6), 1982-1991.
- Skrzetuska, E. & Wojciechowski, J. (2020). Investigation of the impact of environmental parameters on breath frequency measurement by a textile sensor. *Sensors*, 20(4), 1179.
- Pertiwi, A. R., Saktioto, S., Widiyatmoko, B., & Hanto, D. Analysis of pressure distribution in cylindrical tube fluid flow using a fiber Bragg grating. *Indonesian Physics Communication*, 21(2), 109-114.
- Maulana, A. M., Ramadhan, K., & Irawan, D. (2023). Analysis of fluid flow in a cylindrical tube using fiber Bragg grating. *Science, Technology and Communication Journal*, 4(1), 17-22.
- Ramadhan, K., Irawan, D., & Yupapin, P. (2023). Core multi-layer dispersion on single-mode optical fiber. *Science, Technology and Communication Journal*, 3(3), 89-94.