

# Motor Control Center Breaker Modification Through On/Off Switch to Prevent Motor Failure \*

A. Rosyiddin<sup>1,\*</sup>, I. M. Arief<sup>2</sup>, N. H. Minanta<sup>1</sup>

<sup>1</sup>Department of Electrical Maintenance, PT. PLN Indonesia Power Pro POMU, Jakarta, Indonesia

<sup>2</sup>Department of Operation Planning and Controlling, PT. PLN Indonesia Power Pro POMU, Jakarta, Indonesia

\*E-mail: [ahmad.rosyiddin@indonesiapower.co.id](mailto:ahmad.rosyiddin@indonesiapower.co.id)

## Abstract

Motor Control Center (MCC) GT module, is a power breaker device that connects the voltage source to the load. MCC breaker rack-in and rack-out activities can be classified as *unsafe action* and *unsade condition*. Because there is a *possibility of explosion*. As it had happened several times in several places in the world. In 2021 there were 3 force derating and force outages which are caused by MCC motor breaker failures. That accident resulted 500,516.67 KWh loss or Rp 682,262,223,- (\$ 44,766). Therefore, modifications need to be made to 0.4kV MCC breaker by adding a selector for the order off blocker to minimize socket damage due to frequent rack-in-rack-out breakers activity. After installing the modification to all breakers in Priok POMU, there was no failures occurred. The frequency of rack-in-rack-out activities were reduced significantly and that is a good result for operation safety. This modification can also prevent Priok POMU from a potential loss and potentially increase net profit up to Rp 221,549,398,- (\$ 14,537).

**Keywords:** MCC breaker, motor, failure, outages, derating.

## Abstrak

Modul GT Motor Control Center (MCC), merupakan alat pemutus daya yang menghubungkan sumber tegangan dengan beban. Aktivitas *rack-in* dan *rack-out* pemutus MCC dapat diklasifikasikan sebagai tindakan tidak aman dan kondisi tidak aman. Karena ada kemungkinan meledak. Seperti yang pernah terjadi beberapa kali di beberapa tempat di dunia. Pada tahun 2021 terjadi 3 *force derating* dan *force outage* yang disebabkan oleh kegagalan pemutus motor MCC. Kecelakaan tersebut mengakibatkan kerugian sebesar 500.516,67 KWh atau Rp 682.262.223,- (\$44.766). Oleh karena itu, perlu dilakukan modifikasi pada breaker MCC 0.4kV dengan menambahkan selektor pada *order off blocker* untuk meminimalisir kerusakan soket akibat seringnya aktivitas breaker *rack-in-rack-out*. Setelah dilakukan modifikasi pada semua breaker di POMU Priok tidak terjadi kegagalan. Frekuensi aktivitas *rack-in-rack-out* berkurang secara signifikan dan itu merupakan hasil yang baik untuk keselamatan operasi. Modifikasi ini juga dapat menghindarkan POMU Priok dari potensi kerugian dan berpotensi meningkatkan laba bersih hingga Rp 221.549.398,- (\$14.537).

**Kata kunci:** Pemutus PKS, motor, kegagalan, pemadaman, penurunan daya.

---

\*Best presenter dalam Science Technology and Management (STeM) MeetUp, 22 November 2022 di Yogyakarta.

## 1. INTRODUCTION

The 0.4 kV low voltage breaker, commonly called the Motor Control Center (MCC) GT module, is a power breaker device that connects the voltage source to the load, usually to run the motors. To protect the load side of the MCC module, thermal overload relay and fuses are installed. The purpose of the protection system is to disconnect a circuit in case if there is an excessive current flow in the circuit, or in case if there is an electrical load that exceeds capacity. When the protection system doesn't work, the motor failures will happen.

In some cases, motor failures were caused by damaged winding, as domino effect from lost phase on breaker system, which mainly the root cause of this problem is fuse or MCC breaker socket. As a result, the equipment which needs motor as driving force will not work properly. Moreover if it happens to main equipment in power plant it will cause **derating state** or on top of that it will cause **force outages**. MCC breaker problem often occurs because the socket is broken. After further investigation, broken socket of MCC is caused by MCC breaker *rack-in* and *rack-out* activities. Those frequently happens when equipment test is needed. For example, in order to test the performance of pumps or motors we need to rack the MCC breaker out so the pump or motor can be ordered to operate manually. After doing the test, the MCC breaker has to be racked in, so it can be ordered to operate automatically or it can be operated by the sequence of operation step.

A study conducted by Thippana et al. showed that the Flexible AC transmission systems (FACTS) devices such as Thyristor control series capacitor (TCSC) and Static synchronous series compensator (SSSC) with designed control logic can be applied to limit the fault current located in LV distribution network. The study used low voltage switchgear (LVS) fed from motor control centre (MCC) switchgear through step down transformer of 11kV or 33kV /415V. The simulation and experimental analysis were carried out to observe the phenomenon that occurred.

Another study that reported by Durocher and Hussey indicated that the upgraded and modified the MCC can drastically reduce cost included the cable replacement, ground systems, and improved network communications using the modern technology. The same study discussed by Collins and Durocher is compared the existing MCC vs upgraded MCC. The results indicated that different aspect can be involved, i.e., digital transformation with the more complex task can be done with the wider business model also can be applied in the future. In addition, in a study conducted by Tremblay et al. is replacing old equipment with newer technology. The purpose of replacement is to improve operational reliability so that the potential for equipment to be out of service for a long time can be avoided.

Additionally a study conducted by Durocher et al. discusses the importance of updating parts of the circuit breaker to reduce significant risks to the equipment. Overall the study conducted describes changes in workplace operations and safety practices related to the installation.

In order to avoid that accident, modification is needed, so the frequency of rack-in-rack-out activities can be reduced or even eliminated. The aim of this study is to do the modification of MCC breaker to prevent the breakdown of the MCC breaker socket (motor failures) so the **power plant reliability will get better** and **unsafe condition can be eliminated**.

## 2. MATERIALS AND METHODS

To do this study, there are several steps needed. The following sub section are described the step-by-step materials and methods that used to solve the problems that occurred.

### A. Wiring Diagram

Wiring diagrams are used to find out the details of the relationship between each electrical component, usually for this circuit it is a simplification of a circuit, a description of the number and connection pictures. So it will be easy to find the problem and solve it. Wiring diagrams are divided into 2 types, namely power diagrams and control diagrams. The power diagram is a series of motor main voltage lines, where the current flow to the motor is determined by the condition of the contact children of the main contactor.

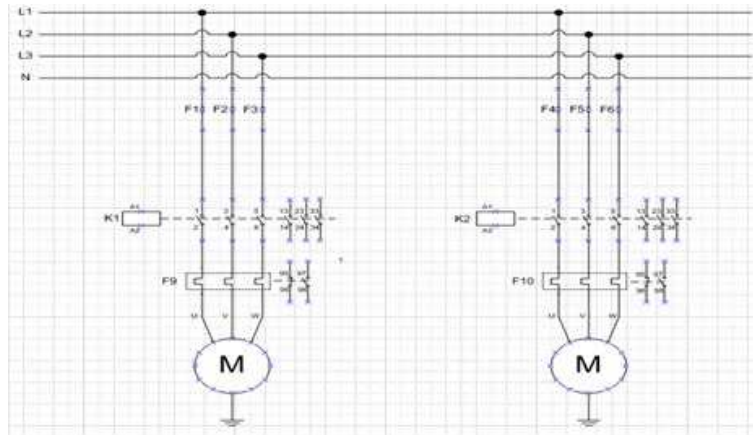

Figure 1. Power Network

While the control diagram, as shown in Figure 1, is a circuit used to disconnect or connect the flow of current to the motor through the main contactor contact child. The main contactor must be energized or get a supply voltage so that the contact changes conditions. The circuits include magnetic contactor current safety fuse / MCB (small), push button stop, push-button start: key-start key, etc., magnetic contactor auxiliary contacts NO-NC, NO-NC timer auxiliary contacts, Thermal Over Relay auxiliary contacts, and sign light.

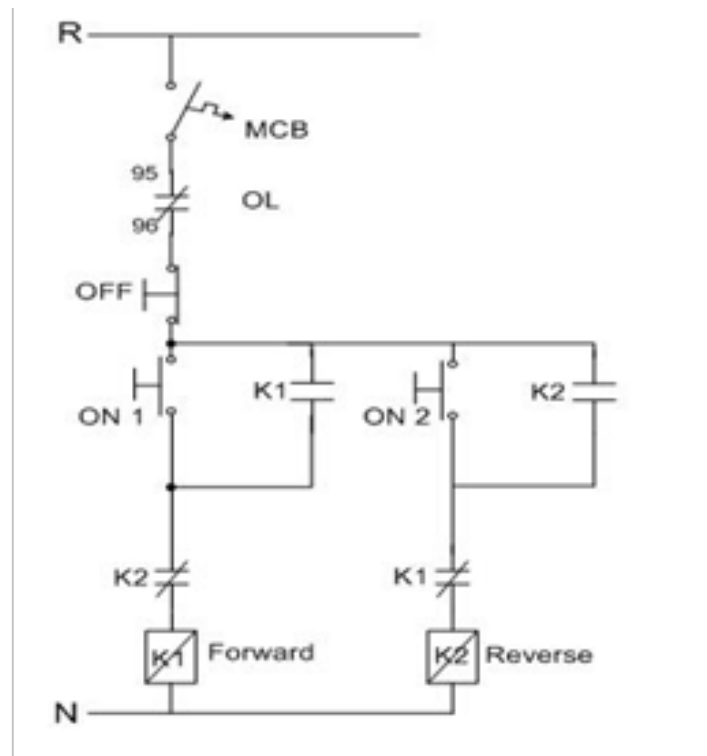

Figure 2. Control Networks

## B. Fuse

Fuse is a component that functions as a safety in electronic circuits and electrical devices. Fuse (fuse) basically consists of a short fine wire that will melt and break if it is energized by excessive electric current or the occurrence of a short circuit in an electrical/electronic equipment. With the break of the fuse, the excessive electric current cannot enter the electronic circuit so that it does not damage the components contained in the electronic circuit in question. Because the function of fuse is to protect electrical equipment from damage due to excessive electric current, fuse are also often referred as electrical safety.

## C. Miniatur Circuit Breaker (MCB)

MCB (Miniature Circuit Breaker) is a switch or electromechanical device that functions as a protection for electrical installation circuits from overcurrent. This overcurrent may be caused by several symptoms, such as:

short circuit and overload. MCB actually has the same function as a fuse, which will cut off the flow of electric current in the circuit when an overcurrent disturbance occurs. The difference is that when a disturbance occurs, the MCB will trip and when the circuit is normal, the MCB can be switched on again (reset) manually, while the fuse will be disconnected & cannot be used anymore.

#### D. Magnetic Contactor

A magnetic contactor is a switch that works on an electromagnetic basis used to open and connect an electrical circuit (load). The magnetic contactor works to change the Normally Open (NO) and Normally Close (NC) contacts. In the magnetic contactor there are two contacts, namely: the main contact and the auxiliary contact.

#### E. Thermal Overload Relay (TOR)

Thermal overload relay is a circuit safety device from overcurrent caused by a load that is too large by breaking the circuit when a current that exceeds the setting passes through it. Thermal overload serves to protect electrical circuits and electrical components from damage due to overload. Thermal overload protects the circuit in all three phases by using a bimetallic system. This thermal overload can be paired directly with the contactor or separately so it is very flexible for installation in the panel. The selection of the type of thermal overload is determined by the current rating/setting according to the nominal current of the circuit at full load and its trip class.

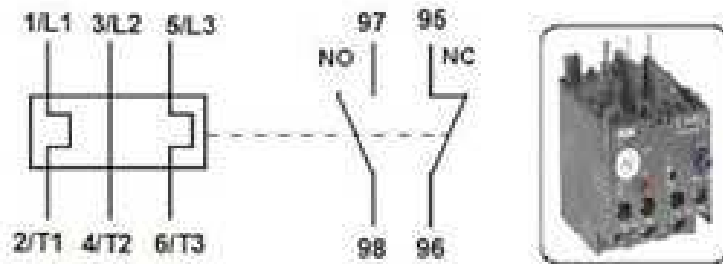

Figure 3. Thermal Overload Relay

#### F. Switch Selector

Switch selector is an electrical component that is outside the electrical panel that functions as a mode selector or change the direction of electric current that works by turning right or sending from the switch selector. The principle works when the switch selector is rotated to the right which was originally on the left, the current will flow towards the N/O or N/C contacts of the Right selector. The term selector chooses but in electrical components the selector serves to move electric current from the block contact to the other block contact.

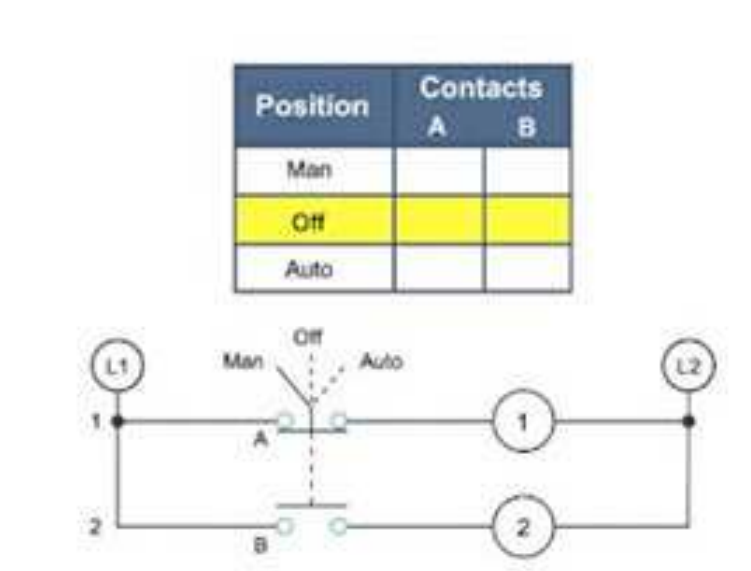

Figure 4. Switch Selector Structure

### 3. RESULT AND DISCUSSION

#### A. ON/OFF Switch Installation

In the work of installing switches for orders off, it is necessary to prepare some of the required materials. The materials and services needed in the installation of relay blocking are shown in table below :

Table 1. Material and Cost Needed

No	Material	Qty	Metric	Price/Unit	Total
1	Selector Switch	60	Pcs	Rp 45,000.00	Rp 2,700,000.00
2	NYYHY 1 x 0,75 mm Cable	180	Meter	Rp 10,000.00	Rp 1,800,000.00
3	Skun Kabel	120	Pcs	Rp 30,000.00	Rp 3,600,000.00
4	Man Power Hour	120		Rp 50,000.00	Rp 6,000,000.00
	Cost				Rp 14,100,000.00
	VAT 10%				Rp 15,510,000.00

In the installation of the order off switch for wiring, it is still in accordance with the existing wiring on the MCC Module GT breaker. The installation of this switch will use the Normally Closed (NC) contact in its normal condition and the Normally Open (NO) contact will be used when the order-off blocking process is carried out. Figure 5 shows the existing wiring diagram

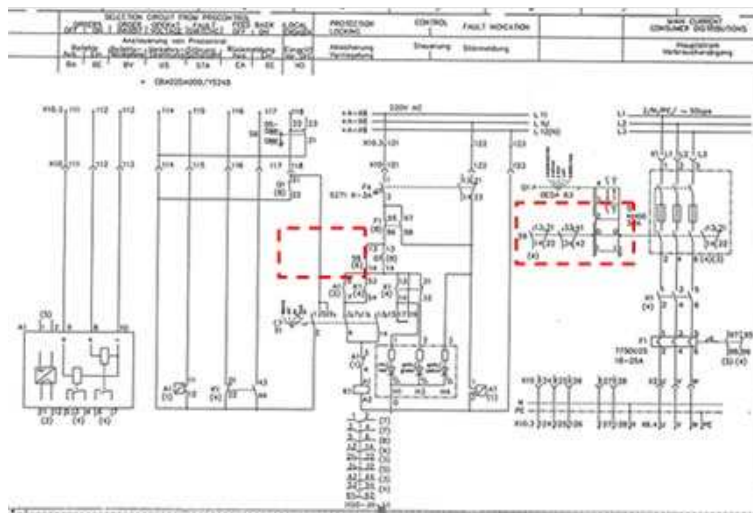

Figure 5. Existing Wiring Diagram

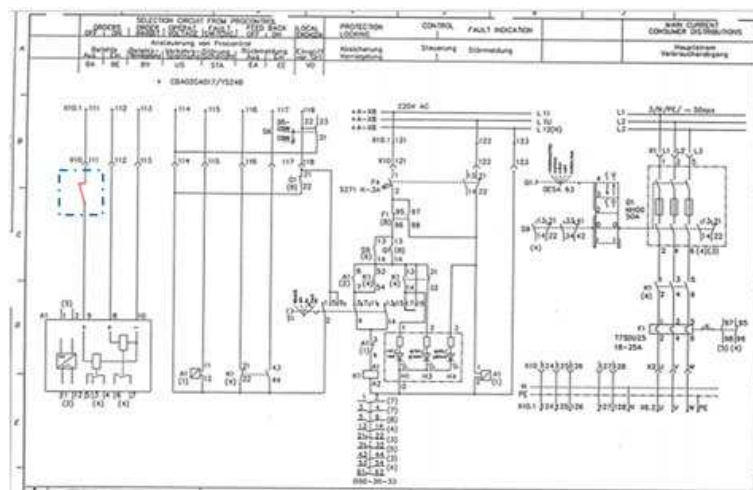

Figure 6. On/Off Switch Wiring Modification

Based on the study of the existing control wiring, redrawing is carried out by adding switches for order off, which is expected to reduce damage to the blade tongue of the MCC Module GT socket breaker. Therefore, the

potential for breakdown when the motor is operating which causes unit derating can be eliminated. Production Losses caused by breaker failures are shown in Table 2.

Table 2. Production Losses Caused by Breaker Failures in 2021

No	Unit	Loss (kWh)
1	GT 1.2	51,600
2	ST 1.4	126,000
3	GT 2.2	322,916.67



Figure 7. On/Off Switch Modification Result

Currently, additional order off switches have been installed and used in unit operation (shown in figure 7). For example, the condition when the unit starts up, the Generator Cooling Water Pump (GCWP) motor often changes over (CO) between pump no 1 to pump no 2. When the CO process continues, the motor will experience continuous inrush currents which will cause one of which is a broken fuse breaker and can cause a Lost Phase so that the motor will only receive 2 phases or 1 phase depending on the number of broken fuses. So, the installation of this modification can prevent similar accidents occur.

After the installation of this modification, there is no *force outages* or *force derating* occurs caused by breaker failures, which means the modification is proven to make a better result.

**B. Non Financial Benefits**

According to this study, there are non financial benefit which is shown in table 3

Table 3. Priok POMU Key Performance Indicators

No	Key Performance Indicator	Unit	Weight	Semester 2 Goals
I	Costumer PERSPETIVE		4	
1.1	Costumer Satisfaction Value (Existing and O&M Services)	%	4	86.5
II	Product and Process Effectiveness			
2.1	EFOR (Equivalent Force Outage Rate) PLTGU Block 1-2 and PLTD Senayan	%	5	1.05

By modifying the selector breaker, the EFOR value is based on the achievement in 2021, the EFOR can be reduced by 0.01% which, when linked to the value in the Management Contract, has a weighted value of ± 0.05 points. Other non-financial benefit from this modification that is fundamental, is safety aspect. Because a broken breaker socket will cause explosion effect if it is left like that. The other non-financial benefits are increasing GT operating system reliability, increasing customer satisfaction and maintain JAMALI'S electricity supply.

**C. Financial Benefits**

Based on this study, financial benefit which is obtained, is shown in table 4

Table 4. Financial Benefits Calculation

	Description
Income	Rp 682,262,223,- kWh Losses in 2021 (Rp)

Cost	Rp 460,712,825,-	Potential Additional Fuel Gas Cost and Component Cost
Net Profit	Rp 221,549,398,-	Potential Net Profit

According to table 4, the modification could save up to Rp 682,262,223,- as kWh losses in 2021 is converted to potential income, and potential net profit obtained is Rp Rp 221,549,398,-.

#### 4. ACKNOWLEDGMENT

The authors want to say gratitude to Indonesia Power Priok POMU Jakarta, Indonesia for the support and funding to fulfill the present study.

#### 5. REFERENCES

- C. Collins, L. B. Farr and D. B. Durocher., (2016). "Process modernization upgrade: Selecting and installing a new medium-voltage motor control center," IEEE Industry Applications Society Annual Meeting, Portland, OR, USA, 2016, pp. 1-9, doi: 10.1109/IAS.2016.7731922.
- D. B. Durocher and M. R. Hussey. (2019). "Vintage Low-Voltage Motor Control Centers - Replace or Upgrade?," 2019 IEEE Industry Applications Society Annual Meeting, Baltimore, MD, USA. pp. 1-9, doi: 10.1109/IAS.2019.8912377.
- D. B. Durocher, M. Koepke and D. Fisher. (2019). "Advancing Workplace Safety Through Vintage Equipment Upgrades," 2019 IEEE IAS Electrical Safety Workshop (ESW), Jacksonville, FL, USA, 2019, pp. 1-5, doi: 10.1109/ESW41045.2019.9024722.
- E. Tremblay, A. Kachurovski, D. Leschert and K. Busby. (2019). "Protective Relay Upgrade Utilizing Real-Time Simulator Technology," 2019 IEEE Petroleum and Chemical Industry Committee Conference (PCIC), Vancouver, BC, Canada. pp. 167-178, doi: 10.1109/PCIC30934.2019.9074529.
- V. C. Thippana, A. M. Parimi, and C. Karri. (2021). Series facts controllers in industrial low voltage electrical distribution networks for reducing fault current levels. *Int. J. Power Electron. Drive Syst.*, vol. 12, no. 4, pp. 1953–1965, 2021, doi: 10.11591/ijpeds.v12.i4.pp1953-1965.