

The Design of the Measuring Tool of Clamping Force on E Clip Rail Fastening Systems

Rusman Prihatanto^{1*}, Adya Aghastya¹, Dimas Faisal Maulana¹, and Risma Fauziah Rahmawati¹, Afif Navir Refani²

¹Department of Technology on Construction and Railways, Indonesian Railways Polytechnic Madiun, Jl. Manis Raya, Madiun City, INDONESIA

²Graduate School of Engineering Kobe University
1-1 Rokkodaicho, Nada Ward, Kobe, Hyogo 657-0013, JAPAN

Article Info

Article history:

Received 1 February, 2023

Revised 2 March, 2023

Accepted 30 March, 2023

Keywords:

Clamping force,
E-Clip,
Fastening Systems,
Load Cell,
Solidworks

ABSTRACT

The rail fastening system is a core component to fastening a rail on the railway sleeper to make it strong and solid. The position of the railway sleeper probably could move by the effect of the dynamic movement of railway wheels on the railroad. Elastic fastening which has a clamping force of 900-1100 kgf (kilogram-force) for each clip is one of the elastic fastening types. The deflection of Pandrol E-Clip is between 11,5 – 14 mm with the clamping force as 0,6 – 1,1 ton. The degradation of clamping force on fastening systems inevitably occurs by its use and regular railways operation. This study aims to create a strong, solid, and easy-to-operate measuring tool for clamping force on type E clip fastening systems. The design of the measuring tool of clamping force on type E clip fastening uses Solidworks software. After testing the measuring tool of clamping force on type E clip fastening systems, it shows that it is solid, countable and there is no form-change and damage on it. The design of that measuring tool can be effectively operated by two officers and it has 850 mm in height, and 270 mm in width, and its weight including load cell and indicator reaches 17,83 kg. The function test on the measuring tool of the E-Clip fastening shows an average score of 1589,40 – 1682,50 kgf of clamping force. The result of clamping force measurement on the fastening by using a designed measuring tool is bigger than the need of clamping force of installed fastening namely 915,71 kgf.

*Corresponding Author:

Rusman Prihatanto

Department of Technology on Construction and Railways, Indonesian Railways Polytechnic Madiun,
Jl. Manis Raya, Madiun City, Indonesia

Email: rusman@ppi.ac.id

1. INTRODUCTION

The railroad is solid construction made of steel, concrete, and other materials constructions which are positioned on the surface, underground, and above hanging together with its components that have the function to direct the train running [1]. The structure of a railroad consists of some components they are road body, sub-ballast, ballast, sleeper, fastening systems, rail, and switch rail. The rail fastening system firmly connects the rails to the sleepers and its performance affects the structural safety of rails, ride safety and quality, and railway noise. The modern rail fastening system deviates from simply clamping the rail and sleepers together by using tension clamps to resist the tension, compression, and rotation of the rails that derive from the train load or track alignment [2]. Fastening systems plays a role to fasten rail on the railway sleeper to make sure that the rail is solid and strong. The position of the rail potentially could move as a consequence of the dynamic movements of railway wheels on the railroad. The dynamic movement of railway wheels causes a huge lateral force on the rail condition. Therefore, a solid and strong fastening systems is significantly needed to reduce this kind of lateral force [3], [4]. The behavior of the rail fastening system can be affected by various factors, such as the track condition, track alignment, and initial construction quality. Due to insufficient consideration of these factors, tension clamps often fail earlier than the service life guaranteed by the manufacturer [5-7]. The fastening systems tool of stiff and elastic. The elastic one has a clamping force of 900 – 1100 kgf for each clip fastener [8], [9]. Deflection occurs on Pandrol E-Clip between 11,5 – 14 mm with clamping strength 0,6 – 1,1 ton [10]. The routine use and regular operation of the railway itself certainly reduce the clamping force of fastening systems. Clamping force of rail fastener is an essential parameter relevant to the safety of railway track structure but also is hard to test on site. Though field testing of clamping force in the existing line has not done before, some laboratory tests have performed by manufacturers and other researchers. In Europe, experimentalists measure clamping force of fastening system according to the standard of EN 13146-7-2002 which is applicable to complete fastening systems assembly [11]. Inspection and maintenance of railway components is an obligation to determine their condition and other supporter components such as railroad tracks, railway stations, and railway operating facilities. Inspection on railroad tracks comprises periodic and non-periodic inspections. Periodic inspection consists of daily and scheduled inspections. Moreover, an inspection of the fastening system is conducted visually by using a clamping force meter measurer [12]. In Japan, rail fastenings are required to be checked for their performance by the static loading test at a laboratory (hereafter, laboratory test) [13]

In fact, checking the fastening systems by using a clamping force meter to discover how strong the clamping force of the installed fastening is not done yet due to a lack of tools. The inspection of the fastening systems is only carried out visually by hammer to check whether the fastening clip is slack or not. When the clip fastener is slack, it is replaced by the new one.

To design the measuring tool of fastening clamp force, the writers use Solidworks software. This kind of software is commonly utilized to design 3D models with 3 appearances in Solidworks, they are; (1) part to draw a model, (2) Assembly is used to combine previous parts which are drawn in the part appearance, (3) drawing; to draw or to represent the model of a part or the model of assembly where they are designed to be a ready printed blueprint[14], [15].

It is in line with the statement from [16] namely due to reaching the goal of an ideal design, it is necessary to consider some aspects for instance working principles, test method, and available design. The criterion of design in the making of a measuring tool of clamp force on fastening systems ought to synchronize to the function of the fastening itself, characteristics of fastening placements, fastening types, and specific techniques of fastening. In consequence, the process of designing the measurement tool of clamp force on fastening systems must meet some criteria, they are; strong, solid, easily operated, ergonomic, and aesthetic. Strong here means that the clamping force measurement tool must have a strong design and can pull the clip fastener suitable with the determined deflection. The criterion of easy to operate means that the tool will be designed and can be operated by anyone without requiring a particular skill. The criterion of ergonomics means that the convenience of the users to do the job by using the clamping force measurement tool of fastening systems is very important. The last, criterion of aesthetics, means that the tool must be designed to be attractive and easily recognizable by the officers/workers.

This study is aimed to make a strong and easily operated measurement tool of clamping force on the E-Clip fastening systems with the specification it has a big clamping force of 900 – 1100 kgf for each clip. In addition, the measurement tool will be designed can be operated in the field by a maximum of 2 officers. Moreover, it is easily moveable to fit the limited window time on inspecting the fastening clamping force.

2. RESEARCH METHOD

2.1 Data Collection Method

The data in this study consists of primary and secondary data. Primary data consists of a field survey to obtain the fastening systems data which are used and data about the specification of tool components used in the study to meet the relevant needs. Furthermore, secondary data include the technical data of E-Clip fastening systems and technical data of railroad tracks.

2.2 Data Analysis Method

Data analysis is done by establishing suitable material, design, and tool components to make a measurement tool of clamp force on the fastening systems. The next step is determining the specification of tool components. Afterward, make design alternatives. The making of the tool at the workshop is processed after the design alternative is selected. In the end, administering the test on the measurement tool of clamp force on the fastening systems, to decide whether it meets the determined criteria, or on the contrary, it unexpectedly does not meet the criteria. The tool test is done on the railroad tracks Indonesian Railway Polytechnic, in Madiun. The sample of the fastening systems is measured randomly by using the measurement tool of clamp force on the fastening systems. It is conducted to aim for all populations to have the same chance to be chosen as a sample [17]. Here below is a diagram containing steps in the research as yielded in Figure 1.

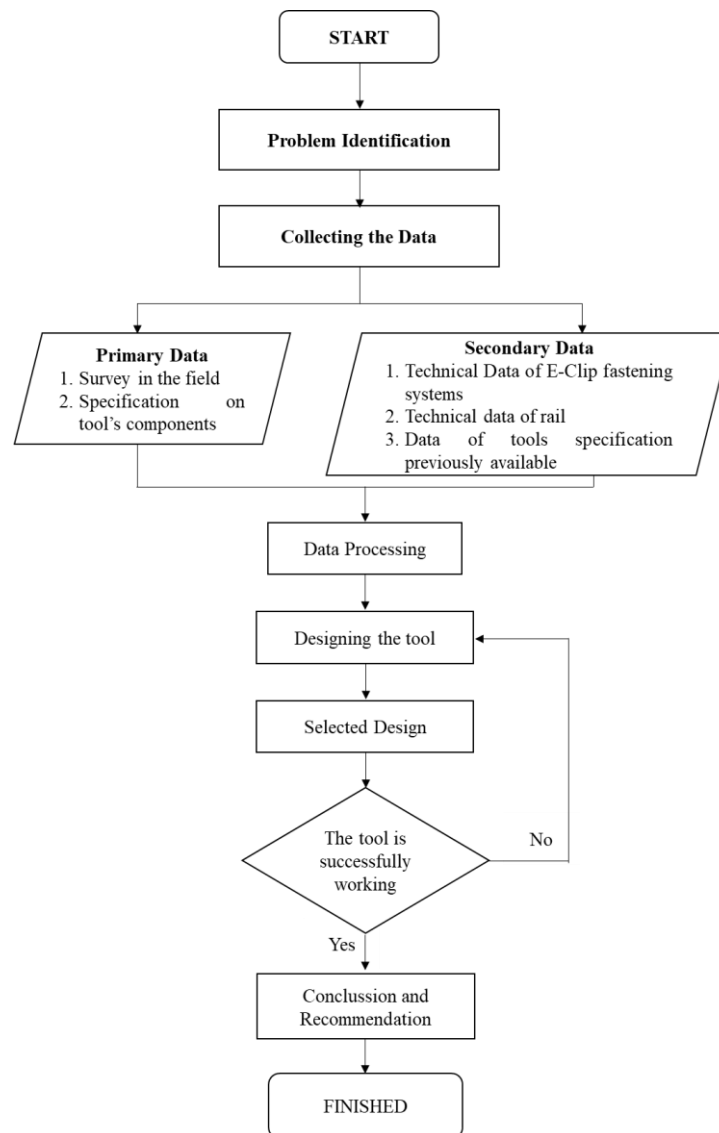

Figure 1. Diagram of Research Steps

3. RESULTS AND DISCUSSION

3.1 Result of Design

This study aims to create a measurement tool for the clamping force of fastening systems that fits the criteria; strong, easy to operate, ergonomics and aesthetics. To obtain the best result of design, the researchers make 4 (four) design alternatives. The selected design alternative is followed up by making a suitable tool based on the planned design. The following is the design alternative and weighting for each criterion.

Table 1. Scoring on each design alternative

Criteria	Weighting (%)	Alternative 1		Alternative 2		Alternative 3		Alternative 4	
		Score	Value	Score	Value	Score	Value	Score	Value
Strong	40	70	28	70	28	80	32	80	32
Easily operated	25	70	17.5	80	20	70	17.5	80	20
Ergonomics	25	70	17.5	70	17.5	80	20	80	20
Aesthetics	10	20	2	10	1	50	5	50	5
Total	100		65		66.5		74.5		77

Based on table 1, the alternative design number 4 is selected due to the highest score 77. Subsequently, the design alternative number 4 is followed up to the next step namely making the measurement tool based on the alternative design 4 as shown in Figure 2. There are some main components to construct the selected design namely framework, clamper, and measuring tool. Two options of measuring tools can be used namely load cell or tension meter. To test the strength of the design alternative, it is given the same burden as 3.000 kgf. Afterward, design alternative 4 is the strongest design to hold the given burden. The result of the giving burden simulation is shown in Figure 3.

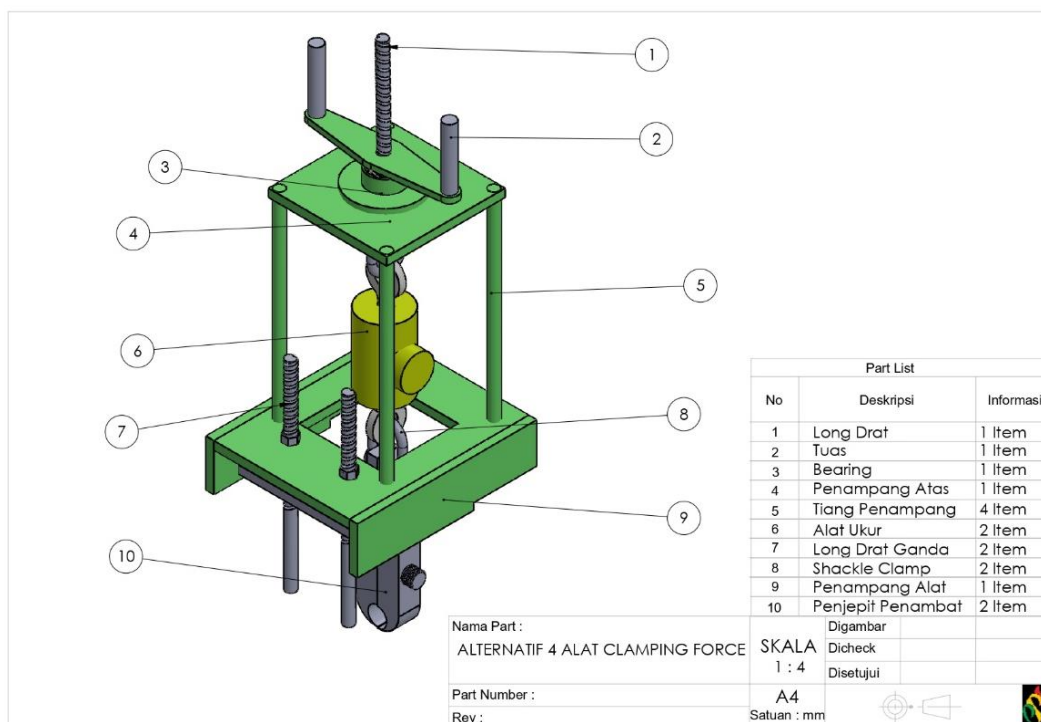

Figure 2. Selected design

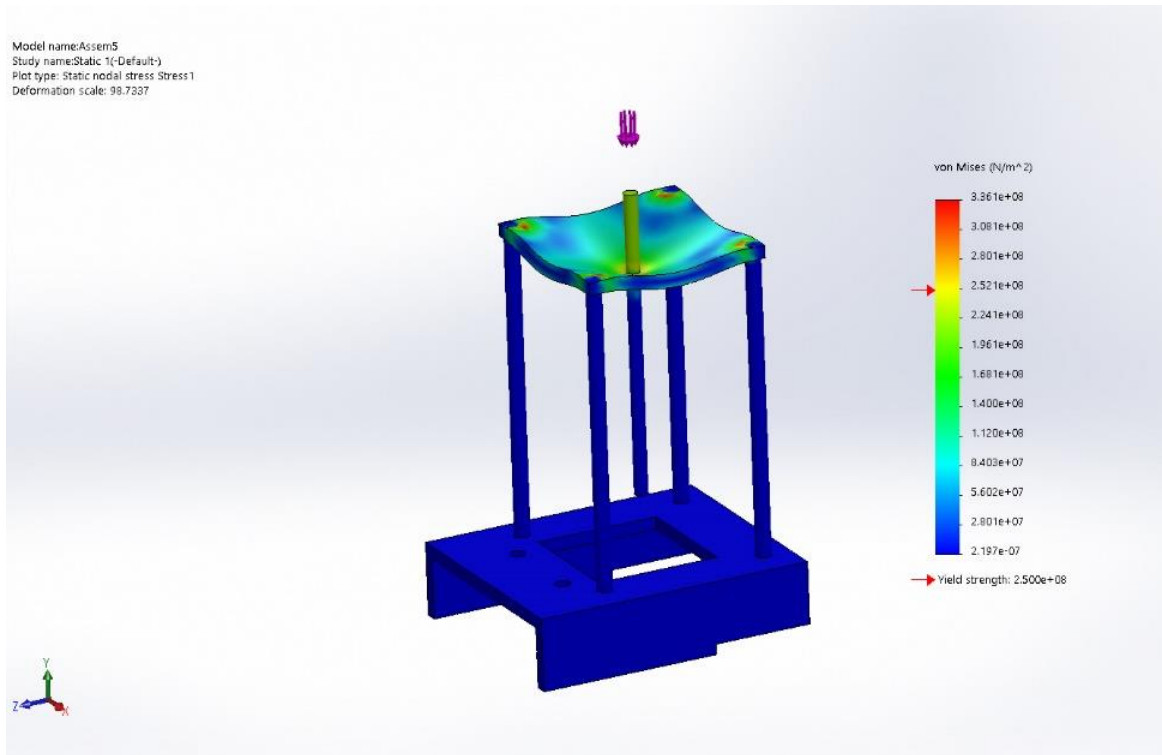

Figure 3. Burden simulation

Figure 3 shows that the modeled and planned design can withstand the given burden of 3.000 kgf without any damage or destruction. Thereupon, that design is finally processed into making the tool.

3.2 Making the Tool

The making tool is divided into 3 main components, namely part of the framework, part of clamping, and part of the measurement tool. In the part of the frame, it requires solid material due to withholding a maximum burden of up to 3.000 kgf. In the part of clamping, it must have the ability to clamp type E-Clip fastening systems. Lastly, in the part of measurement tool, it can use two options whether loadcell or tension meter. The process of making the tool is conducted at the workshop at the Indonesian Railway Polytechnic Madiun. Iron material is chosen for frame and clamping by reason it is easy to find in the market and its price is more affordable than any other material such as aluminum. The iron used in this study has quality ASTM A36. Technical specifications from the iron used to make the tool are drawn in table 2 below.

Table 2. Specification of steel with quality ASTM A36

Properties	Specification
<i>Tensile Strength, Ultimate</i>	400 – 550 MPa
<i>Tensile Strength, Yield</i>	250 MPa
<i>Modulus of Elasticity</i>	200 GPa
<i>Bulk Modulus</i>	140 GPa
<i>Poissons Ratio</i>	0,260
<i>Shear Modulus</i>	79,3 GPa
<i>Thermal conductivity</i>	25 W/m-K
<i>Specific heat</i>	460 J/kg-K

The process of making the parts of the framework and clamping tool is presented in Figure 4 and Figure 5.



Figure 4. Process of framework making



Figure 5. Process of Making the clamper

After the process of making the tool, a measurement tool is invented as presented in Figure 6 with detailed specifications as follows:

Table 4 Tool Specification

Ability:	Able to lift fastening systems with range 0,1 mm – 1 mm with clamping force 0-1.600 kgf.
Maximum height of tool	850 mm
Width of tool	270 mm
Plat thickness for cross section	12 mm
Plat thickness to withhold the long drat	5 mm
Capacity	3000 kgf
Tool's weight (includes load cell and indicator)	17,83 kg



Figure 6. Result of Design and Tool Making

3.3 Function Test on Tool

The next step after making the tool is testing the tool function on the rail fastening systems. The test is conducted on the railroad track of the Indonesian Railways Polytechnic, Madiun. In the phase of assembly and test of the tool, the function is yielded as in Figure 7.

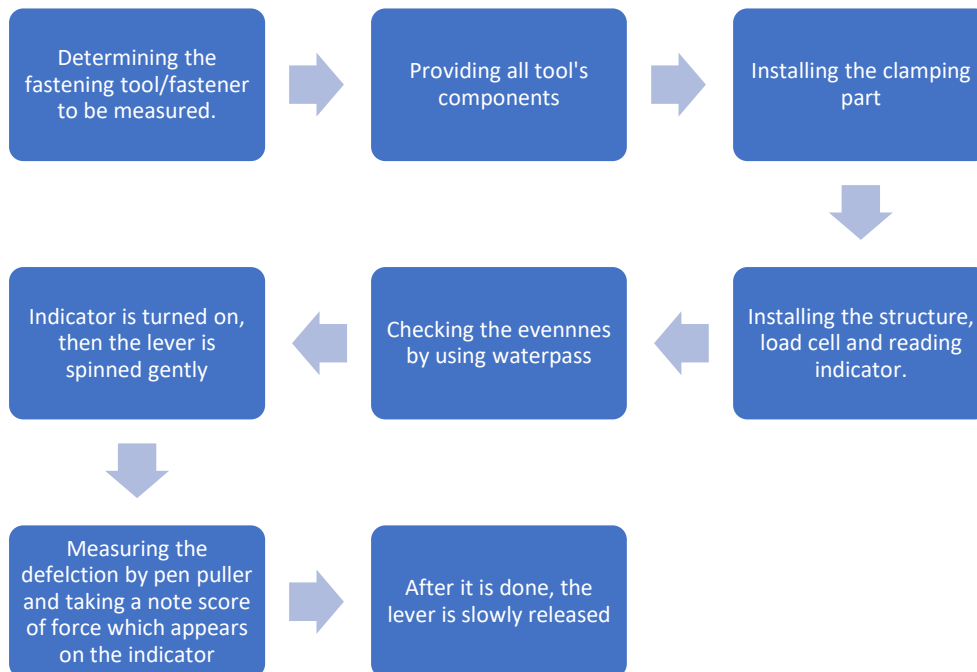

Figure 7. Phases of assembly and test of function on the tool

The test is done randomly on the 10 (ten) E-Clip fastening systems and the results are yielded in table 3 as follows. According to [18] measurement of the value of the spring deformation in the device body when the terminal is raised above the rail sole by a value of 0.10-0.15 mm.

Table 4. Result of Test on Measurement Tool of Fastening Clamp force

No. Measurement	Deflection (mm)										Average (kgf)
	0.1	0.2	0.3	0.4	0.5	0.6	0.7	0.8	0.9	1.0	
1	1488	1508	1520	1531	1573	1688	1727	1735	1746	1757	1627.30
2	1487	1507	1527	1552	1579	1609	1639	1669	1863	1893	1632.50
3	1517	1547	1577	1608	1639	1671	1703	1830	1845	1888	1682.50
4	1397	1427	1462	1505	1555	1605	1657	1709	1762	1815	1589.40
5	1391	1431	1485	1511	1552	1623	1654	1707	1750	1815	1591.90
6	1518	1548	1578	1608	1638	1668	1703	1738	1773	1808	1658.00
7	1537	1557	1582	1607	1637	1667	1699	1731	1764	1797	1657.80
8	1501	1531	1561	1593	1625	1658	1691	1721	1751	1783	1641.50
9	1552	1569	1586	1590	1598	1613	1624	1634	1646	1688	1610.00
10	1496	1521	1546	1573	1600	1630	1663	1696	1729	1762	1621.60

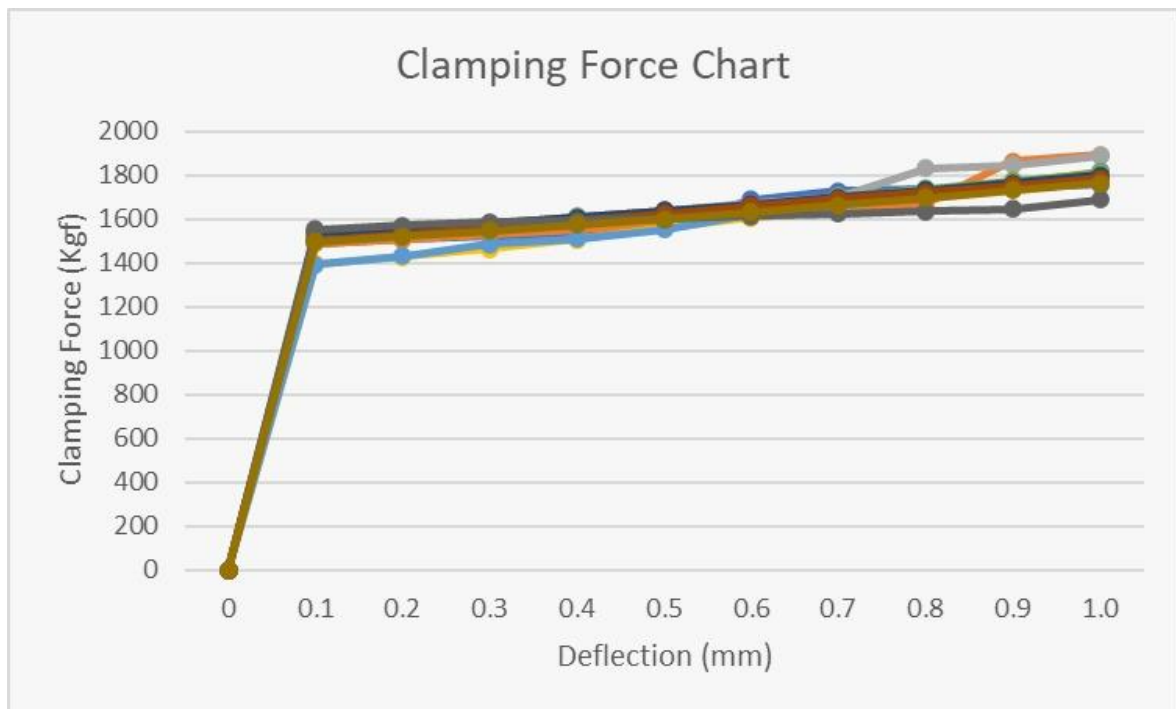

Figure 8. Graphic Shows Result of Test on Measurement Tool of Fastening Clamping Force

3.4 The Need for Fastening Clamping Force

According to [19], after the clamping force is tested, the clamping force generated by the elastic fastening systems is 750 kgf up to 1.300 kgf. Before testing it, we need to know how much the need of clamping force of a fastening systems to clamp a rail in the order it does not move by using the following formula:

$$H = M \times a \tag{1}$$

Where:

$a = 0.0478 \text{ g m/det}^2$ (requirements of convenience, PD 10)

$g = 9.81 \text{ kg m/det}^2$

$M = 18.000 \text{ kg}$ (axle load)

Based on the formula above, then:

$$\begin{aligned} H &= M \times a \\ &= 18000 \times 0.0478 \times 9.81 \\ &= 8440 \text{ kg m/det}^2 \\ &= 860.4 \text{ kgf} \end{aligned}$$

For rail R54 type

$$\begin{aligned} h &= 159 \text{ mm} \\ b &= 140 \text{ mm} \\ H(h-10) &= F(110-x) + (x) \\ F &= \frac{H(h-10)}{b} \\ F &= \frac{860.4(159-10)}{140} \\ F &= 915.71 \text{ kgf (Needed clamping force)} \end{aligned}$$

From the testing of the tool, it shows that the average score of clamping force from 10 times of testing the tool is bigger than the clamping force needed namely 915,71 kgf. This shows that the measurement tool has good performance to measure the clamping force of E-Clip fastening systems. In addition, there is no damage or destruction from the measurement tool to be tested.

4. CONCLUSION

Based on the analysis result, it concludes that the measurement tool of clamping force on the fastening systems has good performance and is positively proven during being tested. The result shows that the measurement tool is strong, solid, not damaged, and not transforming into a different form. The fixed design has dimensions of the tool's height (850 mm), the width of the tool (270 m), and the total weight including load cell and indicator (17,83 kg), and it is easy to be operated by two officers/workers. The function test on the tool on fastening systems shows E-Clip generates homogeneity data with the average score of clamping force fastening systems is around 1589,40 – 1682,50 kgf. The result of the measurement of clamping force on the fastening systems by using the designed measurement tool is bigger than the need of regular clamping force of installed fastening systems namely 915,71 kgf.

REFERENCES

- [1] Undang-Undang Nomor 23 Tahun 2007 Tentang Perkeretaapian. Jakarta, 2007.
- [2] Ji-Hyon Kim, Yeun-Chul Park, Mancheol Kim and Hyoung-Bo Sim, "A Fatigue Reliability Assessment for Tension Clamps Based on Filed Measurements Data", *Appl. Sci.* 2022, 12, 624. <https://doi.org/10.3390/app12020624>
- [3] Sri Atmaja P. Rosyidi Ph. D., *Rekayasa Jalan Kereta Api : Tinjauan Struktur Jalan Rel*, vol. Cetakan 1. Yogyakarta: Lembaga Penelitian, Publikasi dan Pengabdian Masyarakat Universitas Muhammadiyah Yogyakarta (LP3M UMY), 2015.
- [4] Warsiti, Kusdiono, Risman, H. T. Herarki, and M. I. Alif, "Analisis Kekuatan Jepit Penambat E-Clip Terhadap Perilaku Panas Pada Saat Pemasangan Pada Rel," *Jurnal Bangun Rekaprima*, Vol.05, no. 2, Nov. 2019.
- [5] Baik, C.-H.; Joo, B.-G.; Choi, J.-Y.; Park, Y.-G. The parametric study on the performance characteristics of elastic rail fastening system on the sharp curved track. *J. Conf. Annu. Meet. Korean Soc. Railw.* 2011, 14, 2163–2173
- [6] DB Netz AG. Technical notification concerning the body of permanent way technology regulations. In *Requirements Catalog for the Construction of the Permanent Way*, 4th ed.; DB Netz AG: Frankfurt, Germany, 2002
- [7] Park, Y.C.; An, C.; Sim, H.-B.; Kim, M.; Hong, J.-K. Failure Analysis of Fatigue Cracking in the Tension Clamp of a Rail Fastening System. *Int. J. Steel Struct.* 2019, 19, 1570–1577
- [8] Peraturan Menteri Perhubungan Nomor 60 Tahun 2012 Tentang Persyaratan Teknis Jalur Kereta Api. Jakarta, 2012.

- [9] Hermanto Dwiatmoko, *Pengujian Jalur dan Bangunan Kereta Api*. Jakarta: Prenada Media, 2016.
- [10] Danang Parikesit Prof. Dr. Ir. et al., *Jalan Rel*, vol. Cetakan Pertama. Surabaya: Scopindo Media Pustaka, 2021.
- [11] Q.T. Li, Y. Luo. and Y. Liu, “Estimating Clamping Force of Rail Fastener System by Experimental and Numerical Methods”, *Transportation Research Procedia* 25 (2017) pp. 443 – 450, July 2016
- [12] Peraturan Menteri Perhubungan Nomor 31 Tahun 2011 Tentang Standard dan Tata Cara Pemeriksaan Prasarana Perkeretaapian. Jakarta, 2011.
- [13] Tamagawa, Shingo, “Determination of Load Test Condition For Rail Fastening of A Floating Slab Track”, *International Journal of Computational Methods and Experimental Measurements* 9 (1):14-27, March 2021.
- [14] Djuhana, Ahmad Dwi Yulianto, and Mulyadi, “Plate Mold dengan Software Simulasi (Solidworks 3D),” *Journal of Technical Engineering: Piston*, Vol.3, no. 2, pp. 6–16, 2020.
- [15] Dadang Sanjaya Atmaja and Henry Widya Prasetya, “Perancangan Dan Pembuatan Prototype Alat Pemasang Dan Pelepas E-Clip Hidrolis Pada Perawatan Jalan Rel,” *Jurnal Perkeretaapian Indonesia*, pp. 22–31, Nov. 2021.
- [16] Tjokro Hadi, Sugiharto, Supriyo, Sutarno, and Sudarmono, “Rancang Bangun Komponen Pendorong Alat Pasang Pendrol Untuk Uji Penambat Rel,” *Jurnal Bangun Rekaprima*, Vol.04, no. 2, Oct. 2018.
- [17] Tedjo N. Reksoatmodjo, *Statistika Teknik*. Bandung: PT. Refika Aditama, 2009.
- [18] Khalfin Gali-Askar Rustamovich, “Clamping Force Intermediate Fastener and Their Determination”, *JournalNX-A Multidisciplinary Peer Reviewed Journal*, Vol 7, No. 5, May 2021.
- [19] Badan Standardisasi Nasional, SNI 11-3677-1995 tentang Penjepit Elastik Rel Kereta Api. 1995.