

## Analysis of the strength of the frame construction on the nyamplung bean peeling machine using the finite element method

Asep Dharmanto\*, Angger Haris Muzakki, Hilman Sholih, Aswin Domodite

\*Universitas Muhammadiyah Cileungsi, Cileungsi, Bogor, Jawa Barat, Indonesia, Jl. Anggrek, No. 25, Perum PTSC, Cileungsi, Bogor, Jawa Barat, Indonesia

\*✉ [adharmanto@gmail.com](mailto:adharmanto@gmail.com)

Submitted: 14/01/2024

Revised: 13/07/2024

Accepted: 21/07/2024

### ABSTRACT

The frame of the nyamplung bean peeling machine is a very important component in this design, the frame functions as a fulcrum for the mechanical and electrical components. The problem that occurred during observations was that when testing the nyamplung bean peeling machine at maximum rotation, the frame experienced vibrations. The aim of this research is to determine the stress distribution and deflection resulting from static loading on the frame of the Nyamplung bean peeling machine and to compare hollow tube materials with angle iron, which of these two types of material is more efficient. The framework structure was designed and analyzed using Solidwork 2021 software. There are several tests used, but most often the computational method is used using the Finite Element Method (FEM). In frame 1 calculations using housing and crusher loading of 50kg. The results of the simulation obtained a bending strength of 18 N/mm<sup>2</sup>, while manual calculations obtained a result of 19.94 N/mm<sup>2</sup>. Permissible stress in ASTM A36 material 160 N/mm<sup>2</sup>. The displacement in manual calculations was found to be 0.120 mm, whereas using simulation it was 0.077 mm. In frame 2 the results obtained from manual calculations were with a bending stress of 13.84 N/mm<sup>2</sup>. With simulation, the results obtained were 13 N/mm<sup>2</sup>, and the displacement in manual calculations was obtained at 0.117 mm, whereas using simulation it was 0.08 mm.

**Keywords:** Framework, FEM, nyamplung seeds

### 1. INTRODUCTION

In the current era of development, the world energy crisis, which is marked by soaring oil prices, has encouraged the world's population to shift their energy sources to renewable energy which is more environmentally friendly and renewable, one form of energy is biodiesel [1]. Biodiesel itself is oil from plants that are transformed into diesel oil for vehicles with diesel engines, one of the raw materials for biodiesel is nyamplung seeds [2].

The frame of the nyamplung bean peeling machine is a very important component in this design, the frame functions as a fulcrum for the mechanical and electrical components [3]. The problem that occurred during observations was that when testing the nyamplung bean peeling machine at maximum rotation, the frame experienced vibrations [4]. With this, the frame must have properties that are strong, light, and resistant to vibrations and shocks received from the load of each machine component [5]. Loading on the frame will affect the occurrence of deflection in frame construction, making it prone to cracking and even breaking [6][7]. The frame is a very important part of the nyamplung bean peeling machine, so when designing a frame it must be taken into account carefully and minimize failures in the frame [8]. Therefore, the safety factor of this frame is of particular concern. Many testing methods have been carried out to obtain frame design results so that they can meet safety standards [9].

Based on research carried out, the frame design for the nyamplung bean peeling machine was designed using two different types of materials as an initial comparison before entering the fabrication



process [10][11]. The materials used for comparison are hollow tubes and angel iron [12][13]. It is hoped that by comparing the two types of materials, the resulting frame design will be more efficient in terms of price and strength of the frame itself [14].

The type of testing used in this design is using a computational method using the element method or FEA (Finite element analysis) [15]. The finite element analysis method is a numerical solution method that uses an approach by dividing (discretizing) the object being analyzed into finite and interrelated elements. FEA itself is widely used in problems in the world of engineering, as a tool for analyzing structural strength, corrosion, heat transfer, and fluid flow [16]. This research aims to analyze the strength of the Nyamplung bean peeling machine frame construction.

## 2. METHOD

Simulation flow diagram using FEM: To determine the construction strength of the frame of the Nyamplung bean peeling machine, analysis was carried out using FEM (finite element method). This method aims to be a comparison between calculations using manual calculation analysis and using software so that construction errors can be minimized as can be seen in the flow chart in Figure 1.

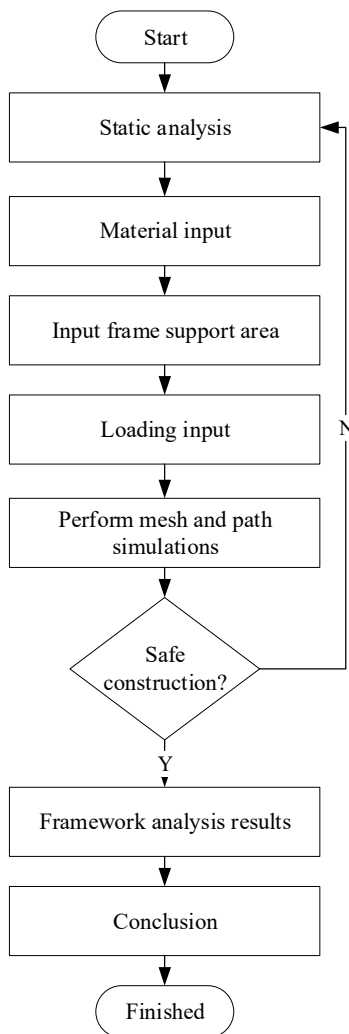

Figure 1. Flow chart of FEM analysis

## 3. RESULTS AND DISCUSSION

Von Mises simulation in Framework 1 using the finite element method (FEM)

Von Mises stress is a feature used to measure material failure or analyze several stresses or is called principal stress [17]. With this simulation, we can find out the ductility and elasticity of a

material so that when a load is applied to the frame construction it can return to its original shape so the frame can be said to be safe. We can see in [Figure 2](#) the simulation results of frame 1.

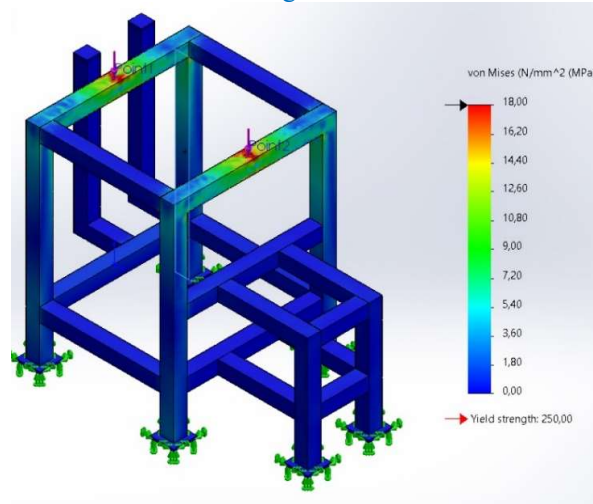

[Figure 2](#). Von Mises simulation results for frame 1

In the simulation using Solidworks, there is a maximum stress found in the analysis using FEM. In [Figure 2](#), the results obtained by simulation using the finite element method in Solidworks for the maximum stress have a value of 18 N/mm<sup>2</sup>. These results can be said to be safe because the stress obtained does not exceed the allowable strength of 160 N/mm<sup>2</sup> for ASTM A36 material. The construction uses hollow tube material 40 x 40 x 1.2mm.

#### Displacement simulation on frame 1 using finite element method (FEM)

Displacement is a movement towards the original position of the material under load. It can help describe the safety of the material you want to use before the production process is carried out. With this simulation, we can find out the creep that occurs in a material so that when a load is applied to the frame construction it can return to its original shape so the frame can be said to be safe. We can see in [Figure 3](#) the simulation results of frame 1.

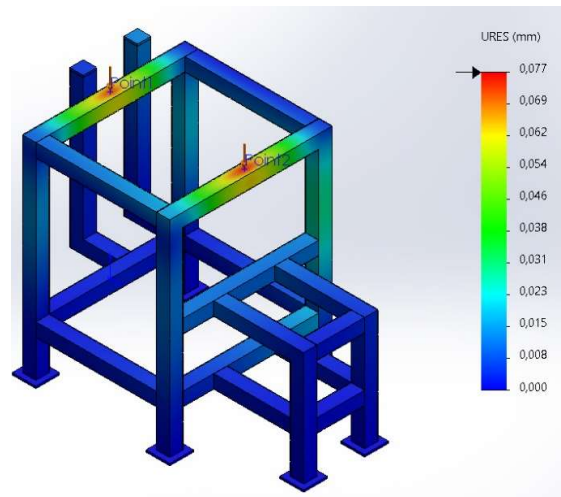

[Figure 3](#). Results of frame 1 displacement simulation

In the simulation in [Figure 3](#), the displacement obtained in the design of frame 1 of the nyamplung bean peeling machine under static loading is obtained. The results of the displacement in frame design 1, the displacement or change that occurs in the material is 0.077 mm. In this simulation, it is said to be safe because the change in shear is not too large.

#### Safety factor simulation on frame 1 using finite element method (FEM)

The safety factor is a factor used to evaluate so that the design or design created is guaranteed to be safe. The value of the safety factor is the most important in a design or design that will be made. When a system receives a load that is outside the calculation, the aim is to minimize failures during operation. The greater the safety factor, the better the design, or conversely, the smaller the safety factor, the design is said to be unsafe to use.

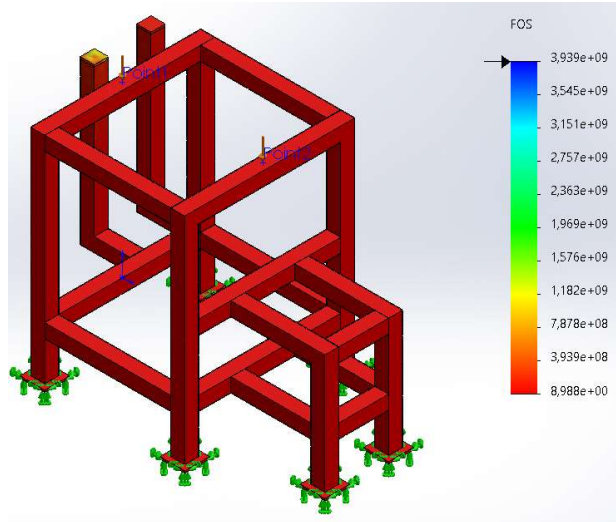

Figure 4. Safety factor simulation results for Framework 1

In the simulation in Figure 4, the safety factor obtained in the design of the nyamplung bean peeling machine framework under loading, the safety factor results obtained in the design using hollow tube material are 3.9. The minimum safety factor obtained is 1.2 so this construction is declared safe. If the safety factors are obtained in the simulation then changes to the construction design must be made.

Von Mises simulation in Framework 2 using the finite element method (FEM)

Von Mises stress is a feature used to measure material failure or analyze several stresses or is called principal stress. With this simulation, we can find out the ductility and elasticity of a material so that when a load is applied to the frame construction it can return to its original shape so the frame can be said to be safe. We can see in Figure 5 the simulation results of frame 2.

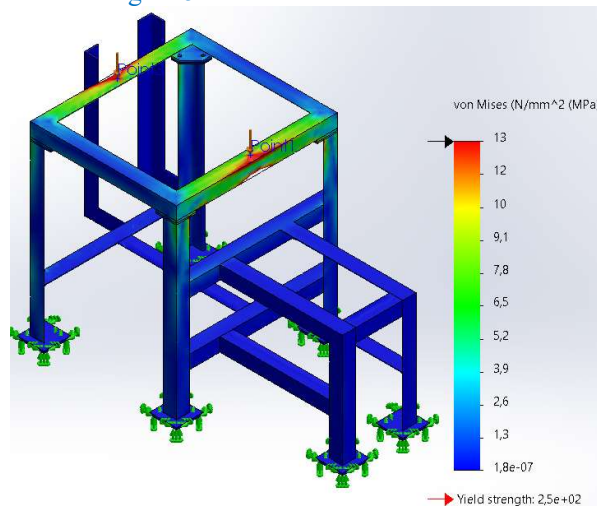

Figure 5. Von Mises simulation results for Framework 2

In the simulation using Solidworks, there is a maximum stress found in the analysis using FEM. In Figure 5, the results obtained by simulation using the finite element method in Solidworks for the maximum stress have a value of 13 N/mm<sup>2</sup>. These results can be said to be safe because the stress

obtained does not exceed the allowable strength of 250 N/mm<sup>2</sup> for ASTM A36 material. The construction uses angle iron material 40 x 40 x 5mm.

Displacement simulation on frame 2 using finite element method (FEM)

Displacement is a movement towards the original position of the material under load. It can help describe the safety of the material you want to use before the production process is carried out. We can see in Figure 4 the simulation results of frame 1.

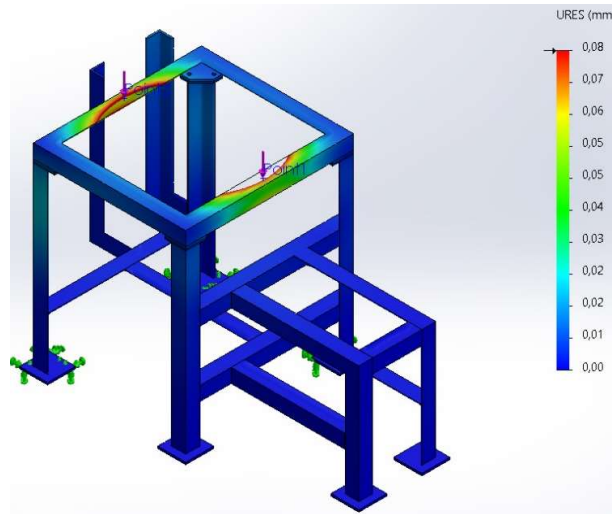

Figure 6. Results of displacement analysis of frame 2

In the simulation in Figure 6, the displacement obtained in the frame design of 1 Nyamplung bean peeling machine under static loading shows the results of the displacement in the design using angle iron material of 0.8 mm. The changes that occur are not so large that the material is still able to return to its original position. Because the nature of the material has elastic properties when a load is placed on the construction it can adapt to the conditions that occur. In frame design 2, it is quite small, no more than 1 mm of creep occurs in the frame of the nyamplung bean peeling machine.

Safety factor simulation on frame 2 using finite element method (FEM)

The safety factor is a factor used to evaluate so that the design or design created is guaranteed to be safe. The value of the safety factor is the most important in a design or design that will be made. When a system receives a load that is outside the calculation, the aim is to minimize failures during operation. The greater the safety factor, the better the design, or conversely, the smaller the safety factor, the design is said to be unsafe to use.

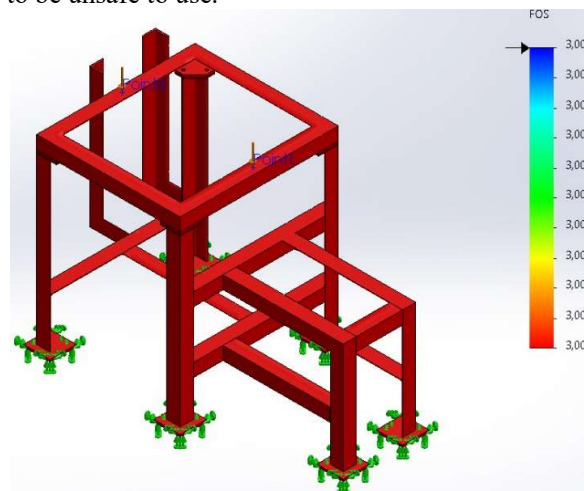

Figure 7. Results of safety factor analysis for framework 2

In the simulation in Figure 7, the safety factor obtained in the design of the nyamplung bean peeling machine framework under loading, the safety factor results obtained in the design using hollow tube material are 3.9. The minimum safety factor obtained is 1.2 so this construction is declared safe. If the safety factors are obtained in the simulation then changes to the construction design must be made.

Analysis results in both tests using finite element method (fem) and manual calculations

In simulations using Solidworks and manual calculations, results were obtained for frame design 1 with hollow tube material with a load of 490.2N. With this simulation, we can find out that the construction strength of frame design 1 is safe enough to use with hollow tube material specifications of 40 x 40 x 1.2 mm. In this design, the type of steel used is ASTM A36. In frame design 2 the results obtained are as good as frame design 1, however, this design uses angle iron material with material specifications of 40 x 40 x 5mm so it is safe to use on nyamplung bean peeling machines. The following are the results of the calculations for the two types of material, which can be seen in Table 1.

Table 1. Manual calculation results

No.	Symbol	The calculation results Framework 1	The calculation results Framework 2	$\sigma$ ASTM A36 Material Ijin
1	$\sigma_B$	19.94 N/mm <sup>2</sup>	13.83 N/mm <sup>2</sup>	160 N/mm <sup>2</sup>
2	$\delta_{max}$	0.120 mm	0.117 mm	1mm
3	$\tau_G$	2.63 N/mm <sup>2</sup>	1.307 N/mm <sup>2</sup>	160 N/mm <sup>2</sup>
4	$P_k < P_{cr}$	122,55N < 65.147,2N	122.55N < 67.224,2N	N/A

In Table 2 we can conclude which materials can be used. The two types of frame designs 1-2, which one is more efficient in making the frame for the Nyamplung bean peeling machine. From the results of the data that has been made, the use of hollow tubing material is more effective because the thickness is much smaller and the price of the iron is cheaper.

Table 2. Simulation results using FEM

No.	Calculation	Framework 1 calculation results	Framework 2 calculation results	$\sigma$ Ijin ASTM A36 material
1	Von mises	18 N/mm <sup>2</sup>	13 N/mm <sup>2</sup>	160 N/mm <sup>2</sup>
3	Displacement	0,077 mm	0,08 mm	1mm

In the simulation using Solidworks, there is a maximum stress and a minimum stress found in the analysis using FEM. The material used in this construction is a 40 x 40 x 1.2mm hollow tube and the steel specifications used ASTM A36 can be said to be safe because in the simulation it is still below the yield strength of the ASTM A36 material.

#### 4. CONCLUSION

Calculation of frame 1 using housing and crusher loading of 50kg. The results of the simulation obtained a bending strength of 18 N/mm<sup>2</sup>, while manual calculations obtained a result of 19.94 N/mm<sup>2</sup>. Allowable stress in ASTM A36 material 160 N/mm<sup>2</sup>. The displacement in manual calculations was found to be 0.120 mm, whereas using simulation it was 0.077 mm. In frame 2 the results obtained from manual calculations were with a bending stress of 13.84 N/mm<sup>2</sup>. With simulation, the results obtained were 13 N/mm<sup>2</sup>, and the displacement in manual calculations was obtained at 0.117 mm, whereas using simulation it was 0.08 mm.

#### REFERENCES

- [1] I. W. Muderawan and N. K. P. Daiwataningsih, "Pembuatan Biodiesel dari Minyak Nyamplung (*Calophyllum Inophyllum* L.) dan Analisis Metil Esternya dengan GC-MS," in *Prosiding Seminar Nasional MIPA 2016*, 2016.
- [2] R. : A. D. A. Redaktur: Andrean W. Finaka, "Apa Itu Bioetanol, Biodiesel, dan Biogas?"
- [3] H. S. Syamsul Ma'arif, R. Soelarso Pani, Moch. Chamim Chamim, "Prediction of Distortion

- Behavior due to Load Thermal Laser Welded Low Carbon Steel with Stainless Steel 304 based on Computation Simulation,” 2019. [Online]. Available: [https://www.researchgate.net/publication/334963914\\_Prediction\\_of\\_Distortion\\_Behavior\\_due\\_to\\_Load\\_Thermal\\_Laser\\_Welded\\_Low\\_Carbon\\_Steel\\_with\\_Stainless\\_Steel\\_304\\_based\\_on\\_Computation\\_Simulation](https://www.researchgate.net/publication/334963914_Prediction_of_Distortion_Behavior_due_to_Load_Thermal_Laser_Welded_Low_Carbon_Steel_with_Stainless_Steel_304_based_on_Computation_Simulation)
- [4] K. N. Salloomi, “Fully coupled thermomechanical simulation of friction stir welding of aluminum 6061-T6 alloy T-joint,” *J. Manuf. Process.*, vol. 45, 2019, doi: 10.1016/j.jmapro.2019.06.030.
- [5] B. A. Tayade, “A study on structural health of bicycle frame using Finite Element Analysis,” *Ijiere*, vol. 2, no. 4, pp. 36–41, 2015.
- [6] Firmansyah Azharul, Mohammad Fadel, and Rahmawati, “MENGHITUNG TEGANGAN STATIK PADA STRUKTUR RANGKA SEPEDA BMX MENGGUNAKAN SOFTWARE CATIA,” *TEKNOSAINS J. Sains, Teknol. dan Inform.*, vol. 7, no. 2, 2020, doi: 10.37373/tekno.v7i2.28.
- [7] S. P. Pratama, “Computational Fluid Dynamic ( CFD ) Analysis of Turbo Cyclone and Intake Manifold Spacer on Honda Supra Fit,” vol. 3, no. April, pp. 9–18, 2022.
- [8] K. Woloszyk and Y. Garbatov, “An enhanced method in predicting tensile behaviour of corroded thick steel plate specimens by using random field approach,” *Ocean Eng.*, vol. 213, 2020, doi: 10.1016/j.oceaneng.2020.107803.
- [9] A. A. Attorik, A. Ambiyar, D. Y. Sari, and B. Rahim, “SIMULASI DAN ANALISIS KEKUATAN PEMBEBANAN FRAME PADA PERANCANGAN MESIN PRESS BEARING MANUAL HYDRAULIC JACK MENGGUNAKAN AUTODESK INVENTOR,” *J. Vokasi Mek.*, vol. 4, no. 1, 2022, doi: 10.24036/vomek.v4i1.272.
- [10] A. Ghatei-Kalashami, S. Zhang, M. Shojaee, A. R. H. Midawi, F. Goodwin, and N. Y. Zhou, “Failure behavior of resistance spot welded advanced high strength steel: The role of surface condition and initial microstructure,” *J. Mater. Process. Technol.*, vol. 299, 2022, doi: 10.1016/j.jmatprotec.2021.117370.
- [11] R. Ariyansah and D. Mugsidi, “Effect of air velocity variation on hardness vickers of 6061 aluminum TIG welding joints,” *JTTM J. Terap. Tek. ...*, vol. 5, no. 2, pp. 187–194, 2024, [Online]. Available: <https://jurnal.stmcileungsi.ac.id/index.php/jttm/article/view/1018%0Ahttps://jurnal.stmcileungsi.ac.id/index.php/jttm/article/download/1018/556>
- [12] H. X. Yueqi Bi, Xiaoming Yuan, Mingrui Hao, Shuai Wang, “Numerical Investigation of the Influence of Ultimate-Strength Heterogeneity on Crack Propagation and Fracture Toughness in Welded Joints,” *Materials (Basel)*, vol. 15 (11), no. 3814, 2022, doi: DOI: 10.3390/ma15113814.
- [13] I. Sukmana, Egi Andika, Joy Rizki Pangestu Djuansjah, and Tarkono, “The effect of pre-heating distance of shielded metal arc welding on the mechanical properties of AISI 1045 steel,” *JTTM J. Terap. Tek. Mesin*, vol. 3, no. 2, pp. 108–114, 2022, doi: 10.37373/jttm.v3i2.312.
- [14] A. Chiocca, F. Frendo, and L. Bertini, “Evaluation of residual stresses in a pipe-to-plate welded joint by means of uncoupled thermal-structural simulation and experimental tests,” *Int. J. Mech. Sci.*, vol. 199, 2021, doi: 10.1016/j.ijmecsci.2021.106401.
- [15] V. Gia Hai, N. Thi Hong Minh, and D. T. Nguyen, “A study on experiment and simulation to predict the spring-back of SS400 steel sheet in large radius of V-bending process,” *Mater. Res. Express*, vol. 7, no. 1, 2020, doi: 10.1088/2053-1591/ab67f5.
- [16] O. Fariz Luthfi Nurulhadi, Rizal Hanafi, “Analisis Kekuatan dan Desain Frame Mini Bike 20 Inch Menggunakan Pendekatan Finite Element Method (FEM),” *J. Ilm. Wahana Pendidik.*, vol. 7, no. 1, 2021.
- [17] I. P. S. Asmara, F. Hamzah, and L. F. Susanti, “Structural analysis of single girder overhead crane using SS400 and ST52-3 steel plate,” in *Journal of Physics: Conference Series*, 2020. doi: 10.1088/1742-6596/1450/1/012130.