

# Real-Time Telemetry Data Monitoring System on Soil Movement of Railway Tracks

Teguh Arifianto<sup>1</sup>, Anindira Listy<sup>2</sup>, Sunardi<sup>3</sup>

<sup>1,3</sup>*Railway Electrical Engineering Indonesian Railway Polytechnic, Indonesia*

<sup>2</sup>*Electrical Engineering, Sultan Agung Islamic University, Indonesia*

<sup>1</sup>teguh@ppi.ac.id (\*)

<sup>2</sup>diraanin@gmail.com, <sup>3</sup>sunardi@ppi.ac.id

**Abstract**— A telemetry data monitoring system is needed to monitor land shifting. This system consists of an ATmega328 microcontroller, a Linear Variable Differential Transformer (LVDT) and a rheostat, an accelerometer sensor, a rain gauge tipping bucket, and the HC-12 radio telemetry module. Normally, the LVDT reads the land shift in the 0-20 mm range, the Rheostat is capable of shifting up to 66 mm, the accelerometer sensor reads less than 20 deg of data, and the rain gauge tipping bucket sensor creates the amount of rainfall below 50 mm/hour which is then sending real-time data regularly for 24 hours. The buzzer installed in the field will sound if the LVDT reads land shift more than 30 mm, Rheostat more than 51 mm, and the accelerometer sensor reads data more than 45 deg; also, the rain gauge tipping bucket sensor reads more than 70 mm/hour. This test creates parameter data. So that shift data can be monitored.

**Keywords**— Monitoring, Telemetry, Real-Time, Land Shift.

## I. INTRODUCTION

According to the BNPB Performance Report in 2019, the landslide disaster is the fourth most disaster in Indonesia [1]. Conditions such as slopes, volcanic activity, and even weathering can cause soil movement [2]. Soil movement can easily cause landslides [3]. According to Azkin, landslides' leading cause is the gravitational force that affects steep slopes such as soil movement and excess water due to high rainfall [4]. High rain causes changes in soil pressure, leading to structural changes and collapse [3].

On April 6th, 2014, the *Bandung-Malang Malabar* Train had an accident [5]. The train travels 20 meters while crossing unstable land [5]. Based on information from the BPBD of the *Tasikmalaya* Regency, three points of vulnerable areas, namely *Ciawi*, *Kadipaten*, and *Manonjaya*, often experience moderate to high soil movements [5].

Previous research about landslide early warning systems uses the same parameters, consisting of angular displacement, ground movement, and rainfall [6]. But the data transmission method uses a GSM module with the SMS feature that requires a fee for text delivery, and the GSM module depends on the internet [6]. To solve this research's weakness, data transmission uses the HC-12 module with the long-distance wireless transmission with a working FSK frequency of 433.3-473.0 MHz, up to 100 communication channels [7].

In areas prone to landslides, information and evacuation measures easily accessible to the public are needed. The Linear Variable Differential Transformer (LVDT) sensor can be used to measure the displacement of an object [8] [9] [10], which can be developed into a ground motion measurement [11]. Thus, a long-distance communication system is needed so that ground movement can be monitored in real-time. This system uses a telemetry system that transmits data with FSK modulation via analog radio [9]. The radio output then produces monitoring data, which is monitored continuously.

The telemetry system was created to remotely transducers and sensors that can detect ground movement at any time in vulnerable areas on the railroad.

## II. RESEARCH METHODOLOGY

The experimental remote measurement system for soil displacement, soil slope, and rainfall determines the characteristics of the potential landslide warning system. Reference data were obtained at Resort 4.21 *Gundih* KM 60 + 7/8 and KM 67 + 0/1 on March 21st, 2020. This data is used as a reference for designing a telemetry system to warn of potential landslides and ground movement. The telemetry system design model has been tested in the Madiun PPI station laboratory from July to September 2020. A 10-meter displacement detector is installed, and the first sensor is installed 2.5 meters from the axle rail.

### A. Method of Initial Testing on the System

Before the system is used to take data experiments, the system is tested to match the expected data results. The test was carried out in the Electronics Lab using supporting devices, namely, a digital multimeter and variac.

1) *LVDT Sensor Tests*: The LVDT sensor circuit is connected to a variac. For the maximum Shift to be known, the LVDT sensor's core is shifted to the right, then to the left until it reaches the maximum voltage. The voltage value is observed on a digital multimeter to determine the voltage linearity with the shift distance.

2) *Rheostat Tests*: The rheostat test uses the variac as the source voltage, and the Rheostat connects to a digital multimeter. Then, make observations on the resistance to determine the minimum and maximum limits of the Rheostat working.

3) *Accelerometer Sensor Tests:* Accelerometer sensor testing is done by looking at the sensor output value for ground movement. From the reading of the sensor value, it can be known the set point on the sensor when conditions are perpendicular. So, value changes can be processed when the sensor is moved.

4) *Tipping Bucket type Rain Gauge Sensor Tests:* The sensor test is carried out using the calibration method. The calibration method is used to determine the reliability of the sensor.

5) *Telemetry Radio Module Tests:* The HC-12 telemetry module test by connecting the transmitter and receiver. The connection test is done by connecting the appropriate channel address. After the channel match, the module is ready for use.

**B. Method of Collecting Data**

Reference data for telemetry system design for landslide-prone area data were obtained from the DAOP 4 line unit and the DAOP 4 Semarang area bridge office. Then at the Central Statistics Agency (BPS) Purwodadi area, rainfall data were obtained. And 4.21 Gundih data from the entire resort area and cross-section images obtained through observations at the 4.21 Gundih Resort Line and Bridge Unit.

**C. Method of Processing Data**

After the sensor is tested, continue to test the landslide warning telemetry system's potential using reference data to measure the LVDT sensor, Rheostat, accelerometer sensor, and rain gauge tipping bucket sensor. This research includes calibration testing, ADC (analog to digital converter) conversion, and sensitivity.

Calibration testing is carried out on the acceleration sensor, rain gauge tipping bucket sensor, LVDT, and rheostats. The test is used to determine the system output value's closeness and the standard measuring instrument to understand system reliability [11].

The ADC conversion test is used for the rheostat and LVDT sensors. Voltage output data is analog data that can be converted into equations and processed as follows Equation (1) on a microcontroller [14].

$$BIT = 2^n \tag{1}$$

The ATmega 328p microcontroller support 10 bit ADC systems, which have a binary value of  $2^{10}$  based on Equation (2).

$$Land-shift = (ADC+1) / 102,3 \tag{2}$$

Where:

$ADC$  = source voltage on the sensor

$102,3$  = binary value for 10 bit

$n$  = the number of bits

The LVDT and Rheostat sensors' sensitivity test in this research was determined based on the transfer function of the output voltage curve to the displacement distance. The transfer function is taken from the LVDT voltage curve and graphs the

most linear data of the Rheostat relative to the distance in the linear direction. In this research, Microsoft Excel software can be used for calculations to determine the transfer function and sensor sensitivity [13]. The linearity of straight-line equations can also be seen from linear correlation (R2) [13], and the straight line equation used is the regression curve equation. The straighter the curve, the higher the linearity [14] based on Equation (3).

$$y = a + bx \text{ (linier)} \tag{3}$$

$$y = ae^{bx} \text{ (exponential)}$$

Information:

$$b = \frac{\sum x_i y_i - (\sum x_i)(\sum y_i)/n}{\sum x_i^2 - (\sum x_i)^2/n} = \frac{n \sum x_i y_i - \sum x_i \sum y_i}{n \sum x_i^2 - (\sum x_i)^2}$$

$$a = \bar{y} - b\bar{x}$$

$y$  = land shift (mm)

$x$  = LVDT sensor and rheostat voltage (mV)

After knowing the shape of the approximate curve, we can determine the constant of the Equation. If the value of  $x$  is known, the regression line  $y = a + bx$  is used to estimate the value of  $y$ .

**D. Data Analysis**

Data analysis includes system design using hardware and software. The hardware consists of an ATmega 328p microcontroller, an LVDT sensor, a rheostat, a tipping bucket-type rainfall sensor, and an ADXL345 accelerometer sensor. Meanwhile, the software consists of Microsoft Visual Studio, Arduino IDE C Language, AVR Khazama, and XAMPP programmers. The landslide warning telemetry system uses the HC\_12 wireless serial port communication module, USBASP as the transistor-transistor logic (TTL) serial sender, Microsoft Visual Studio software as a computer viewer, and phpMyAdmin as the database processor.

1) *Soil Movement Measurement Design:* In this research, ground motion measurement used a transducer rheostat, LVDT sensor, accelerometer, and tipping bucket type rainfall. Rheostats are used to determine the vertical movement of the ground on the surface. The Rheostat is mounted in a transverse direction, and the LVDT sensors are mounted longitudinally as far as 10 meters each. Both attachments are attached to nylon strings to spread them, which are attached by rods as in Figure 1.

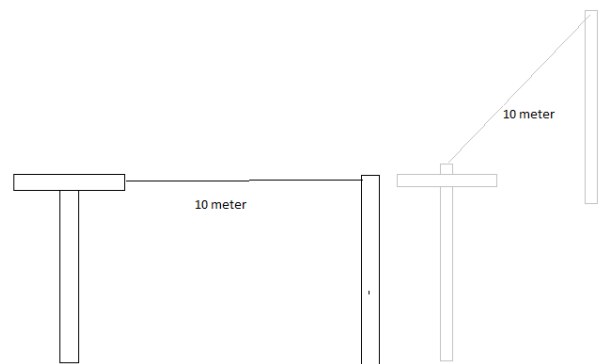

Figure 1. Rheostat and LVDT Installation Design

On the accelerometer sensor that is mounted in the ground. This installation aims to determine the movement of the soil in the ground. Meanwhile, the tipping bucket type rainfall sensor is installed above the ground. Installation of a rainfall sensor is intended to determine the rainfall capacity experienced in the area.

2) *Hardware Circuit Design (Hardware)*: The system's hardware includes an electronic circuit in the form of a power source as a power source and a minimum system circuit as a data processing center. The results of the circuit image route are shown in Figure 2.

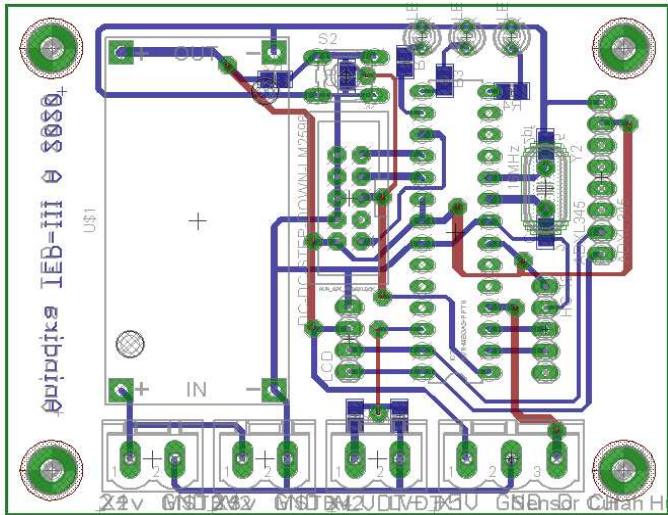

Figure 2. Circuit Board Design

3) *Software Design*: Programming in this tool is divided into two parts: using the Arduino IDE software to program each sensor and using Microsoft Visual Studio software to create a Graphical User Interface (GUI) on a PC. In the telemetry system, landslide potential warnings have a flow based on the flowchart description shown in Figure 3. The ATmega 328p minimum system initialization program consists of initializing the ADC, LCD, serial/ USART, and timer. The main program is a program that is used as a sub-routine to read shift data to send data and determine potential landslide warning signals. The process of sending data and determining potential landslide warning signals. The process of sending data is divided into three parts, namely, sending data to check the connection, sending routine data that will be sent every 1 minute, and sending data when an event occurs in 1 second. This means that the microcontroller system will instruct the HC-12 wireless communication module to send regular data continuously. So, the data that the user is known is always updated. Figure 4 shows an LVDT sensor, accelerometer, rain gauge, and Rheostat as inputs in the block diagram. The LVDT sensor is used to detect the vertical ground shear distance, and the Rheostat is used to detect the horizontal shear distance. The ATmega 328p microcontroller runs this process. The process carried out is receiving data input from the sensor then process the sensor data. If there is a potentially dangerous "High"

warning indicator, then the bell will light. If the level reaches "moderate" and "low" danger status, only a warning will appear on the interface.

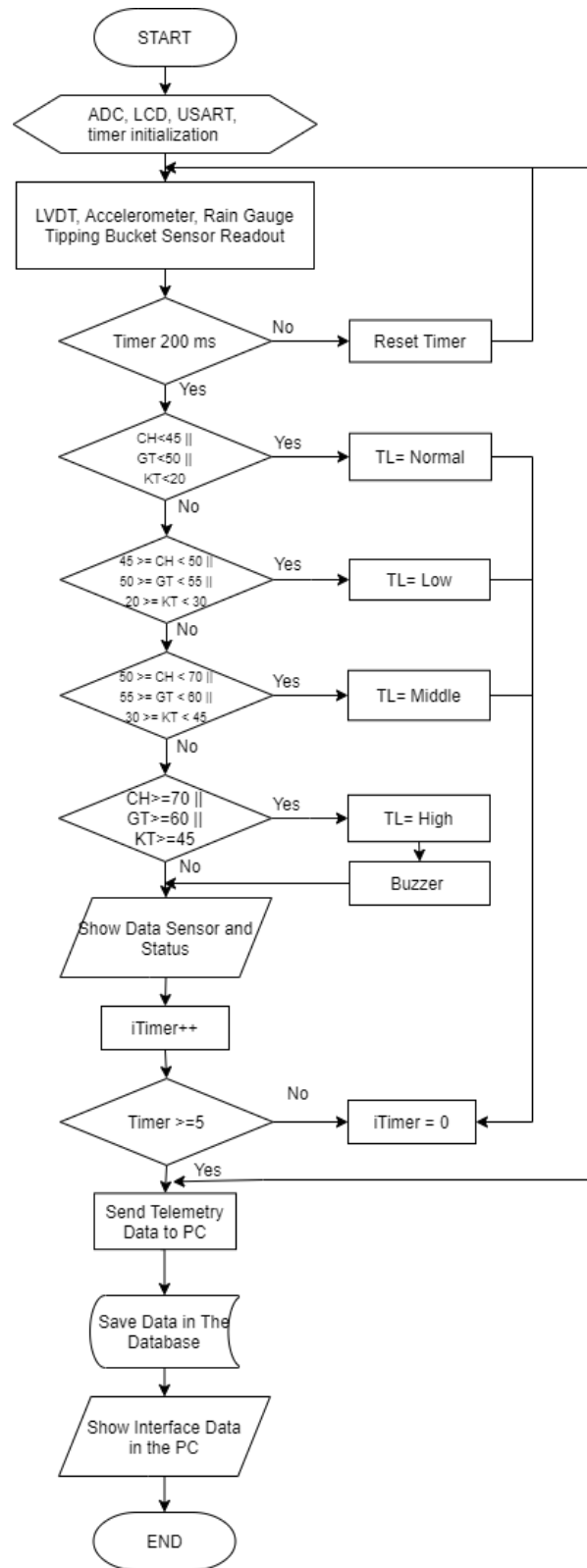

Figure 3. Flowchart Program

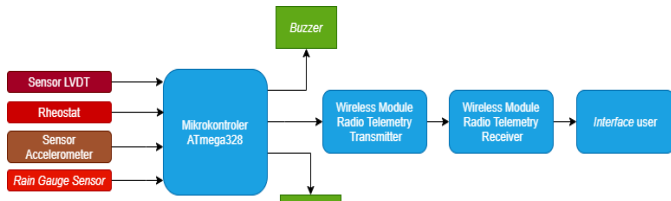

Figure 4. Telemetry System Block Diagram

At the same time, always updated data will be displayed in the LCD field and user interface. At the output end, the data is sent wirelessly via the HC-12 wireless serial port communication module, and then the data will be monitored on the user interface. Data transmission has been tested with one of the sensors to the test data transmission for 24 hours.

### III. RESULT AND DISCUSSION

The hardware that has been made uses an ATmega 328p microcontroller, a rainfall sensor, an LVDT sensor, and an ADXL345 accelerometer. This system has supplied by 24 Volt AC power is shown in the following figure 5.

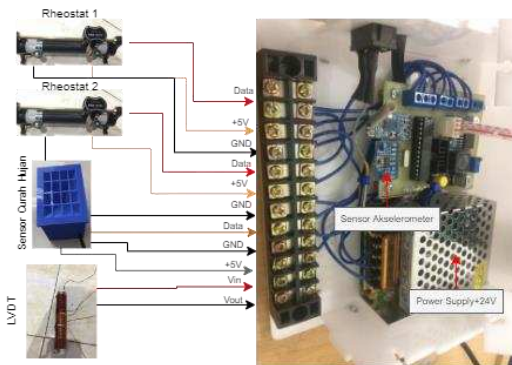

Figure 5. Circuit of Land shift Detection System

#### A. LVDT Sensor Tests Results and Rheostat

The LVDT sensor and Rheostat are applied at the location of the Indonesian Railway Polytechnic Laboratory. Testing of the LVDT sensor and Rheostat is done by connecting the circuit to the 5 Volt AC variac source. The output voltage in the form of secondary voltage is measured using a digital multimeter. The test is carried out at a distance of 0-41 mm with a shift to the right (positive) and left (negative) each 20mm. The measurement results in Table I (a) and (b).

TABLE I  
 TEST RESULTS OF LVDT SENSOR AND RHEOSTAT

LVDT Sensor		
Shift Range (mm)	Readable Shift (mm)	%Error
1	2	0%
2	2	0%
3	3	0%
4	4	0%
5	5	0%
6	6	0%
7	7	0%
8	8	0%

LVDT Sensor		
Shift Range (mm)	Readable Shift (mm)	%Error
9	9	0%
10	10	0%

(a)

Rheostat			
Readable Shift			
Rheostat 1	%Error	Rheostat 2	%Error
0	0%	0	0%
9	10%	10	0%
20	20%	19	5%
30	0%	29	3,3%
41	2,5%	39	2,5%
50	0%	48	4%

(b)

Based on the results of using the LVDT and Rheostat sensors, after a 5 mm drop, the error percentage is getting smaller, even reaching 0%. Besides, after using the LVDT sensor and Rheostat 5 times, the error percentage is an average of 1.97%. This indicates that the LVDT sensor and Rheostat are accurate. Figure 6 shows the results of using the accuracy.

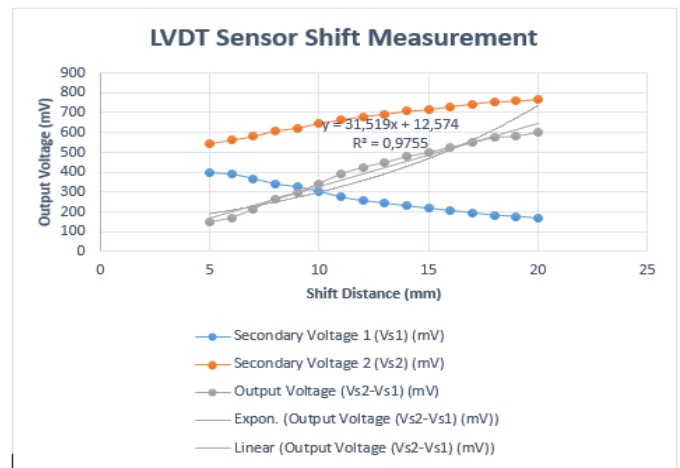

(a)

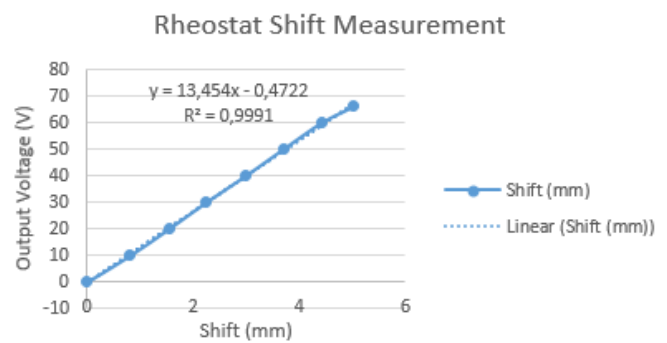

(b)

Figure 6. Graph LVDT Sensor Rest Results (a) and Rheostat (b)

The movement distance and output voltage are linear. Both are by the R-squared value, which results in a value of 0.9755 close to the value 1. The relationship between movement distance and the output voltage is linear. Based on the Equation obtained, it can be seen that the R-squared value obtained is 0.9991. The R-squared value is close to the value 1.

**B. Accelerometer Sensor Tests Results**

Accelerometer sensor testing is one by reading the sensor output value. Sensor accelerometer read the output value when the sensor is in a certain position so that the average range of the sensor readings to the Shift can be seen. The accelerometer sensor is made with a determined tolerance value when the slope value is <20 deg when in normal conditions. When the sensor at a slope of 20-30 deg indicates a low landslide potential, the LCD and software display a low hazard notification. The sensor at a slope of 30-45 deg indicates a moderate landslide potential, the LCD and software display a moderate hazard notification. Meanwhile, when the tool is at a slope of >45 deg, the buzzer lights up, software, and LCD high hazard notification.

Figure 7 (a), (b), (c), and (d) show the acceleration sensor testing based on the ground moving forward, backward, upright, left, and right, which produces the following data.

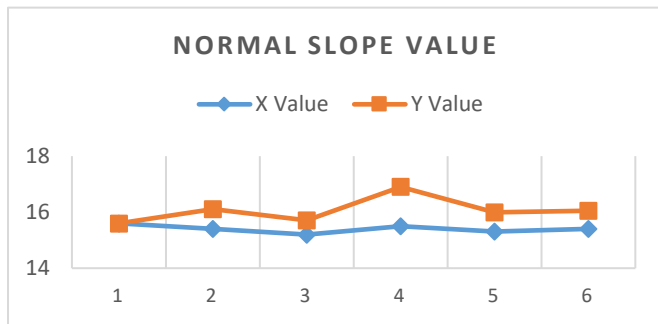

(a)

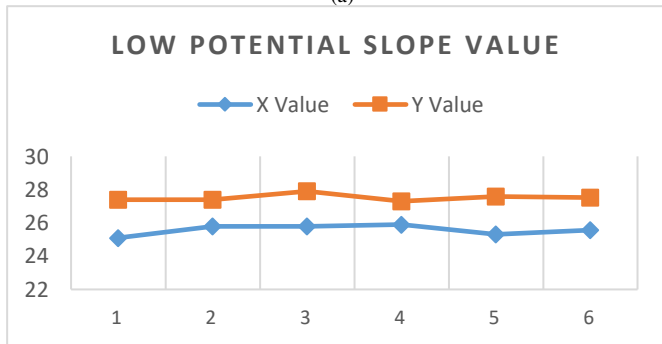

(b)

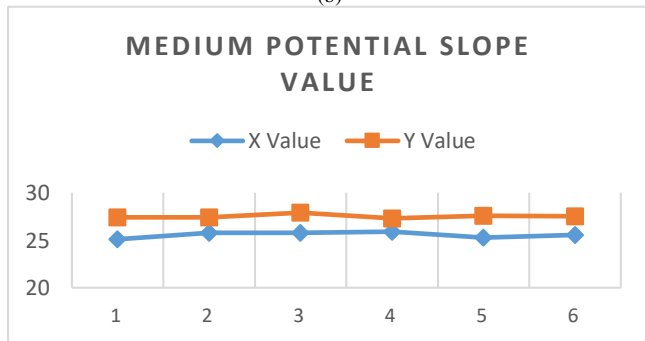

(c)

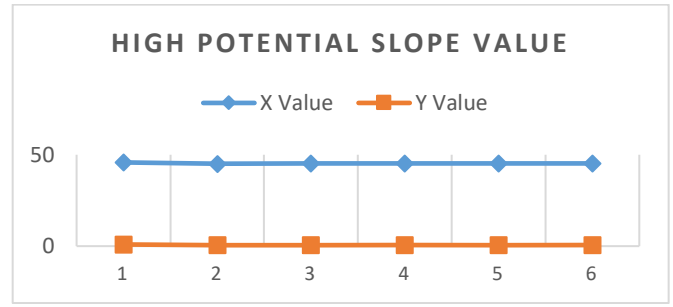

(d)

Figure 7. Slope Graphics

Based on the results in Figure 7 (a), (b), (c), and (d), it shows that when the sensor moves back and forth on the test soil, the mean values of X are 2.08 and 1.86, and the Y values were 15.44 and 15.28, respectively. When the sensor moves left and right, under normal conditions, the mean slope of X is 15.22 and 15.4 and Y is 3.02 and 0.66. When the sensor is installed vertically, the slope values of X and Y are 0.76 and 2.48, respectively.

**C. Tipping Bucket Rain Gauge Sensor Tests Results**

Tipping bucket type of rainfall sensor tests is carried out by conducting simulations in the field by dripping simulated rain-water within 2 hours to determine which conditions match the expected criteria. So that, after knowing the sensor's ability to accommodate rain, a calibration is carried out to provide a setpoint value.

The results of sensor testing based on rainfall intensity are based on three criteria, namely: 1) total rainfall less than 50 mm, 2) total rainfall 50 mm-70 mm, 3) total rainfall exceeding 70 mm. The test results are described in Table II.

TABLE II  
 POTENTIALS OF SOME CONVERSION OF RADIONUKLIDA

No.	Time (minutes)	Total Rainfall / mm	Shift (mm)
1.	0	3	1
2.	1	2	2
3.	2	0	3
4.	3	1	4
5.	4	2	5
6.	5	3	6
7.	6	2	7
8.	7	5	8
9.	8	1	9
10.	9	3	10
11.	10	4	11
12.	59	1	60

**D. Radio Telemetry Test Results in Observation of Delivery Distance**

The radio telemetry testing results are to observe the transmission distance based on the distance and standards that do not exceed the maximum limit in meters. The explanation of the test results is described in Figure 8 as follows. Figure 8 shows that the HC-12 communication module has successfully transmitted data up to a distance of 600 m. This is following the technical specifications on the HC-12 module.

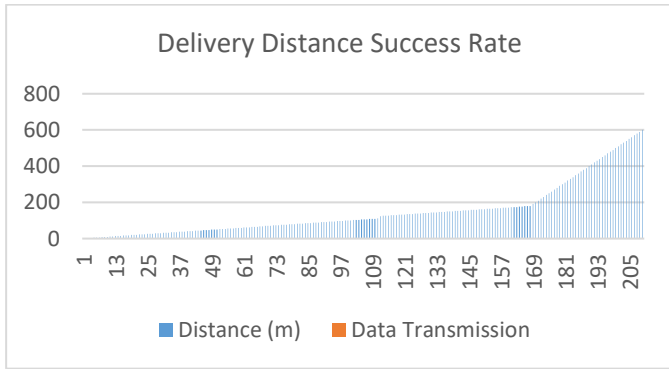

Figure 8. Delivery Success Rate Graphic

E. Radio Telemetry Test Results in Observation of Delivery Distance

The Telemetry System circuit in Figure 9 represents sending data is carried out using the HC-12 wireless serial port communication module displayed through the Graphical User Interface (GUI) in Microsoft Visual Studio. Then, the data is stored in the phpMyAdmin database.

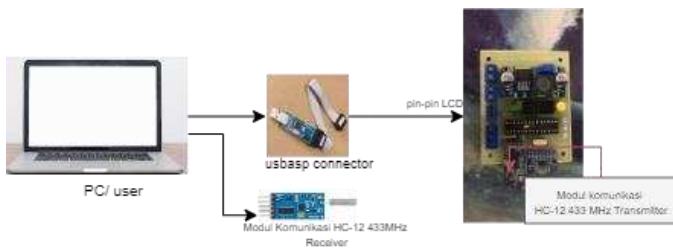

Figure 9. Circuit of Telemetry System

In this system, Microsoft Visual Studio is used to create a GUI. The script used is C # Visual Studio. The GUI displays data about rainfall (mm / hour), the Shift of the x-axis and y-axis (degrees), and ground movement (mm). The interface application test results produce the following simulation, and database tables are shown in Figures 10 and 11.

Based on Figures 10 and 11, the test is carried out by connecting the appropriate COM7 to the radio transmitter and receiver module. Then the application is connected to the database via the phpMyAdmin web.



Figure 10. Application Interface

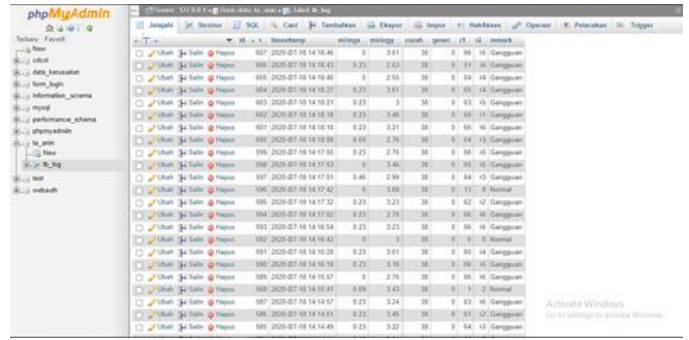

Figure 11. Database Testing Results

F. Overall Test Results

On the PPI Madiun Laboratory's left side, testing the entire telemetry data forecasting system is carried out. The ground motion detector installation distance is 10 meters. The LVDT sensor installation is placed from the axle rail to the LVDT sensor along 2.5 meters. Meanwhile, the LVDT sensors, rheostat 1, and rheostat 2 are installed with a distance of 3.3 meters each.

Based on the results of the tests carried out, the resulting data in a position where the x and y coordinate values are lower than 20 deg have normal conditions, while the data represented by a position where the x and y coordinate values are higher than 21 deg experience interference. The value of rainfall data (CH) under normal conditions is less than 45 deg. Meanwhile, the CH value is greater than 46 deg, thus indicating a potential disturbance. The Rheostat and LVDT sensors' movement is less than 50 mm, and it can be said that the movement is normal, and the movement of the sensor that is greater than 51 mm can be said to have the potential for interference. The results of testing the entire ground motion detector are described in Table III.

TABLE III  
 OVERALL TOOL TEST RESULTS

5' to	Date	Sb X (°)	Sb Y (°)	CH (mm / min)	GT (mm)	Rh1 (mm)	Rh2 (mm)	Info
1	07-18-2020 / 14:18	0	3.46	38	0	65	65	Distracti on
2	07-18-2020 / 14:13	0.23	3.24	38	0	63	66	Distracti on
3	18-07-2020 / 14:09	0.46	2.96	29	0	59	63	Distracti on
4	18-07-2020 / 14:04	0	3.24	18	0	11	3	Normal
5	18-07-2020 / 13:59	0	2.77	34	0	48	53	Distracti on
6	18-07-2020 / 13:54	0	3.01	29	0	1	10	Normal
7	07-18-2020 / 13:49	5.92	35.14	0	15	65	43	Distracti on

#### IV. CONCLUSION

To view monitoring data in anticipation of potential landslides, it can conclude that the linearity coefficient of the LVDT sensor-shift distance of 0.975 and the rheostat shift distance of 0.9991. The accelerometer sensor's tilt angle calibration is moved forward and back with a high potential of landslides on average x, y (45.62, 45.46) degrees. Rainfall capacity calibration with a standard range of 0-45 mm, a middle range of 50-69 mm, and a high range of more than 70 mm. the maximum transmission distance of the HC-12 communication module is 600 m. Telemetry data transmission is 99.9% successful, but 1 time has a 1-minute delay.

The monitoring data through an interface application connected to the database can regularly send data. Then, reports can be appropriately delivered according to the level of risk of potential landslide disasters. This research needs to be further developed. Development can be done by widening the measurement range of the LVDT sensor. Radio telemetry coverage can also be extended, and the underground detection can be re-tested with water absorption parameters.

#### V. ACKNOWLEDGMENT

The author is particularly grateful to the Director of PPI Madiun, Amirulloh, who has provided data access so that the author can carry out this research properly.

#### REFERENCES

- [1] T. S. Doni Monardo, "Laporan Kinerja BNPB," Badan Nasional Penanggulangan Bencana, Jakarta, 2019.
- [2] Paimin, Sukresno and I. B. Pramono, Teknik Mitigasi Banjir dan Tanah Longsor, Bogor: Tropenbos International Indonesia Programme (2009), 2009.
- [3] H. A. Nugroho, R. H. P., Suharni, A. T. Sutanto and Hariyanto, "Rancang Bangun Real Time Monitoring dan Peringatan Dini Tanah Longsor Berbasis Risiko," Prosiding Seminar Nasional Fisika (SINAFI) 2018, pp. 302-306, 2018.
- [4] D. F. Supriyadi, "Sistem Monitoring Pergeseran Tanah Terhadap Potensi Longsor Secara Wireless Berbasis Mikrokontroler," ADLN-Perpustakaan Universitas Airlangga, Surabaya, 2016.
- [5] H. Ardia, "Kecelakaan Kereta Malabar," *Bisnis.com*, 6 April 2014. [Online]. Available: <https://ekonomi.bisnis.com/read/20140406/98/217336/kecaccident-kereta-malabar-penyebab-masih-diinvestigation-knkt> . [Accessed 2020 May 13].
- [6] K. J. A. M. A. J. S. T. M. B. M. Crissa D. Fernandez, "Development of Microcontroller-based Landslide Early Warning System," IEEE Region 10 Conference (TENCON)-Proceeding of the International Conference, pp. 3000-3005, 2016.
- [7] D. Bailey, Practical Radio Engineering and Telemetry for Industry, Australia: Newnes, an imprint of Elsevier, 2003.
- [8] K. Baidwan and C. Kumar, "Design of Linear Variable Differential Transformer (LVDT) Based Displacement Sensor with Wider Linear Range Characteristics," *The International Journal of Science & Technoledge*, vol. 3, no. 4, pp. 74-79, 2015.
- [9] A. N. H and George, "Design and Development of a Planar Linear Variable Differential Transformer for Displacement Sensing," *IEEE Sensors Journal*, Vols. 5298-5305, p. 17 (16), 2017.
- [10] W. Jefriyanto, E. Satria and M. Djamal, "Pengembangan Sensor LVDT (Linear Variable Differential Transformer dengan berbagai Konfigurasi)," Prosiding SKF 2017, pp. 66-73, 2017.
- [11] W. Jefriyanto, B. G. M. Saka and M. Djamal, "Desain Prototype Sensor Pergerakan Tanah Dengan Menggunakan Sensor LVDT (Linear Variable Differential Transformer)," *Neutrino-Jurnal Pendidikan Fisika*, vol. 2, no. 1, pp. 25-29, 2019.

- [12] Y. P, Y. PN, L. K, R. L, W. Sp and R. O, "Sistem Telemetri Simulasi Mitigasi Bencana Kegempaan dan Deteksi Peningkatan Kadar Konduktivitas Belerang pada Gunung Berapi Berbasis Wireless 802.15.4," *Jurnal Pendidikan Fisika dan Aplikasinya (JPFA)*, vol. 4, no. 2, pp. 15-21, 2014.
- [13] Z. Hendri and Wildian, "Pembuatan dan Karakterisasi LVDT sebagai Sensor Jarak," *Jurnal Fisika Unand*, vol. 2, no. 3, pp. 170-179, 2013.
- [14] Y. M. P. D. Prof. Drs. Sukestiyarno, *Olah Data Penelitian Berbantuan SPSS*, Semarang: Universitas Negeri Semarang, 2016.