

## **ANALYSIS OF THE INFLUENCE OF PROFIT VALUE AND RESTAURANT AMBIENCE ON RETURN VISIT INTENTION MEDIATED BY CUSTOMER SATISFACTION (A Case Study of Restaurant Consumers in Surakarta)**

Zahrotus Salsabila<sup>1</sup>

<sup>1</sup>Universitas Muhammadiyah Surakarta  
Indonesia  
plala564@gmail.com

### ***ABSTRACT***

*This study aims to analyze the effect of perceived value and restaurant atmosphere on customer satisfaction which will then influence customer intentions to revisit. Researchers used 151 people as a sample with the criteria of having eaten at a restaurant at least once. According to the criteria of the respondents who have been determined, the sampling method using purposive sampling. Data were analyzed using SEM-PLS and processed using Smart PLS 3. The findings verified the value of the benefits perceived by customers and the atmosphere of the restaurant had a significant positive effect on customer satisfaction. Customer satisfaction was confirmed as a significant positive effect on revisit intention.*

*Keywords: Atmosphere, Customer satisfaction, Perceived value, Restaurant, Revisit intentions*

---

### **INTRODUCTION**

The increasing number of people makes the need for daily food also increasing. The restaurant industry is mushrooming in various places as a response to consumer demand. Restaurants are the choice of many consumers to fill their stomachs without spending a lot of time cooking. Many restaurants give rise to business competition that motivates restaurant owners to maintain their popularity. One way to maintain a restaurant business so as not to lose customers is to make sure customers are satisfied and don't feel disadvantaged after visiting a restaurant. Therefore, fulfilling customer satisfaction factors is important for the survival of the restaurant business.

Customer satisfaction is a psychological point of view or customer mood that must be considered (Feng et al., 2019) as the key to the company's success (Uzir et al., 2020). Customer satisfaction can be seen from the benefits that customers get when visiting restaurants. According to (Uzir et al., 2021), customer perceived value is a significant predictor of customer satisfaction. Consumers consider the use value and price of a product to conclude the value of the benefits that will be obtained (Konuk, 2019). In line with opinion Zeithaml (1988) who stated that perceived value is defined as a consumer's

overall evaluation of the usefulness of a product based on perceptions of what is received in return for what is given.

The quality received and the price paid by the customer are important factors that determine the value of profits. Consumers define price as the amount of something sacrificed to obtain the product (Konuk, 2019). Consumers perceive benefits to be obtained if the value of the product received is of comparable quality to what the consumer has spent. However, if the value of the product received does not match the value sacrificed, it means that the customer does not benefit. Food pricing should be considered based on the quality of food served and competitors' prices. Prices that match the quality of food worth buying make for a fair price. Therefore the perceived value of the customer will increase. That is, price and quality become one of the factors forming the value of the benefits received by customers, namely as one of the vital factors that contribute to customer satisfaction (Konuk, 2019). This study intends to examine how the customer's perceived value which includes price fairness and price compatibility with food affects customer satisfaction.

Then, the atmosphere of the restaurant can also affect consumer satisfaction. Atmosphere is the most prominent influence on customer satisfaction in restaurants, in the context of Covid-19 safety precautions. Customers who come to the restaurant in groups show a lot of concern for the atmosphere, which in this case concerns the COVID-19 safety precautions, while customers who come alone do not (Zibarzani et al., 2022).

When the quality of the physical environment and the quality of the food provided are equivalent, in the context of a luxury hotel restaurant, customers with high attention when consuming a product have stronger levels of satisfaction than customers with low attention. The results also show that the quality of the physical environment has a significant effect on customer satisfaction (Han and Hyun, 2017). Therefore, researchers are interested in studying how the quality of the physical environment can affect the satisfaction of customers who eat at restaurants.

Then, research (Assaker et al., 2011) shows that a low level of customer satisfaction causes a decrease in repeat visit intentions, on the contrary, high satisfaction increases the likelihood of short and long term repeat visit intentions in the context of tourist destinations. In line with opinion Han and Ryu (2012), the intention to revisit may decrease when the customer does not find satisfaction.

Overall, the profit value and atmosphere of the restaurant are important components in explaining customer satisfaction which will then lead to repeat visit intentions. Based on the explanation above, this study focuses on discussing the effect of perceived value and restaurant atmosphere on customer satisfaction. Then look at the mediating role of customer satisfaction on the relationship between perceived value and atmosphere on revisit intentions.

## LITERATURE REVIEWS

## Perceived value

Perceived value is something that customers expect from a product or service. Zeithaml (1988) said, perceived value refers to "the consumer's overall assessment of the benefits of a product or service, determined by the consumer's perception of what is received and what has been given by the consumer for the product". Perceived value is measured through a consumer perception measurement scale that includes four dimensions value, namely price, quality, social, and emotional. This means that pleasure after consuming the product is also a concern of consumers when evaluating the product (Laukkanen and Tura, 2022).

Overall consumer ratings including price and perceived quality are important determinants of perceived value. Liljander and Strandvik (1993) argues that perceived value is defined as a measure of the benefits derived from a product and the price paid by the customer for the product. According to the attributes related to price, such as proper food prices that affect restaurant customer satisfaction need to be considered. Food that has a reasonable, acceptable and fair price according to the food received by the customer makes the customer's perception of perceived value increase (Konuk, 2019). Consumer perception of an item will be positive if the benefits obtained exceed the sacrifices incurred (Peng et al., 2019). This means that if customers have a high perception of price fairness, then customer satisfaction with the restaurant will also be higher (Konuk, 2019).

Previous research (Uzir et al., 2021; El-Adly, 2019; Konuk, 2019; Nami, 2017; García-Fernández et al., 2018) verify the significant impact of perceived value on consumer satisfaction. Perceived value is an interesting topic to study because it determines customer satisfaction. Therefore, hypothesis one appears.

### **H1: Perceived value has a positive effect on customer satisfaction**

## Atmosphere

The atmosphere of the restaurant is created through the quality of the physical environment that is served. Interior layout, restaurant cleanliness, and restroom areas are important components of the physical environment. Customers will pay attention to the quality of the physical environment in which they eat food (Clemes et al, 2015). Ryu and Han (2011) said the atmosphere of the restaurant makes an important contribution in creating a dining experience for restaurant customers which can then provoke positive emotions from customers. Interior design, layout, temperature, and employee appearance as several indicators that represent the atmosphere can affect customer comfort and discomfort when dining at a restaurant which then affects customer satisfaction. Then the results of the study show that the atmosphere is one of the important factors that influence customer satisfaction during the pandemic (Zibarzani et al., 2022).

Based on research Chua et al. (2015), the quality of the physical environment as one of the factors forming the atmosphere, is an important driver of customer satisfaction. The findings show that the effect of physical environment quality on satisfaction is positive and significant in the context of a luxury hotel restaurant. Whereas (Zibarzani et al., 2022) confirmed the atmosphere to be an important factor affecting customer satisfaction in the context during the outbreak. Seeing that there is still little research that discusses the effect of restaurant atmosphere on customer satisfaction, researchers are interested in examining restaurant atmosphere variables on customer satisfaction. So the following hypothesis appears.

## **H2: Restaurant atmosphere has a positive effect on customer satisfaction**

### **Customer satisfaction**

Customers think satisfaction is something that is expected to be achieved through product purchases (Kim and Tang, 2020). Oliver (1980) conceptualize satisfaction as an evaluation of a customer's affective experience after a process of cognitive disconfirmation of expectations across prior expectations and perceived results of a product and its attributes. According to Liljander and Strandvik (1997) and Bigne et al. (2008), two components of customer satisfaction consist of cognitive and affective. The cognitive component includes a logical evaluation of the product purchased, while the emotional component includes emotions such as happiness and pleasure after receiving the product which then results in confirmation of expectations Yu and Dean (2001).

Customer satisfaction that is formed based on cognitive processes determines commitment, directly and indirectly raises intention to revisit (Han et al. 2011). Ali et al. (2016) said, after assessing the experience of a product as satisfactory, customers will make a decision to repurchase in the future. Han et al. (2011) explains that customer satisfaction directly or indirectly raises the intention to revisit. Repurchase describes the real action of customers in buying back products that have previously been consumed. Like research Setiawati and Murwanti (2006) which reveals the intensity of purchases will be higher with the achievement of customer satisfaction. If the context is a restaurant, repurchasing can be interpreted as visiting a restaurant again to get food after visiting it before.

When consumers are satisfied, the intention and desire to get it back is higher. However, when consumers do not find pleasure with the product or service, positive behavioral intentions and desires decrease (Han and Ryu, 2012). Research result Han and Hyun (2017) emphasized that customer satisfaction has a prominent role in determining behavioral intentions. The findings suggest that when customers are highly satisfied, they express an intention to repeatedly visit a restaurant in a hotel in the context of a luxury hotel restaurant.

In addition, the positive impact of customer satisfaction on behavioral intention emphasizes the importance of eliciting positive customer behavioral intention by ensuring customer satisfaction with the restaurant (Clemes et al., 2015). In accordance with

previous studies (Nazir et al., 2023; Park et al., 2019) which confirms that a satisfactory customer experience has a positive influence on revisit intention. The previous explanation has shown that in order to generate customer intention to revisit, it is necessary to ensure that the customer is satisfied with the service or product. Based on the theories above, the third hypothesis appears.

**H3: Customer satisfaction has a positive effect on the intention to revisit**

**Figure 1  
Research framework**

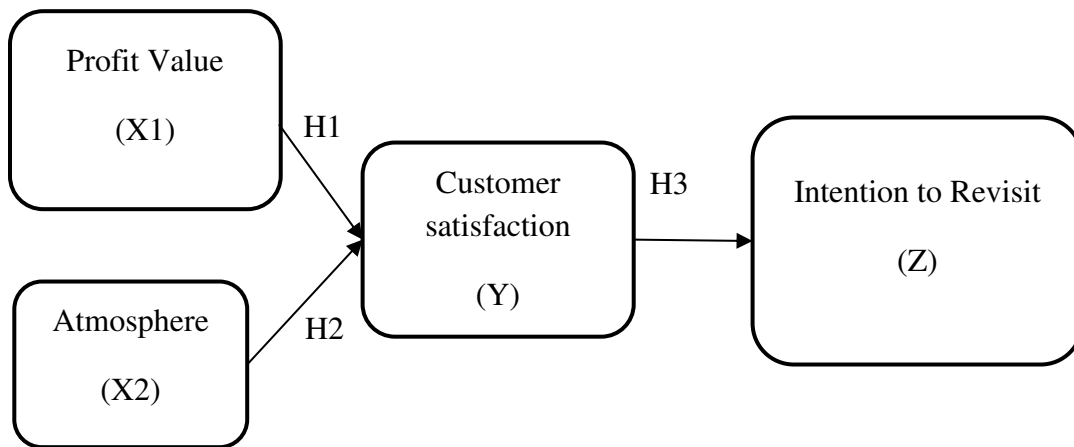

**RESEARCH METHOD**

**Data and sample collection procedures**

This research uses quantitative methods. The population used in this study are consumers who have visited restaurants. Then, the research sample was determined by the criteria of consumers who had visited the restaurant at least once in the last month.

The data used in this research is primary data. Data was collected by distributing questionnaires in the form of Google forms online via WhatsApp and Telegram. The questions asked in the questionnaire are modifications of the research questionnaire Konuk (2019) and Zibarzani et al. (2022). The questionnaire is structured into five parts of the Google form questionnaire, namely the first part contains the title and purpose of making the questionnaire, the respondent's personal data, and the number of visits to restaurants in the past month. The second part contains questions related to the value of profits. Part three contains questions related to the atmosphere of the restaurant. The fourth part contains questions related to customer satisfaction. The fifth section contains questions about revisit intentions. The choice of answers to the questions is made on a linear scale of one to five to make it easier for respondents to fill out the questionnaire according to their experience. A linear scale of one to five was chosen because it

represents the answers that do not agree to the answers that agree. Scale one is the lowest scale with information Strongly Disagree (STS), scale two has the statement Disagree (TS), scale three is the choice of Neutral (N), scale four is the second highest scale with the statement Agree (S), and scale five is the highest choice scale with the statement Strongly Agree (SS).

A total of 151 responses were collected with 83.4% of respondents being students and the age range between 21 to 30 years dominated by 79.5%. The number of respondents visiting restaurants one to three times was recorded at 66.2%, followed by 19.9% of respondents visiting restaurants four to six times in the past month, and the remaining 13.9% visiting restaurants more than six times in the past month. All questionnaire answers were accepted as valid answers to be examined later.

### **Research instrument**

Modified gain value instrument from research Konuk (2019) and Zibarzani et al. (2022) includes the fairness of food prices and price compatibility with food. Atmosphere is assessed by four modification items from Zibarzani et al. (2022), including employee appearance, interior design and layout, and temperature. Then customer satisfaction and revisit intention were assessed by modifying items from Konuk (2019).

## **DATA ANALYSIS AND DISCUSSIONS**

### **Validity and Reliability**

The analysis model was chosen based on the type of quantitative research with primary data. Modify from research (Konuk, 2019) and (Zibarzani et al., 2022), research data were analyzed using Partial Least Square Structural Equation Modeling (PLS-SEM) with the help of SmartPLS 3 software. Then to test the mediating role of customer satisfaction was carried out based on the structural model. PLS-SEM analysis is carried out with several research steps, namely using the outer model analysis. There are three main tests to check validity and reliability, namely convergent validity and discriminant validity, and internal consistency. Convergent validity tests survey items by considering their outer loading with outer loading values  $> 0.7$  and AVE  $> 0.5$ . The next step is to check internal consistency based on Cronbach's Alpha (CA) and Composite Reliability (CR) tests with values that must be  $> 0.7$ . The Path Coefficient (PC) test was carried out using the bootstrap technique with the t test parameter to take into account the relationship. The coefficient value of each path must meet  $> 2$  and an alpha of 5% (Hair et al., 2017).

### **Figure 2**

**OuterModel**

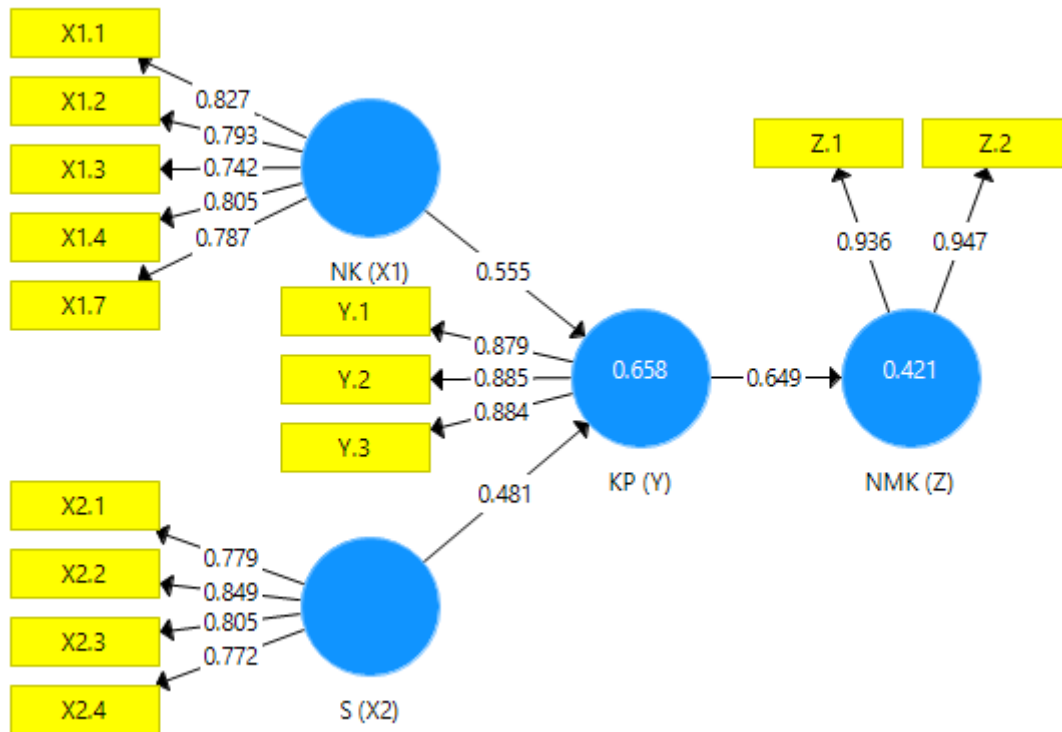

**Table 1**

**Outer Loading, Convergent Validity and Reliability**

Variables and Indicators	Outer Loading	Cronbach's Alpha	rho_A	CR	AVE
Profit value		0.851	0.858	0.893	0.626
NK. 1	0.827				
NK. 2	0.793				
NK. 3	0.742				
NK. 4	0.805				
NK. 7	0.787				
Atmosphere		0.815	0.817	0.878	0.643
S.1	0.779				
S.2	0.849				
S.3	0.805				
S.4	0.772				

Customer satisfaction		0.858	0.859	0914	0.779
KP. 1	0879				
KP. 2	0.885				
KP. 3	0.884				
Intention to revisit		0.872	0.878	0.940	0887
NMK. 1	0936				
NMK. 2	0947				

**Table 2  
Fornell-Lacker**

	KP (Y)	NK (X1)	NMK (Z)	S(X2)
KP (Y)	0.883			
NK (X1)	0.661	0.791		
NMK (Z)	0.649	0.440	0.942	
S(X2)	0.604	0.221	0.406	0.802

Table 1 and Table 2 show that all variables and indicators have fulfilled the validity and reliability test requirements. Previously there were three variables with outer loading values < 0.7, namely NK 5, NK 6, and NMK 3 so they were deleted leaving the other variables presented in Table 1. All of the remaining variable indicators already have outer loading values > 0.7, which means the variable meets the requirements of convergent validity. Then the NK variable appears to have an AVE value of 0.626, S variable of 0.643, KP of 0.779, and NMK of 0.887. Each of the AVE values of the research variables shown in Table 1 fulfills the requirements > 0.5 so that all variables are valid in the discriminant validity test. Then the value of Cronbach's Alpha and Composite Reliability have met the requirements value > 0,7 which means the data is valid and acceptable (Hair et al., 2017).

**Analysis**

**Table 3  
Mean, STDEV, T-Values, P-Values**

hypothesis	Original Sample	Sample Means	Standard Deviations	T Statistics	P Values
<b>Hypothesis 1.NK -&gt; KP</b>	0.555	0.545	0.059	9,382	0.000

<b>Hypothesis 2.S</b> -> KP	0.481	0.485	0.058	8,245	0.000
<b>Hypothesis 3.KP</b> -> NMK	0.649	0.662	0.080	8,100	0.000

The data presented show that Hypothesis 1 suggests a positive effect of NK on KP is confirmed as significant positive with p values  $0.000 < 0.05$  and t-statistics  $9,382 > 1.96$ . In line with previous research (Uzir et al., 2021; El-Adly, 2019; Konuk, 2019; Chicu et al., 2019; Nami, 2017; García-Fernández et al., 2018; Ryu et al., 2008) which confirms the significant effect of profit value on consumer satisfaction. The relationship between S and KP with p values  $0.000 < 0.05$  and t-statistics  $8,245 > 1.96$  was stated to be significantly positive, so that Hypothesis 2 was supported. The same opinion was also expressed Chua et al. (2015), the quality of the physical environment on satisfaction is positive and significant in the context of a luxury hotel restaurant. Study (Zibarzani et al., 2022) also confirmed atmosphere affects customer satisfaction in the context during the outbreak. Hypothesis 3 confirms the positive and significant relationship between KP and NMK with the results presented in the table p values  $0.000 < 0.05$  and t-statistics  $8.100 > 1.96$ .

**Table 4**  
**Indirect Effects**

	<b>Original Sample</b>	<b>Sample Means</b>	<b>Standard Deviations</b>	<b>T Statistics</b>	<b>P Values</b>
NK -> KP -> NMK	0.360	0.359	0.050	7.168	0.000
S -> KP -> NMK	0.312	0.322	0.062	5033	0.000

Then in Table 4 it can be observed the mediating role of Trust in the hypothesis. After entering KP into the relationship between NK and NMK, it produces an indirect effect of KP with p values  $0.000 < 0.05$  and t-statistics  $7,168 > 1.96$ , so that the KP mediating relationship between NK and NMK is confirmed. This research confirms that Consumer Satisfaction acts as a partial intervention construct between Perceived Value and Revisit Intention (Konuk, 2019). The relationship between S and NMK was also confirmed to be mediated by KP with p values  $0.000 < 0.05$  and t-statistics  $5,033 > 1.96$ .

**CONCLUSIONS AND SUGGESTIONS**

The findings show that the value of the benefits that customers feel when consuming food and the atmosphere of a restaurant can influence customer satisfaction. Then customer satisfaction becomes one of the determinants of the emergence of intention to revisit. When customers are satisfied with the value they receive from the food

and the atmosphere of the restaurant makes them comfortable visiting the restaurant, the intention to revisit is even greater. In line with several other studies. Given the importance of the perceived profit value for customers, restaurant owners need to pay attention to the factors that support the formation of profit value, such as providing prices that are not too high and in accordance with the quality of the food provided, so that customers will not feel disadvantaged after consuming the food. Besides that, the price and quality of food must also be considered in accordance with the restaurant's target market. Furthermore, the atmosphere of the restaurant which is also an important factor in customer satisfaction needs to be considered. The atmosphere will be very influential for customers who eat on the spot. Cool room temperature, layout that facilitates movement, neat and attractive interior arrangement, clean and tidy appearance of restaurant employees make customers feel at home when visiting the restaurant.

These findings show the important role of customer satisfaction in determining customer intention to revisit. In conclusion, highly satisfied customers after visiting a restaurant have a high intention to revisit (Konuk, 2019).

This research can be a reference and reading for future research that examines the same topic. However, customer satisfaction and intention to revisit are not only measured through the profit value and atmosphere of the restaurant. There are many other variables that can affect customer satisfaction that can be studied in the future. So that more and more research and knowledge about the factors that influence customer satisfaction and intention to revisit.

## REFERENCES

- Ali, Faizan, Kisang Ryu, and Kashif Hussain. 2016. "Influence of Experiences on Memories, Satisfaction and Behavioral Intentions: A Study of Creative Tourism." *Journal of Travel and Tourism Marketing* 33 (1): 85–100. <https://doi.org/10.1080/10548408.2015.1038418>.
- Assaker, Guy, Vincenzo Esposito Vinzi, and Peter O'Connor. 2011. "Examining the Effect of Novelty Seeking, Satisfaction, and Destination Image on Tourists' Return Pattern: A Two Factor, Non-Linear Latent Growth Model." *Tourism Management* 32(4): 890–901. <https://doi.org/10.1016/j.tourman.2010.08.004>.
- Bigné, J. Enrique, Anna S. Mattila, and Luisa Andreu. 2008. "The Impact of Experiential Consumption Cognitions and Emotions on Behavioral Intentions." *Journal of Services Marketing* 22(4): 303–15. <https://doi.org/10.1108/08876040810881704>.
- Chicu, Dorina, Maria del Mar Pàmies, Gerard Ryan, and Christine Cross. 2019. "Exploring the Influence of the Human Factor on Customer Satisfaction in Call Centres." *BRQ Business Research Quarterly* 22(2): 83–95. <https://doi.org/10.1016/j.brq.2018.08.004>.
- Chua, Bee Lia, Sanghyeop Lee, Ben Goh, and Heesup Han. 2015. "Impacts of Cruise

- Service Quality and Price on Vacationers' Cruise Experience: Moderating Role of Price Sensitivity." *International Journal of Hospitality Management* 44: 131–45. <https://doi.org/10.1016/j.ijhm.2014.10.012>.
- El-Adly, Mohammed Ismail. 2019. "Modeling the Relationship between Hotel Perceived Value, Customer Satisfaction, and Customer Loyalty." *Journal of Retailing and Consumer Services* 50 (xxxx): 322–32. <https://doi.org/10.1016/j.jretconser.2018.07.007>.
- Feng, Taiwen, Dan Wang, Alan Lawton, and Ben Nanfeng Luo. 2019. "Customer Orientation and Firm Performance: The Joint Moderating Effects of Ethical Leadership and Competitive Intensity." *Journal of Business Research* 100 (February 2018): 111–21. <https://doi.org/10.1016/j.jbusres.2019.03.021>.
- García-Fernández, Jerónimo, Pablo Gálvez-Ruíz, Jesús Fernández-Gavira, Luisa Vélez-Colón, Brenda Pitts, and Ainara Bernal-García. 2018. "The Effects of Service Convenience and Perceived Quality on Perceived Value, Satisfaction and Loyalty in Low-Cost Fitness Centers." *Sports Management Review* 21 (3): 250–62. <https://doi.org/10.1016/j.smr.2017.07.003>.
- Hair, Joseph F., G. Tomas M. Hult, Christian M. Ringle, Marko Sarstedt, and Kai Oliver Thiele. 2017. "Mirror, Mirror on the Wall: A Comparative Evaluation of Composite-Based Structural Equation Modeling Methods." *Journal of the Academy of Marketing Science* 45 (5): 616–32. <https://doi.org/10.1007/s11747-017-0517-x>.
- Han, Heesup, Li Tzang Jane Hsu, Jin Soo Lee, and Chwen Sheu. 2011. "Are Lodging Customers Ready to Go Green? An Examination of Attitudes, Demographics, and Eco-Friendly Intentions." *International Journal of Hospitality Management* 30 (2): 345–55. <https://doi.org/10.1016/j.ijhm.2010.07.008>.
- Han, Heesup, and Sunghyup Sean Hyun. 2017. "Impact of Hotel-Restaurant Image and Quality of Physical-Environment, Service, and Food on Satisfaction and Intention." *International Journal of Hospitality Management* 63: 82–92. <https://doi.org/10.1016/j.ijhm.2017.03.006>.
- Han, Heesup, and Kisang Ryu. 2012. "The Theory of Repurchase Decision-Making (TRD): Identifying the Critical Factors in the Post-Purchase Decision-Making Process." *International Journal of Hospitality Management* 31(3): 786–97. <https://doi.org/10.1016/j.ijhm.2011.09.015>.
- Kim, Eojina, and Liang (Rebecca) Tang. 2020. "The Role of Customer Behavior in Forming Perceived Value at Restaurants: A Multidimensional Approach." *International Journal of Hospitality Management* 87 (February): 102511. <https://doi.org/10.1016/j.ijhm.2020.102511>.
- Konuk, Faruk Anil. 2019. "The Influence of Perceived Food Quality, Price Fairness, Perceived Value and Satisfaction on Customers' Revisit and Word-of-Mouth Intentions towards Organic Food Restaurants." *Journal of Retailing and Consumer*

- Services 50: 103–10. <https://doi.org/10.1016/j.jretconser.2019.05.005>.
- Laukkanen, Minttu, and Nina Tura. 2022. “Sustainable Value Propositions and Customer Perceived Value: Clothing Library Case.” *Journal of Cleaner Production* 378 (September): 134321. <https://doi.org/10.1016/j.jclepro.2022.134321>.
- Liljander, Veronica, and Tore Strandvik. 1993. “Estimating Zones of Tolerance in Perceived Service Quality and Perceived Service Value.” *International Journal of Service Industry Management* 4 (2): 6–28. <https://doi.org/10.1108/09564239310037909>.
- . 1997. “Emotions in Service.” *International Journal of Service Industry Management* 8 (2): 148–69.
- Michael Daniel Clemes, Zurinawati Mohi, Xuedong Li, Baiding Hu. 2015. *Asia Pacific Journal of Marketing and Logistics*. Asia Pacific Journal of Marketing and Logistics. Vol. 27.
- Namin, Aidin. 2017. “Revisiting Customers' Perception of Service Quality in Fast Food Restaurants.” *Journal of Retailing and Consumer Services* 34 (September 2016): 70–81. <https://doi.org/10.1016/j.jretconser.2016.09.008>.
- Nazir, Sajjad, Sahar Khadim, Muhammad Ali Asadullah, and Nausheen Syed. 2023. “Exploring the Influence of Artificial Intelligence Technology on Consumer Repurchase Intention: The Mediation and Moderation Approach.” *Technology in Society* 72. <https://doi.org/10.1016/j.techsoc.2022.102190>.
- Park, Jeong Yeol, Diego Bufquin, and Robin M. Back. 2019. “When Do They Become Satisfied? An Examination of the Relationships among Winery Tourists' Satisfaction, Repeat Visits and Revisit Intentions.” *Journal of Destination Marketing and Management* 11 (April): 231–39. <https://doi.org/10.1016/j.jdmm.2018.04.004>.
- Peng, Lifang, Weiguo Zhang, Xiaorong Wang, and Shuyi Liang. 2019. “Moderating Effects of Time Pressure on the Relationship between Perceived Value and Purchase Intention in Social E-Commerce Sales Promotion: Considering the Impact of Product Involvement.” *Information and Management* 56 (2): 317–28. <https://doi.org/10.1016/j.im.2018.11.007>.
- RL, Oliver. 1980. “A Cognitive Model of the Antecedents and Consequences of Satisfaction Decisions.” *Journal of Marketing Research* 17(4) (November): 460–69.
- Ryu, Kisang, and Heesup Han. 2011. “New or Repeat Customers: How Does the Physical Environment Influence Their Restaurant Experience?” *International Journal of Hospitality Management* 30 (3): 599–611. <https://doi.org/10.1016/j.ijhm.2010.11.004>.
- Ryu, Kisang, Heesup Han, and Tae Hee Kim. 2008. “The Relationships among Overall Quick-Casual Restaurant Image, Perceived Value, Customer Satisfaction, and

- Behavioral Intentions." *International Journal of Hospitality Management* 27 (3): 459–69. <https://doi.org/10.1016/j.ijhm.2007.11.001>.
- Setiawati, Erma, and Sri Murwanti. 2006. "The Influence of Service Quality and Customers in Forming Consumer Purchase Intentions." *Benefits* 10 (1): 79–92.
- Uzir, Md Uzir Hossain, Hussam Al Halbusi, Ramayah Thurasamy, Rodney Lim Thiam Hock, Musheer A. Aljaberi, Najmul Hasan, and Mahmud Hamid. 2021. "The Effects of Service Quality, Perceived Value and Trust in Home Delivery Service Personnel on Customer Satisfaction: Evidence from a Developing Country." *Journal of Retailing and Consumer Services* 63 (April). <https://doi.org/10.1016/j.jretconser.2021.102721>.
- Uzir, Md Uzir Hossain, Ishraq Jerin, Hussam Al Halbusi, Abu Bakar Abdul Hamid, and Ahmad Shaharudin Abdul Latiff. 2020. "Does Quality Stimulate Customer Satisfaction Where Perceived Value Mediates and the Usage of Social Media Moderates?" *Heliyon* 6 (12). <https://doi.org/10.1016/j.heliyon.2020.e05710>.
- Yu, Yi Ting, and Alison Dean. 2001. "The Contribution of Emotional Satisfaction to Consumer Loyalty." *International Journal of Service Industry Management* 12 (3): 234–50. <https://doi.org/10.1108/09564230110393239>.
- Zeithaml, Valarie A. 1988. "Consumer Perceptions of Price, Quality, and Value: A Means-End Model and Synthesis of Evidence Evidence." *Blood* 62 (5): 1047–54. <https://doi.org/10.1182/blood.v62.5.1047.1047>.
- Zibarzani, Masoumeh, Rabab Ali Abumalloh, Mehrbakhsh Nilashi, Sarminah Samad, OA Alghamdi, Fatima Khan Nayer, Muhammed Yousoof Ismail, Saidatulakmal Mohd, and Noor Adelyna Mohammed Akib. 2022. "Customer Satisfaction with Restaurant Service Quality during COVID-19 Outbreak: A Two-Stage Methodology." *Technology in Society* 70 (March): 101977. <https://doi.org/10.1016/j.techsoc.2022.101977>.